

REPLACING THE WATER FILTER

It is recommended that you replace the filter when the water filter indicator reaches **0** or the water dispenser or icemaker noticeably decreases production.

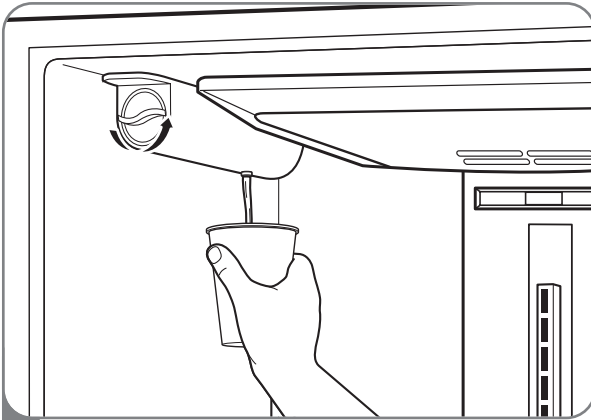

- 1 Rotate the knob of the old cartridge counterclockwise. When the cartridge is released, you will feel it click out of place.

NOTE: Replacing the filter causes a small amount of water (around 1 oz. or 25 cc) to drain. Place a cup under the filter hole to contain it.

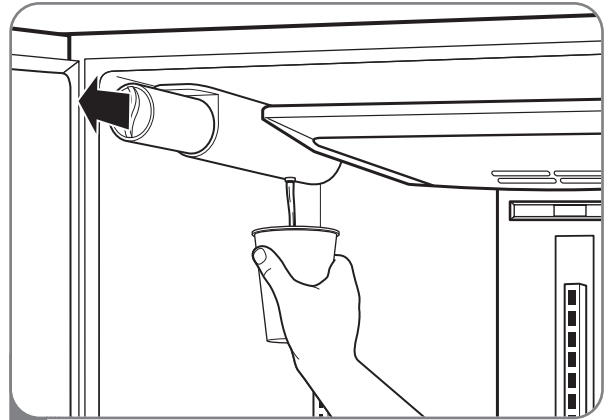

- 2 Remove the old cartridge. Take the new cartridge out of its packaging, and remove the protective cover from the o-rings. Hold the cartridge handle in its vertical position, and firmly push the new filter cartridge into place until it stops.

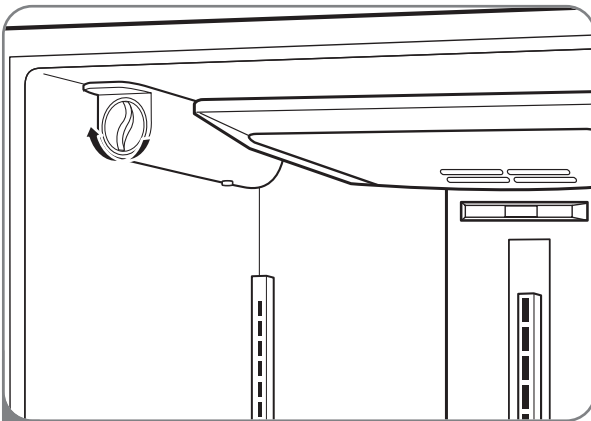

- 1 Use the handle to twist the cartridge clockwise about one turn, until the handle is in a horizontal position. You will feel the filter click into place.

NOTE: If the filter will not turn from side to side, it isn't fully inserted.

After replacing the filter, flush 2.5 gallons through filter before use (flush for approximately 5 minutes). Check the filter for leaks.



When the water filter indicator displays the message **0 Filter Month, Hold 3 Seconds**, reset the water filter status display and indicator light by pressing and holding the LIGHT/FILTER button for more than 3 seconds.

To purchase replacement water filter cartridges, visit your local appliance dealer or parts distributor. You can also call 1-877-714-7486.

The replacement water filter cartridge's part number is **5231JA2006A**.