



EV9100-51

CB20-124E Water Filter

High flow, high capacity carbon filter for chlorine and chloramine reduction



CB20-124E System: EV9100-51

124 Replacement Cartridge Kit:
EV9105-02

Kit contains: (1) CC1E replacement cartridge

BENEFITS

- Improves the taste and consistency of beverages and ice by reducing chloramine, chlorine and other off-tastes and odors
- CC1E extended service cartridge contains radial flow granular activated carbon (GAC)
- High pressure housing includes head with pressure relief valve, mounting bracket and bowl
- Integral outlet pressure gauge monitors operation
- Easily plumbs to existing filtration systems to add chloramine reduction capability
- Complete modular package lets you expand capacity as needed

INSTALLATION TIPS

- Choose a mounting location which is suitable to support the full weight of the system when operating (30 lbs.)
- 3/4" FNPT inlet and outlet connection
- Install on cold water lines only
- Do not install where unit is exposed to direct sunlight
- Allow a minimum of 4" clearance under the filter to facilitate cartridge change
- Do not braze/solder fittings into head
- Never use a saddle valve for connection

OPERATION TIPS

- Change cartridge on a regular 6 month preventative maintenance program
- Change cartridge when capacity is reached (15,000 gallons) or when flow becomes too slow
- Change cartridge when the difference between the inlet pressure and the system outlet gauge is greater than or equal to 20 psi
- Service flow rate must not exceed 5.0 gpm
- Always flush the filter cartridge to drain for fifteen minutes at time of installation and cartridge change

APPLICATION/SIZING

- For high flow, high volume foodservice applications requiring chloramine reduction
- Rated Capacity: 15,000 gallons (56,775L)
- Up to 5 gpm (19 Lpm) flow rate
- For coffee and ice applications, add scale reduction feeder at outlet of system. Part no. EV9798-45

CB20-124E Water Filter

SPECIFICATIONS

Overall Dimensions:
25.875"H x 7.25"W x 8.5"D

Inlet connection:
3/4" FNPT

Outlet connection:
3/4" FNPT

Service Flow Rate:
Maximum 5.0 gpm (19 Lpm)

Rated Capacity: 15,000 gallons (56,775L)

Pressure Requirements:
20 - 100 psi (1.4 - 6.9 bar), non-shock

Temperature:
35 - 100°F (2-38°C)

No electrical connection required

Shipping Weight: 22 lbs.

The contaminants or other substances removed or reduced by this drinking water system are not necessarily in your water. Do not use with water that is microbiologically unsafe or of unknown quality without adequate disinfection before or after the system. Systems certified for cyst reduction may be used with disinfected water that may contain filterable cysts.

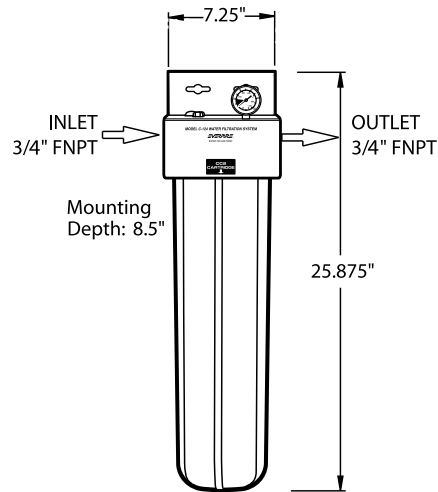

WARRANTY

Everpure water treatment systems (excluding replaceable elements) are covered by a limited warranty against defects in material and workmanship for a period of five years after date of purchase. Everpure replaceable elements (filter cartridges and water treatment cartridges) are covered by a limited warranty against defects in material and workmanship for a period of one year after date of purchase. See printed warranty for details. Everpure will provide a copy of the warranty upon request.

EVERPURE®

Worldwide Headquarters:
EVERPURE, LLC
1040 Muirfield Drive
Hanover Park, Illinois 60133
Toll Free (800) 323-7873
Tel (630) 307-3000
Fax (630) 307-3030
<http://www.everpure.com>

In Europe:
Pentair Water Belgium B.V./B.A.
Industriepark Wolfstee
Toekomstlaan 30
B- 2200 Herentals
BELGIUM
TEL: +32.(0).14.283.500
FAX: +32.(0).14.283.505

In Japan:
Hashimoto MN Bldg. 7F
3-25-1 Hashimoto Sagamihara-Shi
Kanagawa 229-1103
JAPAN
TEL: 81.(0)42.775.3011
FAX: 81.(0)42.775.3015

Everpure
1040 Muirfield Drive
Hanover Park, IL 60133