



Experts in water.

DAVEY

APPLICATIONS

Automatic pressure system for:-

- Household, domestic and light industrial water supply
- Farming and agricultural water systems
- Irrigation and turf watering systems
- Automatic general water transfer
- Mains water pressure boosting

WHY CHOOSE THE

Davey Speedman Compact with HM pump constant pressure system?

Variable drive system provides lower running costs due to matching motor speed to hydraulic demand, and at the same time providing:

- Lower operating noise
- Smoother water flow from outlets
- Less pressure variation when other outlets are opened
- Under and over voltage protection
- Loss of prime protection
- Auto-retry in the event of fault
- Motor overload protection

Horizontal multistage centrifugal pump with all hydraulic parts in stainless steel

- Corrosion and wear resistant
- Low noise output

Axial suction and vertical discharge

- Compact design
- Easy to install

Stainless steel impellers with high efficiency impeller profile and thick self-centring impeller neck rings:-

- High efficiency
- Reduced power consumption
- Low noise output

Impellers mounted directly on extended motor shaft

- Maximised performance per stage
- High efficiency
- Long motor and pump life
- Increased wear resistance

Pump casing assembly attached to motor bracket at 8 points with oring seal

- Complete stainless casing
- Better sealing
- Longer service life

cont. overleaf...



Speedman Compact with HM pump Variable Speed Constant Pressure System

Model Numbers:

SMCHM60-10 & SMCHM90-11

Constant pressure, variable speed water pressure systems with all stainless steel pump and baseplate, in two models capable of flows up to 130 lpm and heads to 66m. Maximum constant pressure when boosting incoming supply is 750kPa (76m).



Davey built, totally enclosed fan cooled (TEFC) three phase electric motor

- Sealed and greased for life motor bearings
- Over sized drive bearing
- Longer life
- Easy service
- Economical and quiet running

System designed for 220-240V 50Hz single phase supply and includes 1.7m long power lead and Australian 3 pin plug

- Quick and easy to install

Variable speed drive control mounted separate to pump and with waterflow cooling for easier service and better motor cooling.

Pump able to be re-mounted on base with suction facing left for versatility.

Variable speed drive control has simple menu and easy to read display for simpler installation and use.

Discharge checkvalve built into variable speed drive controller for easier installation and protection from system backpressure.

MATERIALS OF CONSTRUCTION	
Part	Material
Casing	304 stainless steel
Impellers	304 stainless steel
Stages (diffusers)	304 stainless steel
Pump shaft	316L stainless steel
Stage centring device	304 stainless steel
Mechanical seal	Carbon / ceramic
Orings	EPDM
Plugs	316L stainless steel
Motor shell and lantern bracket	Aluminium with baked polyester powder coat finish
Motor feet	Xenoy®
Fan cowl / rear foot	Polypropylene
System base and controller mounting bracket and fasteners	304 stainless steel

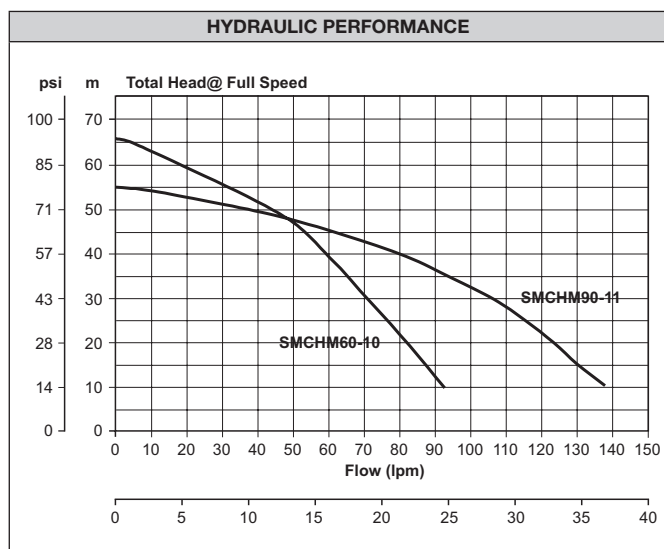

Note: 60Hz performance may vary slightly from above data.

OPERATING LIMITS	
Capacities up to	130 lpm (7.8m³/hr)
Pressure heads up to	66m
Maximum constant operating pressure (subject to incoming pressure to be boosted)	750kPa
Maximum ambient temperature	40° C
Maximum water temperature	40° C
Frequency	50Hz*

*For 60Hz operation contact Davey

Suitable fluids

Clean potable water of neutral ph containing no solids or abrasives.

ELECTRICAL DATA		
	SMCHM60-10	SMCHM90-11
Speed – maximum @ 50Hz	PC15 & PC22	
Supply voltage	220V ± 10%	
Pump motor voltage	Single	
Supply frequency	50 / 60	
Insulation class	65	
Enclosure class	IP55	
Pump motor	IP65	
Control panel	IP65	
Max. input power (P ₁) @ 50Hz full speed	1.2kW	1.4kW
Max. Amps @ 50Hz full speed	8.0	9.1

SMCHM60-10					SMCHM90-11				
Flow (lpm)	200kPa*		400kPa*		Flow (lpm)	200kPa*		400kPa*	
	I (A)	P1 (kW)	I (A)	P1 (kW)		I (A)	P1 (kW)	I (A)	P1 (kW)
20	2.73	0.37	4.5	0.65	20	2.80	0.38	4.7	0.66
50	4.64	0.66	7.0	1.04	50	3.86	0.54	6.5	0.96
55	5.05	0.73	7.5	1.10	70	4.90	0.71	7.8	1.20
60	5.50	0.80	8.0	1.20	90	6.30	0.93		
70	6.67	0.98			100	8.00	1.22		
80	7.80	1.20							

*Amperage within constant pressure range based on zero incoming pressure

DIMENSIONS (mm)			
Type	Inlet	Outlet	Weight (kg)
SMCHM60-10	1¼" F	1¼" F	21
SMCHM90-11	1¼" F	1¼" F	21

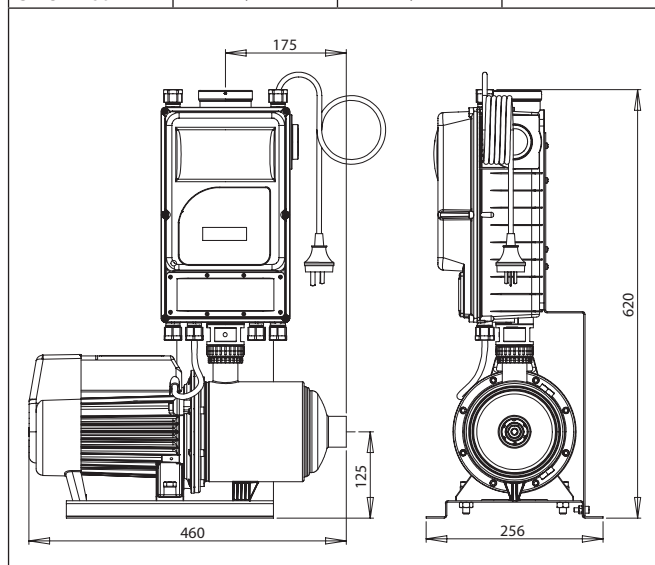

davey.com.au | daveynz.co.nz

This literature is not a complete guide to product usage. Further information is available from your Davey Dealer, Davey Support Centre and from the relevant product Installation and Operating Instructions. Must be read in conjunction with the relevant product Installation and Operating Instructions and all applicable statutory requirements. Product specifications may change without notice. TM Davey is a trademark of Davey Water Products Pty Ltd. © Davey Water Products Pty Ltd 2014.