



EV9797-21

Kleensteam II Single System

Everpure's second generation of total water treatment system for steam applications



Kleensteam II Single System: EV9797-21

7CB5 Replacement Cartridge: EV9618-11

SS-10 Cartridge: EV9799-02

BENEFITS

A total system delivering high quality filtered water with scale inhibition and deliming capabilities

New dual cartridge design provides enhanced performance for low or high flow capacity steamers and flexibility for expanding to meet future needs

Fine filters incoming water to improve the performance, maximize energy efficiency and increase the life of steam equipment

Reduces chlorine-induced corrosion

System is simple to install, operate and maintain

Easy deliming with ScaleKleen, which is fed into the boiler through the SR-X bowl without use of hazardous chemicals or special piping

Long lasting SS-10 cartridge is more effective in higher alkalinity/hardness/TDS/temperature installations

Sophisticated Hydroblend compound prevents limescale formation in high temperature steam applications

INSTALLATION TIPS

Choose a mounting location suitable to support the full weight of the system when operating

Use minimum 1/2" inlet water line (3/4" preferred)

Connect the system to the boiler feed water line only! Do not connect to the condenser water line!

Install vertically with cartridges hanging down

Allow 2-1/2" clearance below the cartridge for easy cartridge replacement

Flush cartridges by running water through filter for five minutes at full flow

OPERATION TIPS

Change 7CB5 cartridge on a regular 6 month preventative maintenance program, when capacity is reached or when pressure falls below 10 psi

Change SS-10 cartridge before Hydroblend™ compound is completely used up

Service flow rate must not exceed 2.5 gpm for single cartridge systems or 5.0 for dual cartridge systems

Always flush the filter cartridge at time of installation and cartridge change

Use for periodic deliming as needed by installing the dip tube assembly in place of the SS-10 and dissolving Scale Kleen in SR-X housing. Full deliming instructions are provided with the system

APPLICATION/SIZING

For commercial steam applications

For use with foodservice steamer and combi-oven applications

The Kleensteam II Single System is shipped with one 7CB5 cartridge (for first filter head) and one filter head plug installed in the second filter head. Capacity is expandable by adding a second 7CB5 cartridge.

Kleensteam II Single System

SPECIFICATIONS

Overall Dimensions:
25.5"H x 20.5"W x 7"D

Inlet connection: 3/4" FNPT

Outlet connection: 3/4" FNPT

Service Flow Rate:
Maximum 2.5 gpm (9.5 Lpm) - single
cartridge

Pressure Requirements:
10 - 125 psi (0.7 - 8.6 bar), non-shock

Maximum water temperature at inlet:
100°F (38°C)

Alkalinity range:
2 to 12 grains per gallon

No electrical connection required

Shipping Weight: 26 lbs.

Operating Weight: 32 lbs.

The contaminants or other substances removed or reduced by this drinking water system are not necessarily in your water. Do not use with water that is microbiologically unsafe or of unknown quality without adequate disinfection before or after the system. Systems certified for cyst reduction may be used with disinfected water that may contain filterable cysts.

ScaleStick is NSF Certified under NSF/ANSI Standard 42 for materials

KleenSteam II - Single Cartridge

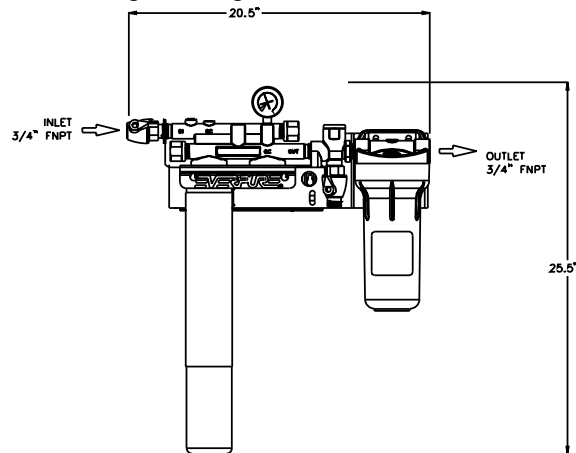

WARRANTY

Everpure water treatment systems (excluding replaceable elements) are covered by a limited warranty against defects in material and workmanship for a period of five years after date of purchase. Everpure replaceable elements (filter cartridges and water treatment cartridges) are covered by a limited warranty against defects in material and workmanship for a period of one year after date of purchase. See printed warranty for details. Everpure will provide a copy of the warranty upon request.

EVERPURE

EVERPURE, LLC
1040 Muirfield Drive
Hanover Park, Illinois 60133
Toll Free (800) 323-7873
Tel (630) 307-3000
Fax (630) 307-3030
<http://www.everpure.com>

In Europe:
N.V. EVERPURE (EUROPE) S.A.
INDUSTRIEPARK WOLFSTEE
TOEKOMSTLAAN 30
B-2200 HERENTALS
BELGIUM
TEL 32 -14-283500
FAX 32-14-283505

In Japan:
EVERPURE JAPAN LLC
HASHIMOTO MN BLDG. 7F
3-25-1 HASHIMOTO SAGAMIHARA-SHI
KANAGAWA 229-1103
JAPAN
TEL 81-(0)42-775-3011
FAX 81-(0)42-775-3015

Everpure, LLC
1040 Muirfield Drive
Hanover Park, IL 60133
Ph: 630-307-3000 Fax: 630-307-3030