



EV9272-41

# QC7I Single Head

Filter head exclusively for Everpure replacement cartridges



QC7I Single Head: EV9272-41

## BENEFITS

- Commercial quality filter head is designed exclusively to fit Everpure filter cartridges
- Includes built-in water shut off valve
- Includes mounting bracket and screws
- Built-in water pressure gauge helps monitor proper flow
- All wetted parts have passed NSF extraction tests
- Engineered for durability, strength and longevity
- Will not corrode

## INSTALLATION TIPS

- Mounts directly onto flat surface
- Install vertically so cartridge hangs down
- Allow 2-1/2" clearance below the cartridge for easy cartridge replacement
- Flush filter by running water through filter according to cartridge instructions

## OPERATION TIPS

- Change cartridges on a regular 6 month preventative maintenance program
- Change cartridges when capacity is reached or when pressure decreases
- Always flush the filter cartridge at time of installation and cartridge change

## APPLICATION/SIZING

- For foodservice applications
- Capacity: varies according to filter cartridge used

# QC7I Single Head

## SPECIFICATIONS

Overall Dimensions: 7.59"H x 8.04"W x 5.25"D

Inlet connection: 3/8"

Outlet connection: 3/8"

No electrical connection required

Shipping Weight: 1 lbs.

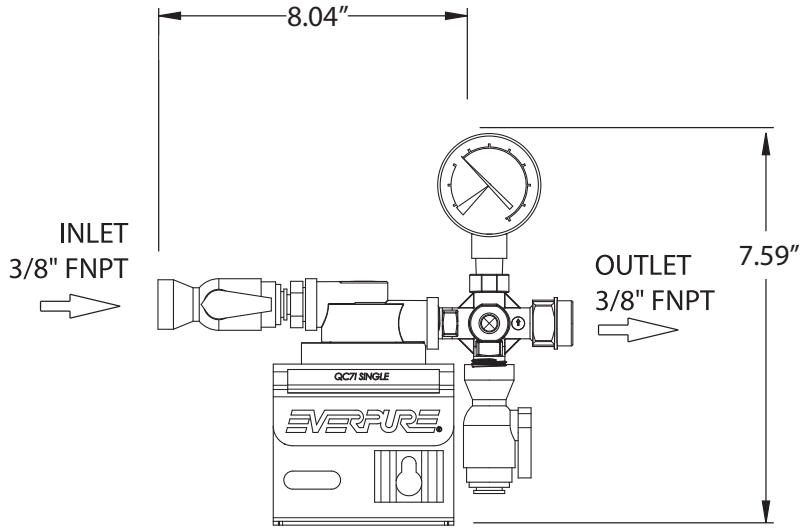

## WARRANTY

Everpure water treatment systems (excluding replaceable elements) are covered by a limited warranty against defects in material and workmanship for a period of five years after date of purchase. Everpure replaceable elements (filter cartridges and water treatment cartridges) are covered by a limited warranty against defects in material and workmanship for a period of one year after date of purchase. See printed warranty for details. Everpure will provide a copy of the warranty upon request.

# EVERPURE®

EVERPURE, LLC  
1040 Muirfield Drive  
Hanover Park, Illinois 60133  
Toll Free (800) 323-7873  
Tel. (630) 307-3000  
Fax (630) 307-3030  
<http://www.everpure.com>

*In Europe:*  
EVERPURE EUROPE bvba  
INDUSTRIEPARK WOLFSTEE  
TOEKOMSTLAAN 30  
B-2200 HERENTALS  
BELGIUM  
TEL 32-14-283500  
FAX 32-14-283505

*In Japan:*  
EVERPURE JAPAN LLC  
HASHIMOTO MN BLDG. 7F  
3-25-1 HASHIMOTO SAGAMIHARA-SHI  
KANAGAWA 229-1103  
JAPAN  
TEL 81-(0)42-775-3011  
FAX 81-(0)42-775-3015