

SPECIFICATIONS:

MODEL NUMBER: 8005-733-255

PUMP DESIGN: Positive Displacement 3 Chamber Diaphragm Pump

CHECK VALVE: (1-Way Operation) Prevents Reverse Flow

CAM: 3.0 Degree

MOTOR: Permanent Magnet, P/N 11-150-00, Thermally Protected

VOLTAGE: 115 VAC Nominal

PRESSURE SWITCH: Adjustable Shut-Off (Range 40-60 PSI)

Factory Set @ 60 PSI, Turn On 45 PSI ± 5 PSI

LIQUID TEMPERATURE: 170 Degrees Fahrenheit (77 Degrees Centigrade) Max.

PRIME: Self-Priming Up To 11 Ft. Vertical,
Max. Inlet Pressure 30 PSI (2.1 Bar)

PORTS: 3/8"-18 NPT Female

MATERIAL OF CONSTRUCTION:

PLASTICS- Polypropylene

VALVES- EPDM

DIAPHRAGM- Santoprene

FASTENERS- Zinc Plated Steel

NET WEIGHT: 3.9 Lbs (1.77 Kg)

DUTY CYCLE: Intermittent (See Temperature Rise Chart)

APPROVALS: U.L. & C.S.A. Recognized Component, N.S.F. Listed

TYPICAL APPLICATIONS: Water Delivery

BYPASS: 45 PSI

DIMENSIONS:

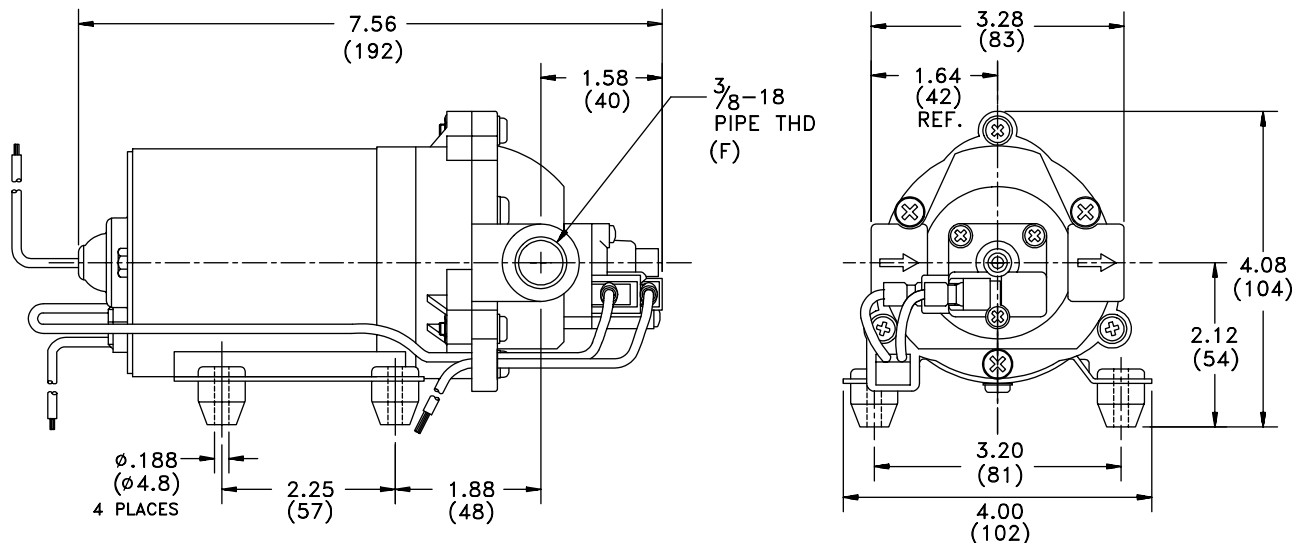

TEMPERATURE RISE

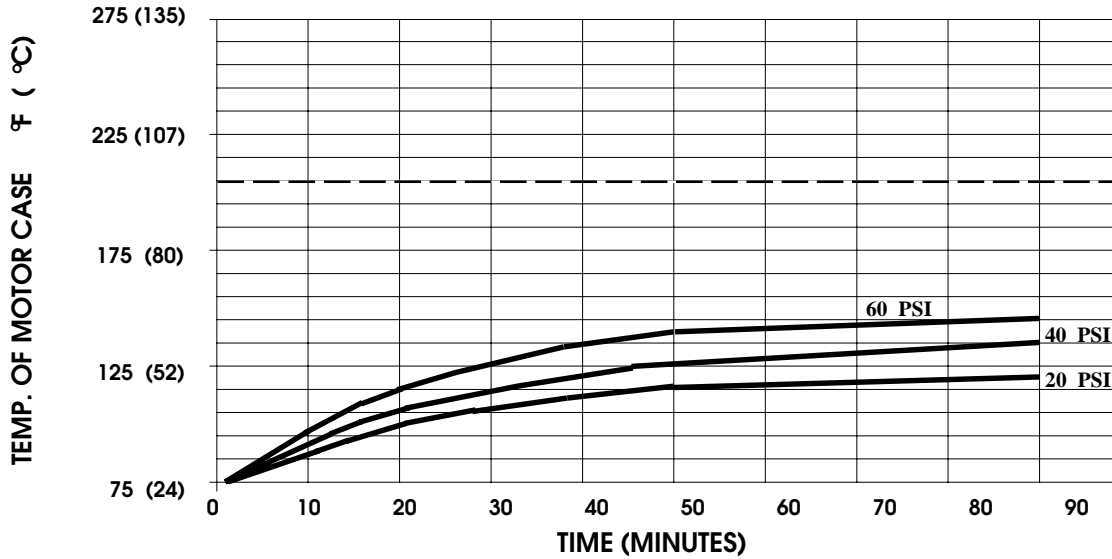

THIS GRAPH IS FOR USE AS A DESIGN GUIDE. IT IS BASED ON RUNNING CONTINUOUSLY WITH AN AMBIENT TEMPERATURE OF 70° F IN STILL AIR. THE THERMAL BREAKER WILL OPEN WHEN THE CASE TEMPERATURE REACHES 205° F.

[----- TRIP POINT OF THERMAL PROTECTOR]

TYPICAL PERFORMANCE

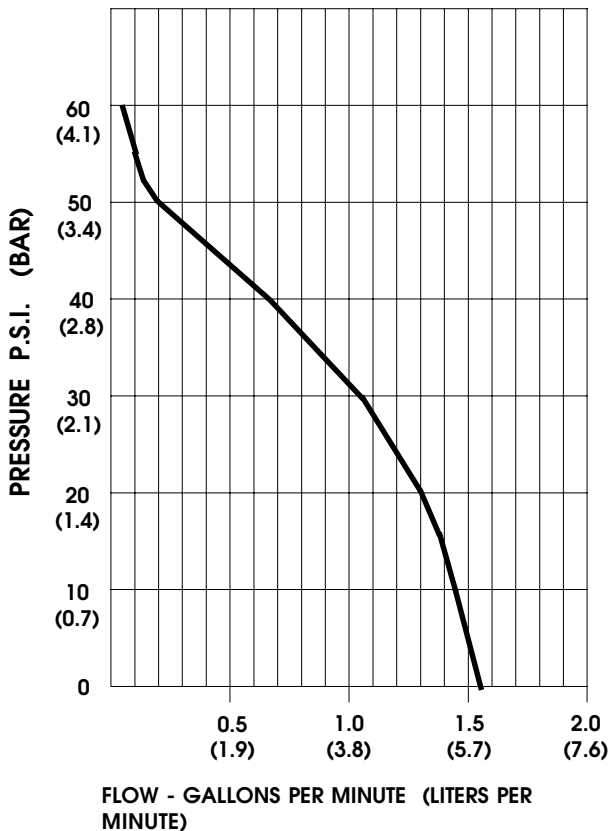

PRESSURE (PSI)	FLOW (GPM/LIT)	RPM MIN/MAX	CURRENT (AMPS)	VOLTAGE (VOLTS)
OPEN	1.56/5.9	2276/2290	0.31	115 VAC
10	1.46/5.5	2150/2160	0.34	"
20	1.29/4.9	2015/2035	0.40	"
30	1.05/4.0	1890/1945	0.45	"
40	0.67/2.5	1785/1865	0.49	"
50	0.19/0.7	1720/1790	0.52	"
60	0.05/0.1	1715/1770	0.54	"

-SPECIFICATIONS SUBJECT TO CHANGE WITHOUT NOTICE.

-ALL DATA BASED ON TESTING WITH WATER.