

# Quick Change Quad Manifolds

For use with Everpure quick-change cartridges



## APPLICATIONS

Fountain	Tea
Ice machines	Whole store
Coffee	

## FEATURES AND BENEFITS

Commercial-grade filter heads for Everpure filter cartridges.

Optional built-in water shut-off valve and flushing valve makes cartridge change-outs easy.

Cartridge nesting feature provides a more secure and durable fit.

Includes mounting box bracket and screws for fast and easy installation. No extra mounting plate is required.

Built-in water pressure gauge helps monitor proper flow.

Modular design of box bracket allows for future retrofitting of add-on components without disassembly of system.

All wetted parts have successfully passed NSF extraction tests.

Engineered for durability, strength and longevity. Will not corrode.

Includes E110 or E210 pre-filter cartridge and ScaeStick®.

## OPERATIONAL TIPS

Change cartridges on a regular 6 month preventative maintenance program.

Change cartridges when capacity is reached or when pressure decreases.

Everpure water treatment systems (excluding replaceable elements) are covered by a limited warranty against defects in material and workmanship for a period of five years after date of purchase. Everpure replaceable elements (filter cartridges and water treatment cartridges) are covered by a limited warranty against defects in material and workmanship for a period of one year after date of purchase. See printed warranty for details. Everpure will provide a copy of the warranty upon request.



QC71 Quad Head: EV9336-11



Coldrink/Insurice Quad Manifold with 20" Prefilter: EV9293-24



Coldrink/Insurice Quad Manifold with 10" Prefilter: EV9293-04



High Flow CSR Quad Manifold with 20" Prefilter: EV9294-24



High Flow CSR Quad Manifold with 10" Prefilter: EV9294-04

EC110 replacement cartridge: EV9534-12 (12 PK)

EC210 replacement cartridge: EV9534-26 (6 PK)

## SPECIFICATIONS

Dimensions:	Model	Dimensions
	EV9336-11	24.60" W x 8.94" H x 6.13" D (62.48 x 22.70 x 15.57 cm)
	EV9293-04	29.365" W x 15.287" H x 6.13" D (74.59 x 38.83 x 15.57 cm)
	EV9293-24	29.365" W x 25.377" H x 6.13" D (74.59 x 64.46 x 15.57 cm)
	EV9294-04	33.575" W x 16.527" H x 6.942" D (85.28 x 41.98 x 17.63 cm)
	EV9294-24	33.575" W x 25.377" H x 6.942" D (85.28 x 64.46 x 17.63 cm)
	EV9534-12 (12 PK)	9.8" H x 3.38" Ø (24.90 x 8.58 Ø cm)
	EV9534-26 (6 PK)	20" H x 3.38" Ø (50.8 x 8.58 Ø cm)

Electrical Connection: None

# Quick Change Quad Manifolds

EV9336-11, EV9293-04, EV9293-23, EV9294-04, EV9294-24

## INSTALLATION TIPS

Mounts directly onto flat surface. Install vertically so cartridge hangs down.

Allow 2½" clearance below the cartridge for easy cartridge replacement.

Flush filter by running water through filter according to cartridge instructions.

Refer to Installation, Operation & Maintenance Manual for cartridge flushing and start-up.

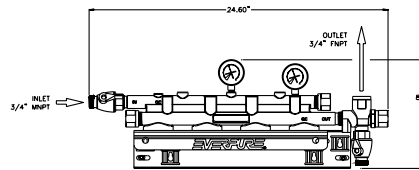

QC71 Quad Head: EV9336-11

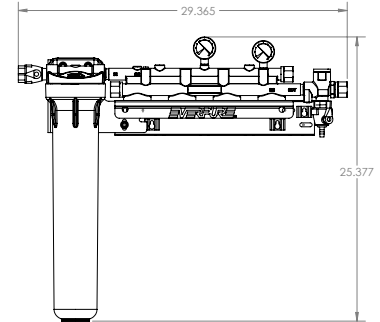

Coldrink/Insurice Quad Manifold with 20" Prefilter: EV9293-24

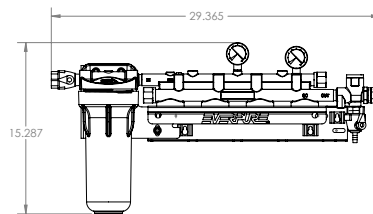

Coldrink/Insurice Quad Manifold with 10" Prefilter: EV9293-04

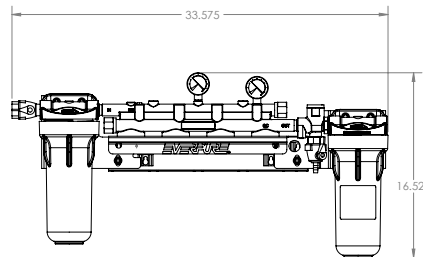

High Flow CSR Quad Manifold with 10" Prefilter: EV9294-04

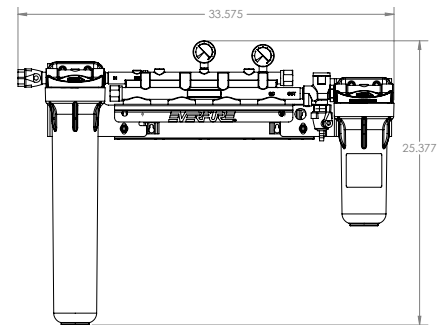

High Flow CSR Quad Manifold with 20" Prefilter: EV9294-24

Everpure reserves the right to update specifications, change prices, or make substitutions without notice.

QC-Quad Manifolds AP11



Visit our website at [www.everpure.com](http://www.everpure.com)

Everpure-SHURflo India  
Green Boulevard, B-9/A, 7th Floor -  
Tower B Sector 62, Noida - 201301  
TEL: 91.120.419.9444  
FAX: 91.120.419.9400  
EMAIL: [indiacustomer@pentair.com](mailto:indiacustomer@pentair.com)

Everpure-SHURflo Japan Inc.  
Hashimoto MN Bldg. 7F  
3-25-1 Hashimoto, Midori-ku  
Sagamihara-Shi Kanagawa 252-0143  
JAPAN  
TEL: 81.(0)42.775.3011  
FAX: 81.(0)42.775.3015  
EMAIL: [info@everpure.co.jp](mailto:info@everpure.co.jp)

Everpure-SHURflo China  
21F Cloud 9 Plaza, No 1118,  
Shanghai, 200052  
CHINA  
TEL: 86.21.3211.4588  
FAX: 86.21.3211.4580  
EMAIL: [China.Water@Pentair.com](mailto:China.Water@Pentair.com)

Pentair Filtration Solutions, LLC  
World Headquarters-Everpure/SHURflo  
North and South America Sales  
1040 Muirfield Dr.  
Hanover Park, Illinois 60133  
USA  
TEL: 800.942.1153 (US only)  
TEL: 630.307.3000  
FAX: 630.307.3030  
EMAIL: [cseverpure@pentair.com](mailto:cseverpure@pentair.com)

Everpure-SHURflo Australia  
2 Redwood Drive  
Notting Hill  
Victoria, 3168  
AUSTRALIA  
TEL: 011.61.39.574.4000  
FAX: 011.61.39.562.7237  
EMAIL: [au.everpure@pentair.com](mailto:au.everpure@pentair.com)

Everpure-SHURflo Southeast Asia  
18 Boon Lay Way  
#04-110/111  
TradeHub 21, 609966  
SINGAPORE  
TEL: 65.6795.2213  
FAX: 65.6795.2219  
EMAIL: [cseverpure@pentair.com](mailto:cseverpure@pentair.com)

Everpure-SHURflo Europe  
Pentair Water Belgium bvba  
Industriepark Wolfstee  
Toekomstlaan  
30 B-2200 Herentals, BELGIUM  
TEL: +32.(0).14.283.500  
FAX: +32.(0).14.283.505  
EMAIL: [sales@everpure-europe.com](mailto:sales@everpure-europe.com)