



EV9797-50

Kleensteam CT

Total water treatment system for steam applications



Kleensteam CT System: EV9797-50

4CB5 Replacement Cartridge: EV9617-11

SS-10 Cartridge: EV9799-02

BENEFITS

A total system delivering high quality filtered water with cleaning and deliming capabilities

Sophisticated Hydroblend compound prevents limescale formation in high temperature steam applications

Fine filters incoming water to improve the performance, maximize energy efficiency and increase the life of steam equipment

Reduces chlorine-induced corrosion

System is simple to install, operate and maintain

Easy deliming with Everpure's ScaleKleen, which is fed directly into the boiler through the SR-X bowl without boiler disassembly or the use of dangerous acids

Longer lasting SS-10 cartridge is more effective in higher alkalinity/hardness/TDS/temperature installations.

Scalestick is NSF Certified under NSF/ANSI Standard 42 for material requirements only

INSTALLATION TIPS

Choose a mounting location suitable to support the full weight of the system when operating

Use 3/8" water line

Connect the system to the boiler water only! Do not connect to the condenser!

Install vertically with cartridges hanging down

Allow 2-1/2" clearance below the cartridge for easy cartridge replacement

Flush cartridges by running water through filter for five minutes at full flow

OPERATION TIPS

Change 4CB5 cartridge on a regular 6 month preventative maintenance program

Change SS-10 cartridge before Hydroblend™ compound is completely used up

Change cartridges when capacity is reached or when pressure falls below 10 psi

Service flow rate must not exceed 1.67 gpm

Always flush the filter cartridge at time of installation and cartridge change

APPLICATION/SIZING

For commercial steam applications

For use with countertop steamers

Kleensteam CT

SPECIFICATIONS

Overall Dimensions:
15.23"H x 13.72"W x 6.23"D

Inlet connection: 3/8"

Outlet connection: 3/8"

Service Flow Rate:
Maximum 1.67 gpm (6.3 Lpm)

Pressure Requirements:
10 psi -125 psi (0.7 – 8.6 bar), non-shock

Maximum water temperature at inlet:
80°F (27°C)

Alkalinity range:
2 to 12 grains per gallon

No electrical connection required

Shipping Weight: 15 lbs.

Operating Weight: 18 lbs.

The contaminants or other substances removed or reduced by this drinking water system are not necessarily in your water. Do not use with water that is microbiologically unsafe or of unknown quality without adequate disinfection before or after the system. Systems certified for cyst reduction may be used with disinfected water that may contain filterable cysts.

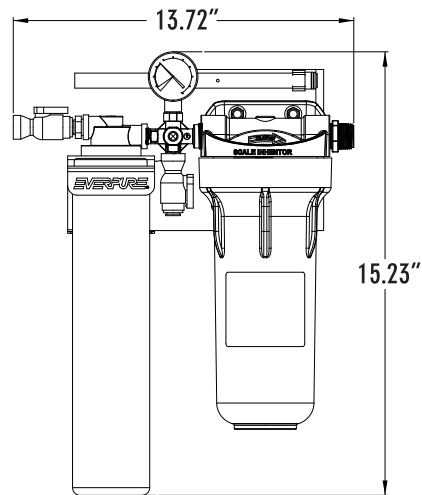

WARRANTY

Everpure water treatment systems (excluding replaceable elements) are covered by a limited warranty against defects in material and workmanship for a period of five years after date of purchase. Everpure replaceable elements (filter cartridges and water treatment cartridges) are covered by a limited warranty against defects in material and workmanship for a period of one year after date of purchase. See printed warranty for details. Everpure will provide a copy of the warranty upon request.

EVERPURE®

Worldwide Headquarters:
EVERPURE, LLC
1040 Muirfield Drive
Hanover Park, Illinois 60133
Toll Free (800) 323-7873
Tel (630) 307-3000
Fax (630) 307-3030
<http://www.everpure.com>

In Europe:
Pentair Water Belgium B.V./B.A.
Industriepark Wolfstee
Toekomstlaan 30
B- 2200 Herentals
BELGIUM
TEL: +32.(0).14.283.500
FAX: +32.(0).14.283.505

In Japan:
Hashimoto MN Bldg. 7F
3-25-1 Hashimoto Sagamihara-Shi
Kanagawa 229-1103
JAPAN
TEL: 81.(0)42.775.3011
FAX: 81.(0)42.775.3015