

Aquajet RV Water System Pumps

55AQUAJET-AES – 3.4 GPM/12VDC, WITH FUSE
55AQUAJET-OES – 3.4 GPM/12VDC, NO FUSE
55AQUAJET-ARV – 5.0 GPM/12VDC, WITH FUSE
55AQUAJET-ORV – 5.0 GPM/12VDC, NO FUSE

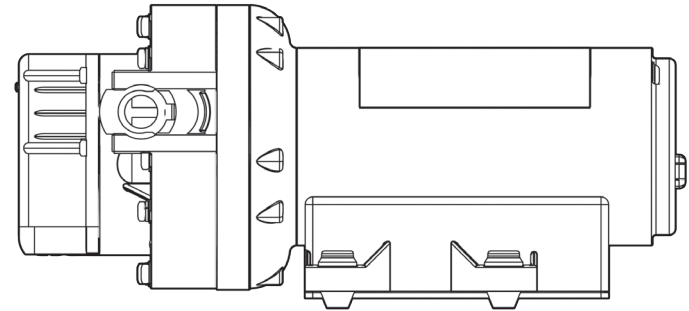

User's Manual and Installation Guide

Please read the following instructions before attempting an installation. When properly installed, Aquajet Series pumps can be used in virtually any existing RV.

If you prefer to have the pump professionally installed, contact Remco (763-253-4743) to locate your nearest authorized service center.

WARNING

The 5-chamber Aquajet Series pumps are more powerful than most existing RV water pumps and, as a result, may draw more current (Amps) than the pump(s) they replace. It is imperative that any power supply, fuses/circuit breakers, wiring, switches, connectors, or controllers that are used to supply 12 VDC to the pump are adequately sized. Inadequately sized components may overheat, causing an electrical fire.

When installing an Aquajet Series pump, **positive voltage (+12VDC) must be connected to the Aquajet's red fused leadwire**. Reversing polarity will instantly blow the fuse and may permanently damage the controller.

If you are uncertain with respect to any of this information, Remco highly recommends that a qualified technician perform your installation and determine the existing polarity of your current wiring.

Safety Tips

1. Never operate the pump in an atmosphere where flammable gases may be present, since arcing at the motor brushes or switch contacts may cause an explosion.
2. After extended operation, or if malfunctioning, metal surfaces of the pump may become hot and cause burns if touched. If this occurs, disconnect electrical power and wait 30 minutes before touching pump.
3. Never mount the pump where the surface temperature of the motor or the controller (200 F maximum) may cause ignition of the surrounding materials.
4. Do not wrap the pump with an insulating material or enclose it so tightly that air circulation around the pump is prevented. The pump will generate approximately the same amount of heat as a 75 watt lightbulb.
5. The pump should be mounted in a dry location away from any heat source(s).
6. Pumphead materials are designed for use with potable water only and should never be used with petroleum products.
7. The pump is equipped with a pressure sensing demand switch which controls the maximum operating pressure as set at the factory. Never subject the pump to pressures above 90 PSI maximum.

8. Always consider electrical shock hazards when working with and handling electrical equipment. If uncertain in your abilities, please consult an electrician.
9. 55Aquajet ORV, OES, ARV and AES Series pumps are equipped with an automatically resetting thermal protector. If a pump is not running, it may restart at any time.
10. Both the 55Aquajet ARV and AES Series include a fuse-holder. It is important to use only a 15 amp AGC automotive type fuse for the Aquajet RV Series and a 10 amp AGC fuse for the Aquajet ES Series. Once again, use only these types of fuses with these specific pumps.
11. It is necessary to use a screen filter between the water holding tank and the pump to prevent debris from entering the pump. Particulate matter may cause the valves inside the pump to stick open. This filter needs to be cleaned on a regular basis, or it will restrict water to the pump.
12. Winterizing the pump: If water is not drained from the system during freezing temperatures, damage to the pump and the plumbing is likely:
 - a. Drain the water holding tank.
 - b. Open all faucets and run the pump to expel all water.
 - c. Disconnect inlet and outlet fittings and run pump to remove residual water from the pump.
 - d. Leave fittings disconnected from pump.

Installer qualifications

If you intend to install an Aquajet Series pump without professional assistance, you should clearly be “handyman” competent enough to do simple low voltage electrical wiring, crimp connectors, obtain voltage measurements, understand polarity as well as schematics which illustrate relay connections. Additionally, you should be comfortable with water system plumbing, installing hose clamps, using Teflon tape, and removing/re-tightening compression fittings.

A typical Aquajet installation takes between 1 - 2 hours and requires the following:

Basic Tools

Flashlight, Voltmeter, Wire Stripper/Crimper, Standard Screwdriver, Phillips Screwdriver, Hose cutter, 8" Crescent Wrench, bucket, towels.

Depending on the RV's layout, electrical and plumbing configuration, additional hardware may be needed for a successful pump installation.

Electrical Supplies

Relay, associated connectors, wire, electrical tape and mounting hardware may be needed. For plumbing the pump to rigid (polybutylene or PEX) tubing, a flexible connector hose is strongly recommended for the pressure side. If the Aquajet pump is mounted at a different location than the old pump, flexible connector hoses will be required on both the inlet and outlet side. A screen-filter should always be used between the RV water tank and the pump.

Planning the installation

("55AQUAJET ORV and ARV SERIES" ONLY):

1. Determine whether or not your RV is currently using an 'Intellitec' pump controller (i.e. three or more "momentary" type switches which can be used to turn the pump on/off.). There are at least four (4) different types of Intellitec controllers currently in use, but not all of them can be used with the Aquajet RV. Specifically, only a four terminal, 10 or 15 Amp rated Intellitec controller can be used to directly control the Aquajet RV. Intellitec 7 Amp, 3 Amp or non-rated controllers should NEVER be used to switch the load of the Aquajet RV.

The Intellitec controllers are typically located in the pump compartment (on some Fleetwood vehicles, however, they are located near the circuit breaker panel under the refrigerator). Once you've located the controller, before taking anything apart, make a sketch of the existing wiring including the colors of the wires and how they are attached. If you do have an Intellitec controller that does not say either "10 Amp" or "15 Amp" on the label, then you must either:



WARRANTY

Aquajet RV Series | Aquajet ES Series

Remco Industries ("Remco") warrants its Model Aquajet RV Pumps (Part Numbers 55AQUAJET-ORV, 55AQUAJET-ARV, 55AQUAJET-OES, and 55AQUAJET-AES) to be free from defects in material and workmanship under the following terms:

The duration of the warranty will be for a period of 2 years from date of shipping from a Remco warehouse. Remco's obligation under this warranty shall be limited to, replacing or repairing at Remco's discretion, any such product or part which is returned to Remco's factory with a Return Material Authorization Number (RMA No.) and upon evaluation, product is deemed defective under the terms of warranty to Remco's satisfaction. Transportation charges will have to be pre-approved by Remco or prepaid by customer. No credit will be allowed against future purchases for items returned as defective under the terms of the warranty.

This warranty does not extend to any products, which have been altered or modified outside the Remco factory, to any products that have not been properly maintained, nor does it apply to units that are returned in an unassembled condition. Furthermore, this warranty does not cover any damage or defects occurring from customer's failure to follow pump label instructions or Operational and Installation Guidelines. The warranty guarantees that the pump will perform to Remco's flow and pressure specifications throughout the life of this warranty, under normal operating conditions. The warranty does not cover wear, appearance, misuse, abuse, misapplication or external water damage. If the returned product is not found to be defective under the terms of this warranty, customer will be responsible for repair or replacement costs.

This is a Limited Warranty. It covers the product only and the extent of the coverage is limited only to the cost of the product. As the manufacturer has no control over shipping, handling and installation, the warranty cannot cover water damage, or any other damage, caused by a leak or other malfunction.

THIS WARRANTY IS IN LIEU OF ALL WARRANTIES, EXPRESSED OR IMPLIED, INCLUDING WARRANTIES OF MERCHANTABILITY OR FITNESS FOR A PARTICULAR PURPOSE. NO PERSON IS AUTHORIZED TO GIVE ANY OTHER WARRANTY OR ASSUME OBLIGATION OR LIABILITY ON REMCO'S BEHALF. REMCO SHALL NOT BE LIABLE FOR ANY INDIRECT, INCIDENTAL, PUNITIVE OR CONSEQUENTIAL DAMAGES OF ANY KIND INCURRED BY THE REASON OF THE USE OR SALE OF ANY DEFECTIVE PRODUCT OR PART. THIS WARRANTY SHALL BE GOVERNED BY THE LAWS OF THE STATE OF MINNESOTA, WITH ANY WARRANTY RELATED DISPUTE VENUED OR HEARD IN THE STATE OF MINNESOTA.

14260 23RD AVE. N., PLYMOUTH, MN 55447
PHONE: 1-800-228-2481 OR 763-253-4740, FAX: 763-253-4741
www.remcoindustries.com | www.remcotowing.com

9. ELECTROMAGNETIC INTERFERENCE

Cause	Solution
Noise can be heard in Stereo System, or TV picture affected when pump is running	Install EMI filter in line with pump. P/N 21-256
Operation of Heating/Cooling System changes when pump is running	Install EMI filter in line with pump. P/N 21-256

- a. Replace it with a 10 or 15 Amp rated controller. For your convenience, Intellitec's phone number is (708) 268-0010.
 - b. Procure a 30 Amp rated relay (through either a local automotive store or directly through the Remco catalog, product number 20-267) to augment your existing controller. Please refer to Figures 3, 4, page 14 and Figure 8, page 15.
2. Determine whether or not your present wiring is capable of supplying 10 Amps without generating an excessive voltage drop. For a 10 Amp load, 14 AWG can typically be used up to 10 ft distances, 12 AWG up to 20 ft distances, and 10 AWG for distances of more than 20 ft. You can also determine if your wiring is adequate by using a Voltmeter, as follows:
- a. Probe inside the wirenuts that connects the existing pump.
 - b. Write down voltage at pump with all valves closed and pump inactive. This is your nominal battery voltage.
 - c. Open a faucet or faucets so you get the pump running continuously.
 - d. Measure the voltage again at the pump wirenuts.
 - e. Note the running voltage.
 - f. Subtract the running voltage from the nominal voltage. This is your "voltage drop".

If the voltage drop with your existing pump (typically 5 Amps) exceeds 1 Volt you will need to pull a new heavier (10-12AWG) 'hot' wire to the pump AND use a 30 amp relay (referenced in section 1b above) to connect your Aquajet pump (see Figures 1 and 2, page 13).

Typically, if your RV uses one (1) switch to control the pump, the wiring is short and should prove sufficient. If your RV has two (2) rocker-style switches you will see significant voltage drops and thus both the relay and the new heavier “hot wire” will be required.

Locate the battery and the fusebox for the pump. Identify which fuse protects the pump. Determine which source of power from which it will be simplest to pull a hot wire to the pump. Plan the routing of the wire and approximate the length of wire required.

3. Determine the optimal location for the Aquajet RV. If possible, plan to position the Aquajet pump horizontally, with its rubber feet resting on a “floor-like” surface rather than mounted on a wall. Take into consideration the 1/16” hex adjustment screw on the Aquajet pump-head so you have access to it after the installation. Never mount the pump in an area where gasoline vapors are present, as the motor and heatsink of the speed-controller may get hot (up to 200 F) after extended running. Locate the Aquajet pump at least one inch away from any wall surface. In most cases, you’ll be able to mount the Aquajet pump very close to where the old pump was located.
4. Survey the existing plumbing and identify the suction line (i.e. the line going from the water holding tank to the pump). For the quietest possible operation of the Aquajet pump, you should try to isolate the pump mechanically from your RV’s typically hard Polybutylene or PEX tubing. If your RV is currently plumbed with soft-walled, reinforced hose (see Figure 5, page 15), then your system should be perfectly sufficient as is. By installing a piece of IAPMO approved cold water hose (such as ‘Accuflex’ Series 136) between the pump outlet port and your RV’s hard plumbing, you will achieve the quietest possible pump operation. Remco also offers, as an optional accessory, a 39” long pre-assembled hose with fittings (Remco product number 25-174) that will adapt directly to the Aquajet RV and your existing plumbing. Please refer to Figures 6 and 7, page 15.

7. LOW FLOW/PRESSURE

Cause	Solution
Leak on inlet side of pump	Check tightness of hose connections, check hose for possible damage.
Air in pump	Purge air (refer to User’s guide).
Low voltage to pump	Change battery/power supply Check wire gauge (refer to User’s guide).
Debris under valves.	Flush pump and/or disassemble and clean valves.
Motor malfunction	Replace pump.

8. PUMP IS EXCESSIVELY NOISY

Cause	Solution
Pump is plumbed directly to rigid tubing	Install pulsation dampener. P/N 25-174 (elbow fittings) P/N 25-175 (straight fittings)
Restrictive inlet, pump is cavitating	Check plumbing. Water should free flow from tank at 2 GPM minimum.
Pump head loose on motor	Tighten screws.
Pump mounting is loose	Tighten screws.
Pump mounting is too rigid	Use flexible tubing and make sure the dampening rubber feet are used.
Defective motor/drive	Replace pump.

5. PUMP LEAKS

Cause	Solution
Perforated diaphragm	Please contact factory, 1-800-228-2481.
Inlet/outlet fittings leak	Replace O-rings and/or fittings.

6. PUMP KEEPS RUNNING WHEN WATER IS NO LONGER DEMANDED

Cause	Solution
Diverter valve in “fill” mode	Close and/or rotate any valve used for filling water tank.
Water tank empty	Fill up tank.
Leak on outlet side of pump	Check tightness of hose connections, check hose for possible damage.
Air leak on inlet side of pump	Check tightness of hose connections. Check inlet hose, filter, and valves for possible damage. Purge air (refer to User’s Guide).
Speed controller malfunctioning	Please contact factory, 1-800-228-2481.
Low voltage to pump	Change battery/power supply. Check wire gauge (refer to Aquajet User’s Guide).

- At the end of your survey you should have determined how to wire the Aquajet pump. Your alternatives are illustrated in Figure 1, page 13 (“no change”, also applicable for single switch systems), Figure 2 page 13, Figures 3, 4 or 8, page 15. You should also have determined how to plumb the pump. Your options are Figures 5, 6 or 7, page 15. Always make sure you have all hardware needed before you start the actual installation.

Planning the installation

("55AQUAJET OES and AES SERIES" ONLY):

The Aquajet OES and AES Series pumps were designed specifically for the RV aftermarket and, as a result, should be compatible with the existing electrical wiring for most RVs. Because these pumps use a lower amperage motor than the Aquajet ORV and ARV Series, installation is generally simplified. Oftentimes, installation is as simple as removing the wirenuts connecting the existing water pump and then reconnecting the existing wiring (keeping careful track of polarity) to the Aquajet pump.

Before installation, however, you should insure that your particular RV does not require any electrical modifications to run the Aquajet OES/AES, as follows:

1. Determine whether or not your existing wiring can supply 6.5 Amps to the Aquajet ES without generating an excessive voltage drop or overloading any control component. You should check specifically for three (3) things:
 - a. Determine whether your RV is currently using an Intellitec pump controller. The Aquajet ES Series is compatible with most common rated versions (7 Amp, 10 Amp, 15 Amp). However, if you have either a 3 Amp or non-rated controller, you should procure a 30 Amp rated relay to augment your existing controller. These 30 Amp relays are available through local automotive stores or through Remco directly (P/N 20-267). If necessary, refer to Figure 8, page 15 for additional information.
 - b. Check your RV Owner's Manual for the recommended fuse rating for the pump branch circuit. If your recommended rating is rated 10 Amps or more, you can proceed directly with the electrical installation. If your recommended rating is less than 10 Amps, you should procure a 30 Amp rated relay as referenced above.

3. PUMP RAPIDLY CYCLES ON/OFF WITHOUT WATER DEMAND

Cause	Solution
Leak on outlet side of pump	Check tightness of hose selections, check hose for possible damage.
Fill valve bypassing to tank	Replace fill valve.
Debris under valves	Flush pump in nominal flow direction. If necessary, disassemble and clean valves.

4. PUMP DOES NOT PRIME

Cause	Solution
Water tank empty	Fill up tank.
Leak on inlet side of pump	Check tightness of hose connections at pump, filter and tank. Check valves at inlet side.
Debris under valves	Flush pump (in nominal flow direction) with tap water at maximum flow possible.
Perforated diaphragm	Please contact factory, 1-800-228-2481.
Inlet or outlet plumbing restricted	Check plumbing. Water should free flow from tank at 2 GPM minimum.

Troubleshooting Guide

Aquajet RV Series | Aquajet ES Series

1. PUMP DOES NOT RUN

Cause	Solution
Tripped thermal protector/ blown fuse	Check fuse. If motor is overheated, allow it to cool down prior to restart.
Faulty wire connection or power source	Check battery/power supply, polarity, main switch and wiring.
Pressure switch malfunctioning	Replace switch assembly. P/N PSW-560
Motor malfunctioning	Replace pump.
Pump and/or motor is frozen	Thaw pump and system and check for damage. The pump/motor may become damaged when a frozen pump is started.

2. PUMP RAPIDLY CYCLES ON/OFF WITH WATER DEMAND

Cause	Solution
Hydraulic pulsations	Install pulsation dampener. P/N 25-174 (elbow fittings) P/N 25-175 (straight fittings)
Restriction on outlet side of pump, resulting in too much back pressure	Check inline filter, if any.

If necessary, please refer to Figures 1 and 2, page 13 for additional wiring instructions.

- c. If there are two (2) or more switches in your RV which independently control your pump, you may experience excessive voltage drops in your existing circuitry. Using voltmeter, test voltage at the pump with the pump running (refer to Figure 1, page 13). With either a fully charged battery or a running generator, you should be getting at least 11 volts at the pump. If not, you should procure a 30 Amp rated relay as referenced above.
2. Determine the optimal location for the Aquajet pump. If possible, plan to position the Aquajet pump horizontally, with its rubber feet resting on a “floor-like” surface rather than mounted on a wall. Take into consideration the 1/16” hex adjustment screw on the Aquajet pump-head so you have access to it after the installation. Never mount the pump in an area where gasoline vapors are present, as the motor and heatsink of the speed-controller may get hot (up to 200 F) after extended running. Locate the Aquajet pump at least one inch away from any wall surface. In most cases, you’ll be able to mount the Aquajet pump very close to where the old pump was located.
 3. Survey the existing plumbing and identify the suction line (i.e. the line going from the water holding tank to the pump). For the quietest possible operation of the Aquajet pump, you should try to isolate the pump mechanically from your RV’s typically hard Polybutylene or PEX tubing. If your RV is currently plumbed with soft-walled, reinforced hose (see Figure 5, page 15), then your system should be perfectly sufficient as is. By installing a piece of IAPMO approved cold water hose (such as ‘Accuflex’ Series 136) between the pump outlet port and your RV’s hard plumbing, you will achieve the quietest possible pump operation. Remco also offers, as an optional accessory, a 39” long pre-assembled hose with fittings.

(Remco product number 25-174) that will adapt directly to the Aquajet pump and your existing plumbing. Please refer to Figures 6 and 7, page 15.

Installation

- Using Voltmeter, determine polarity of the wiring to the existing pump(s).

Unfortunately, there is no standardized color scheme for RV wiring (most RVs, however, seem to use red for the positive lead and black for the negative lead). Regardless of your specific configuration, positive voltage (12VDC) must be connected to the RED (fused) leadwire of the Aquajet pump. Reversing this polarity will instantly blow the in-line fuse and may permanently damage the controller. Mark the positive (hot) RV wire with a piece of tape.

- Turn power "off" to existing pump(s).
- Open a faucet, bleed off all existing pressure, then close the faucet again.
- Disconnect the main power to the pump (either at battery or fuse panel).
- Remove the wire-nuts from the leads to the old pump.
- Steps 1 and 2 of the earlier 'Installation Planning' section should have determined the applicable wiring method. As appropriate, wire the Aquajet pump as per Figures 1, 2, 3, 4 or 8, pages 13-15.
- [For old pump outlets connected to hose, as in Figure 5, page 15] Insert O-ringed end of (Qest) threaded adapter into outlet port (marked with arrow pointing away from pump) of the Aquajet pump. Lock fitting in place by pushing down retainer slide.

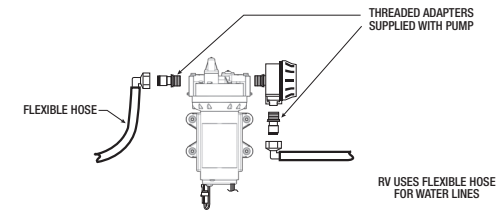

FIGURE 5

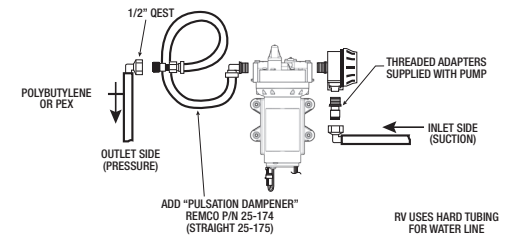

FIGURE 6

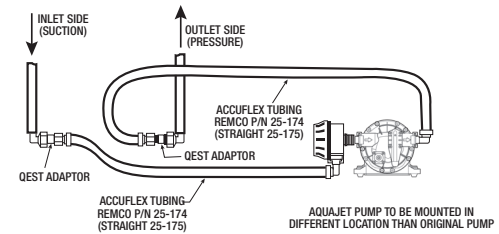

FIGURE 7

TO BATTERY +12V OR FUSE PANEL

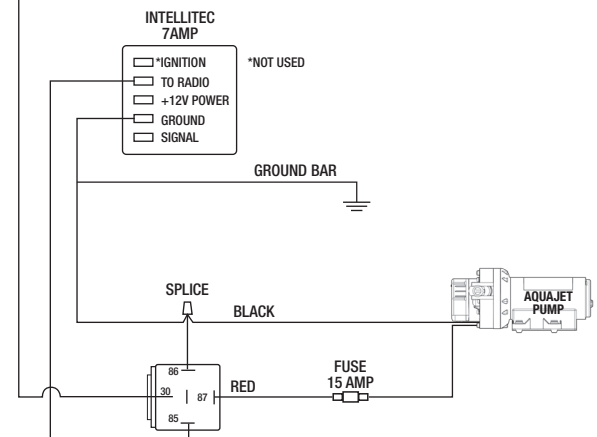
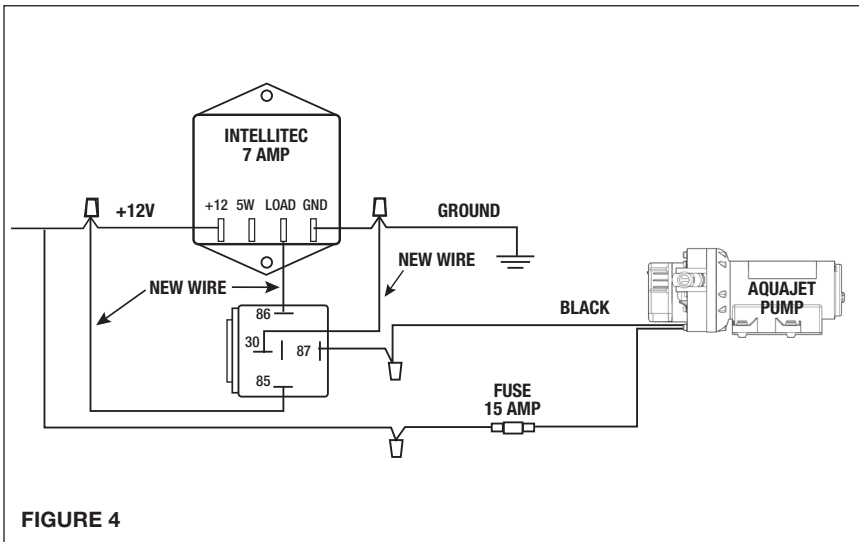
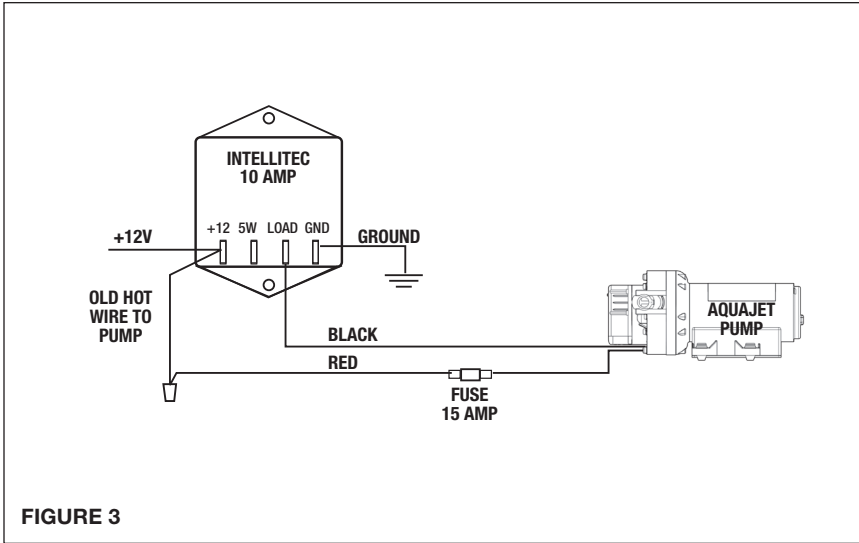

FIGURE 8



7b. [For old pump outlets directly connected to hard tubing, as in Figure 6, page 15].

Insert the O-ringed elbow fitting of the Accuflex hose adapter (sold separately) into the outlet port of the Aquajet pump. Lock fitting in place by pushing down retainer.

8a. [If the Aquajet pump is to be directly plumbed to the existing inlet filter/fitting, as in Figures 5 and 6, page 15].

Insert the O-ringed end of threaded adapter into the pump's inlet port (look for arrow pointing towards the center of the pumphead). Lock fitting in place by pushing down retainer slide.

8b. [If the Aquajet pump is to be remote mounted, as in Figure 7, page 15].

Insert the O-ringed elbow fitting of the Accuflex hose adapter (sold separately) into the inlet port of the Aquajet pump. Lock fitting in place by pushing down retainer slide.

9. Remove the mounting screws from the old pump.

10. Place a towel under the inlet port (suction side) of the existing pump(s) and quickly remove the connecting fitting/filter.

11. Re-attach the filter/inlet fitting to the applicable adapter on the inlet side of the Aquajet pump.

12. If an Accuflex hose adapter is used on the outlet side (see Figures 6 and 7, page 15), place the other end of the hose adapter up high. This should stop water from being siphoned out.

13. Place a towel under the outlet port (pressure side) of the existing pump(s) and remove the connecting fitting.

14. Remove the old pump.

15. Position the Aquajet pump into its intended mounting place.
16. Drive the mounting screws (Remco recommends #10 screws, 1.5" long, to be used with washers) into the floorboard. Be sure to stop just as the screw heads touch the washers so you do not compress the rubber mounting grommets.
- 17a. [If you are plumbing per Figure 5, page 15]
Place a bucket under you plumbing system's pressure hose, have an assistant open 2 inside faucets and drain water from the pressure line. Connect the pressure hose fitting to the Qest adapter on the pump outlet side.

- 17b. [If you are plumbing per Figures 6 or 7, page 15]
Place the open end of the Accuflex tubing from the Aquajet outlet port into the bucket.

18. Reconnect the main power to the pump/relay using fuse box or battery.

19. Have an assistant briefly power up the pump using one of the RV's standard "pump switches".

20. Water should be flowing into bucket (see Figures 6 and 7, page 15) or into the sinks (see Figure 5, page 15).

21. Allow Aquajet RV to run for 10-15 seconds to get rid of all air inside the pump, then power down the pump.

22. Coil the Accuflex outlet tubing (pulsation dampener) and connect the pressure side Qest fittings. Use tie-wraps if necessary to insure that the tubing will not rattle.

23. Power up the pump again and check for leaks. Tighten fittings where necessary.

24. Close all faucets and wait for the pump to slow down and eventually stop. If a continuous low 'whining' sound is heard from the pump, re-check the voltage at the pump terminals (it should be 10.5 V minimum). If necessary, use 1/16" hex-key and turn the pressure adjustment screw on the controller counter-clockwise.

25. Open the most commonly used faucet to a typical flow level. Observe the pump - it should be running continuously at a low speed. If the pump is "cycling", use 1/16" hex key to turn the pressure adjustment screw on the controller clockwise. Return to step 24 and verify that pump shuts off properly.

26. Your pump should now be ready for use. Power down the pump when there is no need for water.

