

MD-CN & MD-CE Water Filters

Part No. 255348 & 255350

EVERPURE®

WATER YOU CAN TRUST®

*Premium quality water filtration created
for use in Marine Applications.*



MD-CN Cartridge
P/N 255348 (6 pack)
Replaces P/N EV960123



MD-CE Cartridge
P/N 255350 (6 pack)
Replaces P/N EV961210



MD Single Head
P/N 169110 (1 Pack)
Replaces P/N EV927401
Designed for use with
MD-CN & MD-CE filter
cartridges.



MD Dual Head Assembly*
P/N 169111 (1 Pack)
Replaces P/N EV927402
Designed for use with
MD-CN & MD-CE filter cartridges.



MD Triple Head Assembly*
P/N 169112 (1 Pack)
Replaces P/N EV927403
Designed for use with
MD-CN & MD-CE filter cartridges.

BENEFITS

- Reduces chlorine taste and odor, bromine* and other off tastes and odors that can spoil food and beverages
- Reduces dirt larger than one-half micron in size
- Exclusive 1/2 micron precoat filtration removes >99% of asbestos fibers, and >99.95% of cysts such as *Cryptosporidium*, *Giardia*, *Toxoplasma* and *Entamoeba*

INSTALLATION TIPS

- Choose a mounting location which is suitable to support the full weight of the system when operating
- Use a 3/8" water line for the MD single head
- Use a 3/4" water line for the MD dual and triple heads
- Do not braze/solder fittings into head
- Never use a saddle valve for connection
- Do not exceed service flow rate (refer to other side)
- **Flush filter cartridges by running water to drain at full flow through the flushing valve for 5 minutes**

OPERATION TIPS

- Change cartridges:
 - on a regular 6 month preventative maintenance basis
 - when the pressure gauge indicates a pressure less than 10 psi when the system is operating

Always flush the filter cartridges after changing.

QUICK-CHANGE MD HEADS

- Cartridge heads are extremely durable and have corrosion-resistant exterior finishes to withstand severe marine environments.
- Each quick-change head or head assembly has its own built-in water shut-off valve and steel mounting bracket.
- Multiple heads are now molded as one piece to minimize leak points and improve strength.

* As tested by Everpure

SPECIFICATIONS

Dimensions

Single	24½"H* X 3¾"W X 4½"D
Dual**	27½"H* X 19"W X 6"D
Triple**	27½"H* X 23"W X 6"D

*Height of the MD-CN and MD-CE are approximately 6" less
 "H" dimension includes 2½" clearance for cartridge changing

Six-Pack Shipping Weights

MD-CN (6 pk)	P/N 255348	Replaces P/N EV960123	11 lbs
MD-CE (6 pk)	P/N 255350	Replaces P/N EV961210	14 lbs

Shipping Weight

Single Head	3 lbs (1.4 kg)
Dual Head**	7 lbs (3.2 kg)
Triple Head**	11 lbs (5 kg)

Operating Weight

Single	CN	6.25 lbs (2.8 kg)
Single	CE	8 lbs (3.6 kg)

Inlet Connection

¾" Female Pipe Thread (single)
¾" Female Pipe Thread (twin and triple)

Outlet Connection

¾" Female Pipe Thread (single)
¾" Female Pipe Thread (twin and triple)

Service Flow Rate

MD-CN	Single Head: 0.5 gpm (1.90 L/min)
MD-CE	Single Head: 1.5 gpm (5.67 L/min)

Capacity

MD-CN	1,500 gal (5,670 L)
MD-CE	3,000 gal (11,350 L)

Working Pressure

10-125 psi (0.69-8.6 bar), non-shock

Maximum Temperature

35-100°F (1.7-37.8°C)

LIMITED WARRANTY OF PHYSICAL QUALITY

If, within eighteen months after manufacture or twelve months after purchase (whichever occurs first), any part of Pentair Water Treatment/Plymouth Products manufacture which is returned to its factory, shipping charges prepaid, is found to be defective in material or workmanship in the judgement of Pentair Water Treatment/Plymouth Products' engineers, Pentair Water Treatment/Plymouth Products will repair or replace such part at no charge, f.o.b., Sheboygan factory. Pentair Water Treatment/Plymouth Products, however, shall not be liable for damages or delays caused by any defective material or workmanship, or by failure of any parts due to normal wear and tear. Pentair Water Treatment/Plymouth Products will not be responsible for products which malfunction due to user neglect or unauthorized modification.

NOTE: Some states do not allow limitations on how long an implied warranty lasts, so the above limitation may not apply to you. Similarly, some states do not allow the exclusion or limitation of consequential or incidental damages, so the above limitation or exclusion may not apply to you. This warranty gives you specific legal rights and you may also have other rights which may vary from state to state.

DIMENSIONS

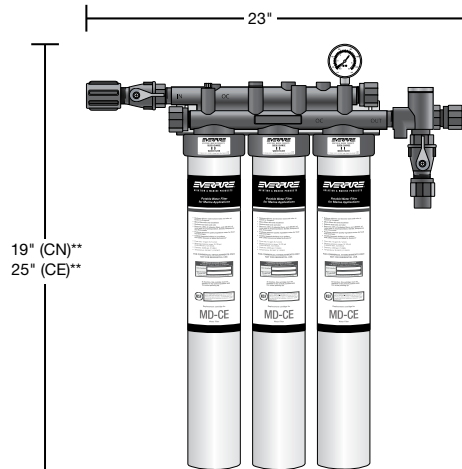
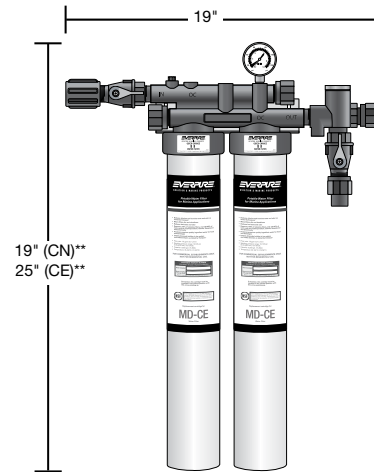

** The Dual and Triple Head Assemblies are Not Performance Tested or Certified by NSF.

Allow 2½" additional height for cartridge change on all systems.



The MD-CN and MD-CE are Tested and Certified by NSF International against NSF/ANSI Standard 42 for the reduction of Chlorine, Taste and Odor, and Particulate Class I. Standard 53 for the reduction of Asbestos, Cysts, and Turbidity.

Pentair Filtration, Inc.

502 Indiana Avenue - P.O. Box 1047
 Sheboygan, Wisconsin 53082-1047
 Phone 866.873.7506 Fax 888.203.7361
 International Phone 920.457.9435 International Fax 920.457.2417
 www.everpure.com

