

WATTS

ZERO WASTE REVERSE OSMOSIS RETROFIT KIT INSTALLATION INSTRUCTIONS

Parts Included in the Kit

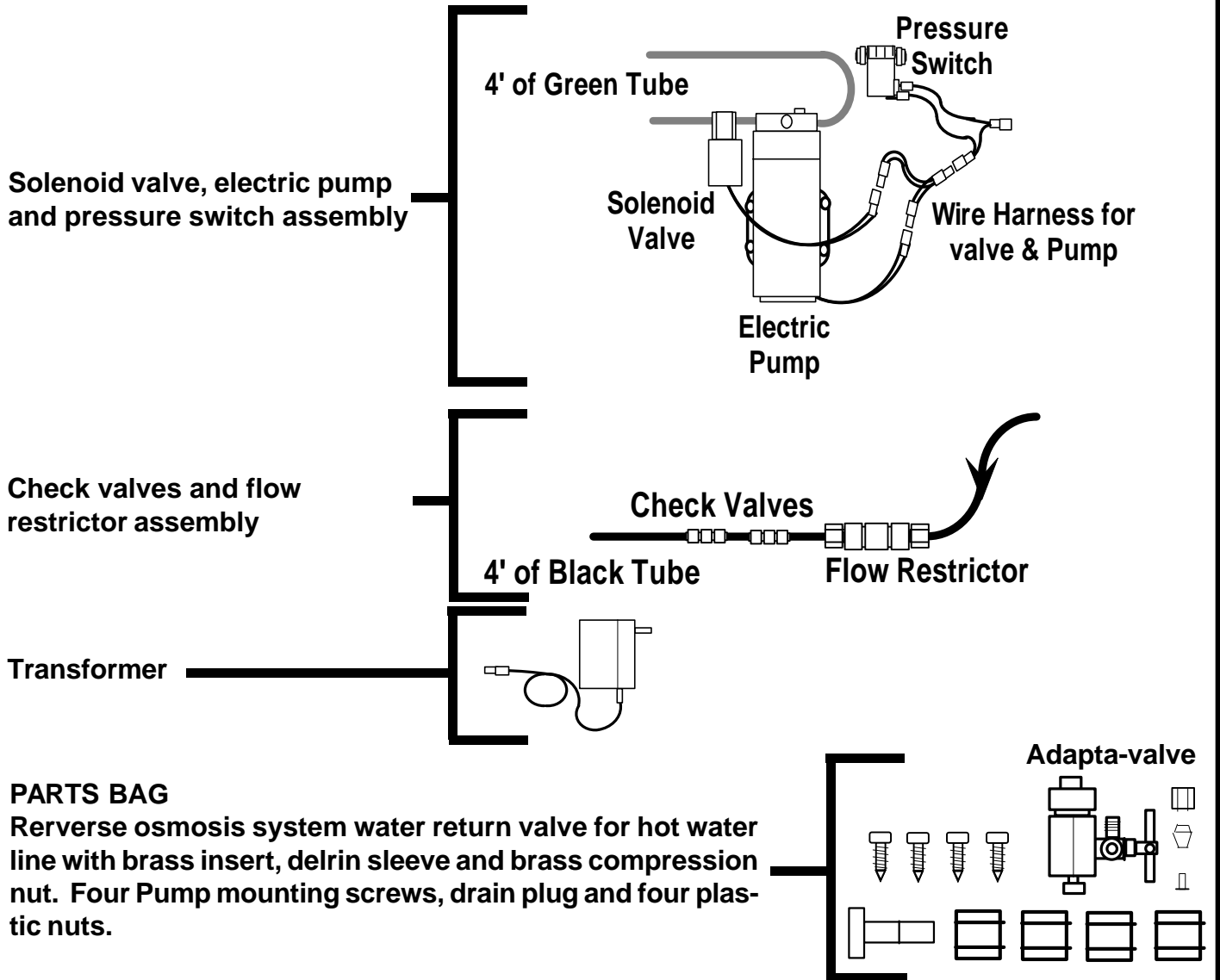

Recommended Tools for Installation

Sharp knife
5/8" wrench
Philips screwdriver / Screw gun
Channel lock
Cressant wrench

Watts Premier, Inc.
1725 W. Williams Dr
Phoenix, AZ 85027

Phone: 800-752-5582
Fax: 623-931-0191
www.wattspremier.com

Installation Steps for Zero Waste Reverse Osmosis Retrofit Kit

Note: RO unit must be installed a minimum of 25 feet from hot water heater.

- Step 1 Turn off the hot (#1 in Fig. 1) and cold (#2 in Fig. 1) water supply lines to the sink at the angle stop valves. If system is hooked up to an ice maker close the valve to the ice maker.
- Step 2 Drain tank by opening the RO faucet (#3 in Fig. 1).
- Step 3 Disconnect the standard hot water sink faucet supply line and install the included water supply valve to the hot water angle stop (#4 in Fig. 2). Then reconnect the standard sink faucet supply line to the included water supply valve. If the standard hot water sink faucet supply line does not disconnect from the hot water angle stop, the included hot water supply valve will have to be installed at the hot water sink faucet fitting (#21 Fig. 2).
- Step 4 Remove waste water tube on membrane housing (#5 in Fig. 1).
- Step 5a **If system has an air gap faucet**, cut the air gap inlet tube approximately 6" from the faucet connection (#6 in Fig. 1). This tube will not be reconnected to anything.
- Step 5b **If system has a non air gap faucet**, disconnect at drain saddle (#7 in Fig. 1) and use the plug provided to seal opening where the tube was connected with drain saddle.
- Step 6 Attach the short tube of the new flow restrictor assembly on the membrane housing at #8 in Fig. 2).
- Step 7 Attach the long tube from the flow restrictor assembly to the hot water supply valve (#9 in Fig. 2).
- Step 8 Remove the inlet water tube going into the membrane filter vessel (#10 in Fig. 2).
- Step 9 Attach the tube from the solenoid (#11 in Fig. 2) to membrane inlet (#10 in Fig. 2).
- Step 10 Remove the outlet tube coming from the last prefilter bowl's lid (#13 Fig. 2).
- Step 11 Attach the new tube that is attached to the pump inlet (#12 Fig. 2) to the outlet of the last prefilter bowl's lid (#13 in Fig. 2).
- Step 12 Mount the solenoid and pump in a convenient location. Be sure that the tubes are not kinked.
- Step 13 Locate the outlet of RO water from membrane filter vessel (#14 in Fig. 1). Cut the tubing at the shut off valve (#15 in Fig. 1).
- Step 14 Locate the tube going to the tank (#16 in Fig. 1). Follow it back to automatic shut off switch and cut the tube at the shut off valve (#17 in Fig. 1).
- Step 15 Insert the tube from step 13 by pushing it into the connector on the side of the pressure switch (#18 in Fig. 2). Insert the tube from step 14 into the connector on the other side (#19 in Fig. 2). The switch has a quick disconnect fittings which require the tube to be inserted and pushed firmly into the fitting. To disconnect, push on the plastic ring while pulling the tube.
- Step 16 All Electrical connections are color coded for your convenience. Connect the transformer to the wiring harnesses (#20 in Fig. 2).
- Step 17 Turn on the hot and cold water supply lines (open ice maker valve after tank has filled, if connected to an ice maker.) Check for leaks and tighten fittings as needed.
- Step 18 Plug the transformer into an electrical outlet (not the garbage disposal outlet) and let the unit run for two minutes. Check for leaks and tighten fittings as needed.
- Step 19 Periodically check unit for leaks during the first 5 days of operation. If leaks develop, please shut off the unit by closing the small valve on the angle stop valve and call customer service for troubleshooting. (Customer service is available 8:00am to 5:00pm Arizona time at 1-800-752-5582.

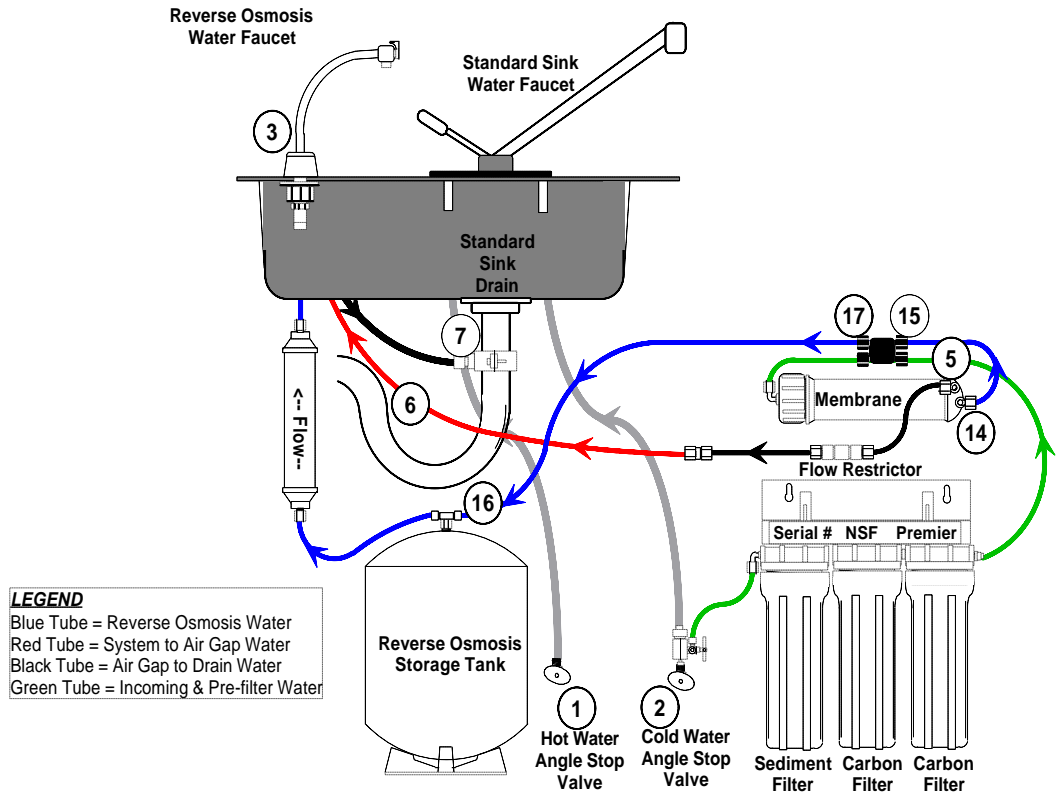

Figure 1 - Standard Reverse Osmosis System Before Kit is Installed

Rev 9/19/02

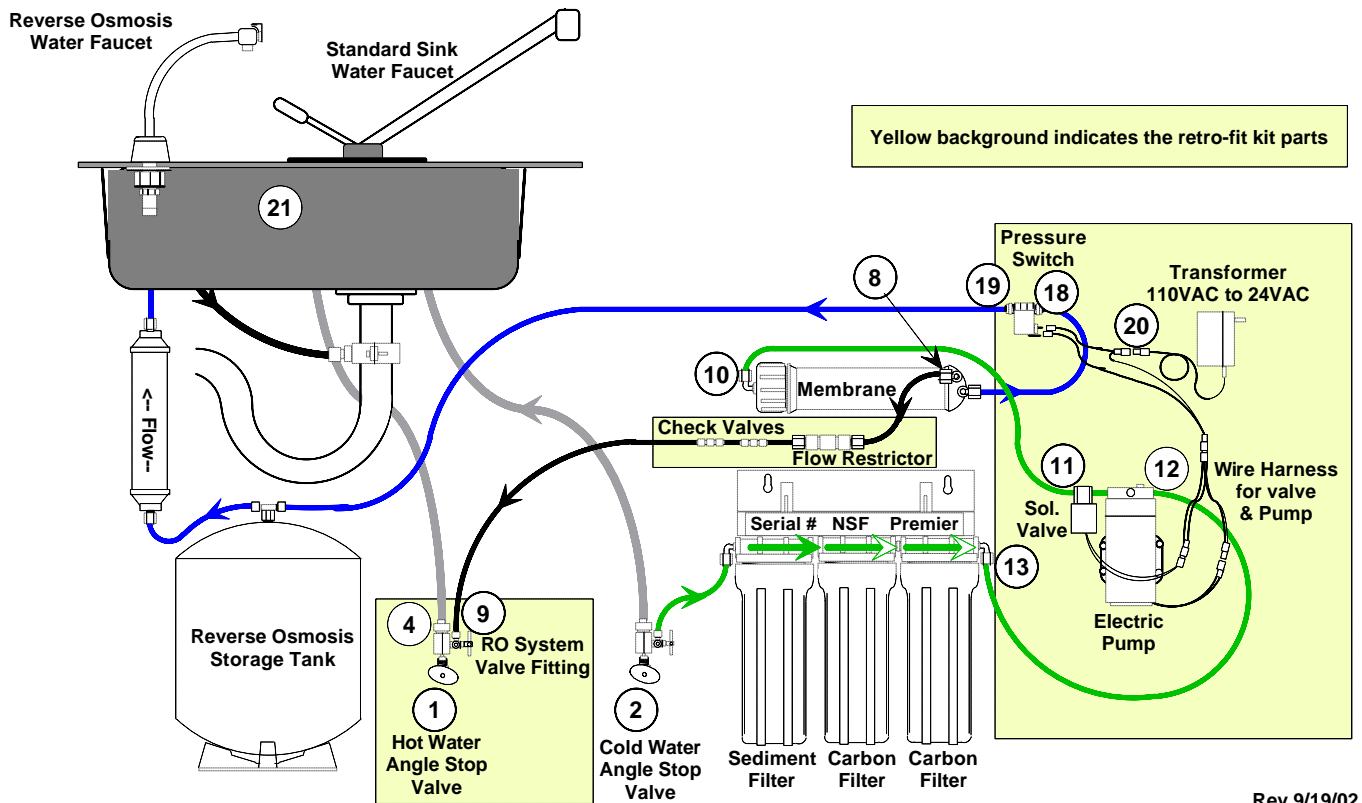

Figure 2 - Reverse Osmosis System with Zero Waste Kit Installed

Rev 9/19/02

Shut down procedure for filter and membrane maintenance

- Step 1 Turn off hot and cold water supply lines, (close ice maker valve if it applies).
- Step 2 Unplug the pump from electrical outlet.
- Step 3 Open RO faucet to drain tank, leave faucet open. If unit has a ball valve on tank close the ball valve and tank does not have to be emptied.
- Step 4 Follow normal maintenance procedures found in the original RO manual.
- Step 5 After maintenance is complete turn on hot and cold water supply.
- Step 6 Plug pump into electrical outlet.
- Step 6 Close RO faucet once water begins to trickle out.

Warranty

LIMITED WARRANTY: Watts Pure Water warrants each product to be free from defects in material and workmanship for a period of one year from the date of original shipment. In the event of such defects within the warranty period, the Company will, at its option, replace or recondition the product without charge. This shall constitute the sole and exclusive remedy for breach of warranty, and the Company shall not be responsible for any incidental, special or consequential damages, including, without limitation, lost profits or the cost of repairing or replacing other property which is damaged if this product does not work properly, other costs resulting from labor charges, delays, vandalism, negligence, fouling caused by foreign material, damage from adverse water conditions, chemicals, or any other circumstances over which the Company has no control. This warranty shall be invalidated by any abuse, misuse, misapplication or improper installation of the product. THIS WARRANTY IS IN LIEU OF ALL OTHER WARRANTIES, EXPRESS OR IMPLIED, INCLUDING ANY IMPLIED WARRANTIES OF MERCHANTABILITY OR FITNESS FOR A PARTICULAR PURPOSE. Any implied warranties that are imposed by law are limited in duration to one year.

Some States do not allow limitations on how long an implied warranty lasts, and some States do not allow the exclusion or limitation of incidental or consequential damages. Therefore, the above limitations may not apply to you. This Limited Warranty gives you specific legal rights, and you may have other rights that vary from State to State. You should consult applicable State laws to determine your rights.