

Quick Change Twin Manifolds

For use with Everpure quick-change cartridges



APPLICATIONS

| | |
|--------------|-------------|
| Fountain | Tea |
| Ice machines | Whole store |
| Coffee | |

FEATURES AND BENEFITS

Commercial-grade filter heads for Everpure filter cartridges.

Optional built-in water shut-off valve and flushing valve makes cartridge change-outs easy.

Cartridge nesting feature provides a more secure, durable fit.

Includes mounting box bracket and screws for fast and easy installation. No extra mounting plate is required.

Built-in water pressure gauge helps monitor proper flow.

All wetted parts have successfully passed NSF extraction tests.

Engineered for durability, strength and longevity. Will not corrode.

Includes EC110 or EC210 pre-filter cartridge and ScaleStick®.

OPERATIONAL TIPS

Change cartridges on a regular 6 month preventative maintenance program.

Change cartridges when capacity is reached or when pressure decreases.

Everpure water treatment systems (excluding replaceable elements) are covered by a limited warranty against defects in material and workmanship for a period of five years after date of purchase. Everpure replaceable elements (filter cartridges and water treatment cartridges) are covered by a limited warranty against defects in material and workmanship for a period of one year after date of purchase. See printed warranty for details. Everpure will provide a copy of the warranty upon request.



QC71 Twin Head: EV9272-22



Coldrink/Insurice Twin Manifold with 10" Prefilter: EV9293-02



High Flow CSR 10" Prefilter Twin Manifold: EV9294-02



Coldrink/Insurice Twin Manifold with 20" Prefilter: EV9293-22



High Flow CSR Twin Manifold with 20" Prefilter: EV9294-22

EC110 replacement cartridge: EV9534-12 (12 PK)

EC210 replacement cartridge: EV9534-26 (6 PK)

SPECIFICATIONS

| Dimensions: | Model | Dimensions |
|-------------|-------------------|---|
| | EV9272-22 | 16.6" W x 8.5" H x 6.13" D (42.16 x 21.59 x 15.57 cm) |
| | EV9293-02 | 21.59" W x 15.29" H x 6.13" D (54.84 x 38.83 x 15.57 cm) |
| | EV9293-22 | 21.59" W x 25.52" H x 6.13" D (54.84 x 64.82 x 15.57 cm) |
| | EV9294-02 | 25.58" W x 16.53" H x 6.94" D (64.97 x 41.98 x 17.63 cm) |
| | EV9294-22 | 25.58" W x 25.38" H x 6.94" D (64.97 x 64.46 x 17.63 cm) |
| | EV9534-12 (12 PK) | 9.8" H x 3.38" Ø D (24.90 x 8.58 Ø cm) |
| | EV9534-26 (6 PK) | 20" H x 3.38" Ø D (50.8 x 8.58 Ø cm) |

Electrical Connection: None

Quick Change Twin Manifolds

EV9272-22, EV9293-02, EV9293-22, EV9294-02, EV9294-22

INSTALLATION TIPS

Mounts directly onto flat surface. Install vertically so cartridge hangs down.

Allow 2½" clearance below the cartridge for easy cartridge replacement.

Flush filter by running water through filter according to cartridge instructions.

Refer to Installation, Operation & Maintenance Manual for cartridge flushing and start-up.

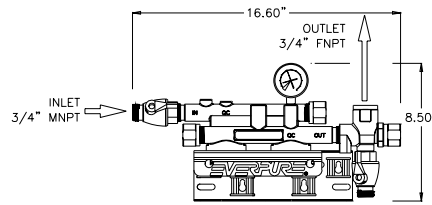

QC71 Twin Head: EV9272-22

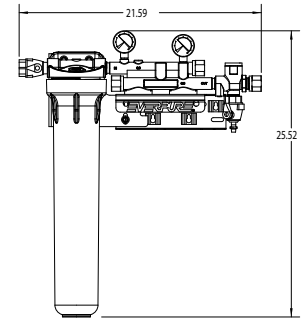

Coldrink/Insurice Twin Manifold with 20" Prefilter: EV9293-22

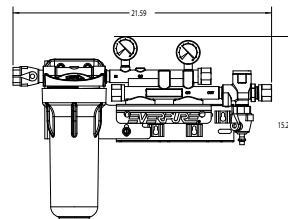

Coldrink/Insurice Twin Manifold with 10" Prefilter: EV9293-02

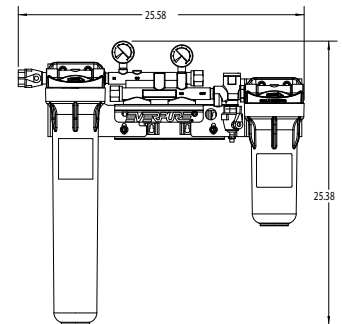

High Flow CSR Twin Manifold with 20" Prefilter: EV9294-22

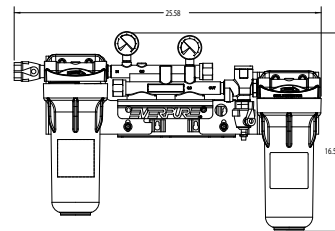

High Flow CSR Twin Manifold with 10" Prefilter: EV9294-02

Everpure reserves the right to update specifications, change prices, or make substitutions without notice.

QC-Single Manifolds MR11



Visit our website at www.everpure.com

Everpure-SHURflo India
Green Boulevard, B-9/A, 7th Floor -
Tower B Sector 62, Noida - 201301
TEL: 91.120.419.9444
FAX: 91.120.419.9400
EMAIL: indiacustomer@pentair.com

Everpure-SHURflo Japan Inc.
Hashimoto MN Bldg. 7F
3-25-1 Hashimoto, Midori-ku
Sagamihara-Shi Kanagawa 252-0143
JAPAN
TEL: 81.(0)42.775.3011
FAX: 81.(0)42.775.3015
EMAIL: info@everpure.co.jp

Everpure-SHURflo China
21F Cloud 9 Plaza, No 1118,
Shanghai, 200052
CHINA
TEL: 86.21.3211.4588
FAX: 86.21.3211.4580
EMAIL: China.Water@Pentair.com

Pentair Filtration Solutions, LLC
World Headquarters-Everpure/SHURflo
North and South America Sales
1040 Muirfield Dr.
Hanover Park, Illinois 60133
USA
TEL: 800.942.1153 (US only)
TEL: 630.307.3000
FAX: 630.307.3030
EMAIL: cseverpure@pentair.com

Everpure-SHURflo Australia
2 Redwood Drive
Notting Hill
Victoria, 3168
AUSTRALIA
TEL: 011.61.39.574.4000
FAX: 011.61.39.562.7237
EMAIL: au.everpure@pentair.com

Everpure-SHURflo Southeast Asia
18 Boon Lay Way
#04-110/111
TradeHub 21, 609966
SINGAPORE
TEL: 65.6795.2213
FAX: 65.6795.2219
EMAIL: cseverpure@pentair.com

Everpure-SHURflo Europe
Pentair Water Belgium bvba
Industriepark Wolfstee
Toekomstlaan
30 B-2200 Herentals, BELGIUM
TEL: +32.(0).14.283.500
FAX: +32.(0).14.283.505
EMAIL: sales@everpure-europe.com