

Aqua-Pure®

Models:

CS-S / LC / Complete

Drinking Water Systems

Spec # _____

Quantity _____

Applications:

- Chlorine Taste & Odor
- Sediment*
- Lead
- Parasitic Protozoan Cysts
- VOCs**

At a Glance:

- Easy to select the right product
- Easy to install, no special tools required
- Easy to maintain, filter change is a twist



Complete

CS-S

LC

Product Benefits:

- All systems reduce Chlorine Taste & Odor and Sediment helping provide better tasting water and cleaner ice cubes for your refrigerator
 - LC also reduces Lead and Parasitic Protozoan Cysts
 - Complete also reduces Lead, Parasitic Protozoan Cysts, VOCs**, Mercury, Turbidity and Asbestos
- Designed with built-in bypass valve – no need to shut off water for cartridge change
- Everything included for most installations

*Claims not tested or certified by NSF

**VOCs include: Lindane, Atrazine, Benzene, Carbofuran, 1,4-dichlorobenzene and Toxaphene

Product Specifications:

Model No. (Part No.)	Inlet/ Outlet Size	Dimensions		Flow Rate	Capacity	Max. Water Temp.	Max. Water Pressure	Std. Replacement Ctg. No.
		Height	Diameter					
CS-S (56179-05)	1/4" Push	10-1/2" (26.7 cm)	2-3/8" (6.0 cm)	0.75 gpm (2.8 lpm)	750 gallons (2,839 liters)	100°F (37.8°C)	125 psi (862 kPa)	C-CS-S (56180-09)
LC (56179-06)								C-LC (56180-11)
Complete (56179-04)		12-1/2" (31.8 cm)	C-Complete (56180-07)					

Aqua-Pure®

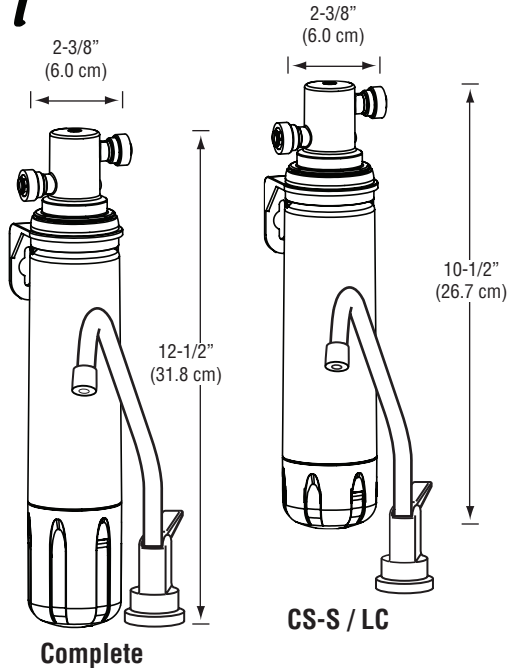

Spec # _____

Quantity _____

Model Number _____

Part Number _____

Physical Specifications:

- 1/4" Quick Connect fittings
- System is a single vessel design
- System is manufactured from FDA CFR-21 compliant materials
- System has a maximum operating pressure of 125 psi (862 kPa) and operating temperature of 100°F (37.8°C)
- System includes attached mounting bracket
- System includes dedicated faucet
- System to be installed on primary kitchen or bath cold water line

Easy Installation:

CAUTION: Diagram shown is for reference purposes only. Read installation and operation manual prior to installing the unit.

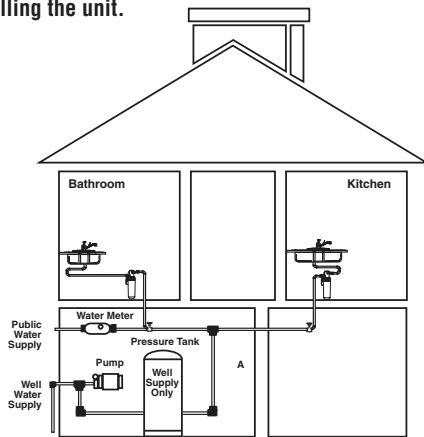

⚠WARNING: Do not use with water that is microbiologically unsafe or of unknown quality without adequate disinfection before or after the system. The contaminants or other substances removed or reduced by this water filter are not necessarily in all users water. Systems certified for cyst reduction may be used on disinfected water that may contain filterable cysts.

EPA Establishment Number 070595-CT-001

Aqua-Pure Model: Complete is pending Iowa certification.

CUNO Incorporated recommends regularly scheduled maintenance and replacement of the filter cartridge(s) in order for the product to perform as advertised/sold. **Change the filter cartridge at least every 6 months. Improper installation and maintenance may result in property damage due to water leakage.**

Limited Warranty:

CUNO Incorporated warrants this Product (excluding disposable filter cartridge(s)) to be free from defects in material and workmanship for one (1) year from the date of purchase. The disposable filter cartridge is warranted from defects in material and workmanship for a period of one (1) year from the date of purchase. This warranty does not cover failures resulting from abuse, misuse, alteration or damage not caused by CUNO or failure to follow installation and use instructions. If the Product is defective CUNO will replace the Product or refund your Product purchase price. CUNO will not be liable for any indirect, special, incidental, or consequential damages arising from the use of this Product. Some states do not allow the exclusion or limitation of incidental or consequential damages, so the above limitation may not apply to you. To obtain warranty service, mail your request to Warranty Claims, CUNO Incorporated, 400 Research Parkway, Meriden, CT 06450. Proof of purchase (original sales receipt) must accompany the warranty claim, along with a complete description of the Product, model number and alleged defect. This warranty gives you specific legal rights and you may have other rights which vary from state to state, or country to country.

Distributed by:

3M is a trademark of 3M Company.
 CUNO and Aqua-Pure are trademarks of 3M Company used under license.
 NSF is a trademark of NSF International.
 © 2009 3M Company. All rights reserved.
 LITAP884 0509
 70-0201-9313-5



Visit www.nsf.org for the claims associated with products that are NSF listed.



CUNO Incorporated
 400 Research Parkway
 Meriden, CT 06450 U.S.A.
 Toll Free: 1.800.222.7880
 Worldwide: 203.237.5541
 Fax: 203.238.8701
www.aquapure.com • www.cuno.com