

REVISIONS						
SHEET	ZONE	REV.	ECO	DESCRIPTION	DATE	APPROVED
1	ALL	A	50253	UPDATE DWG TO CURRENT FORMAT & STANDARDS	10/4/2018	HRC

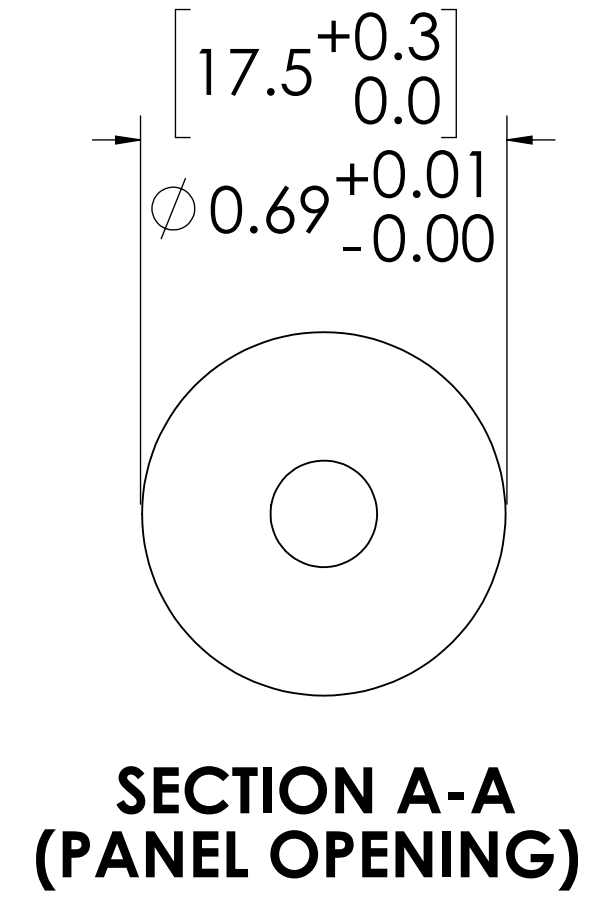
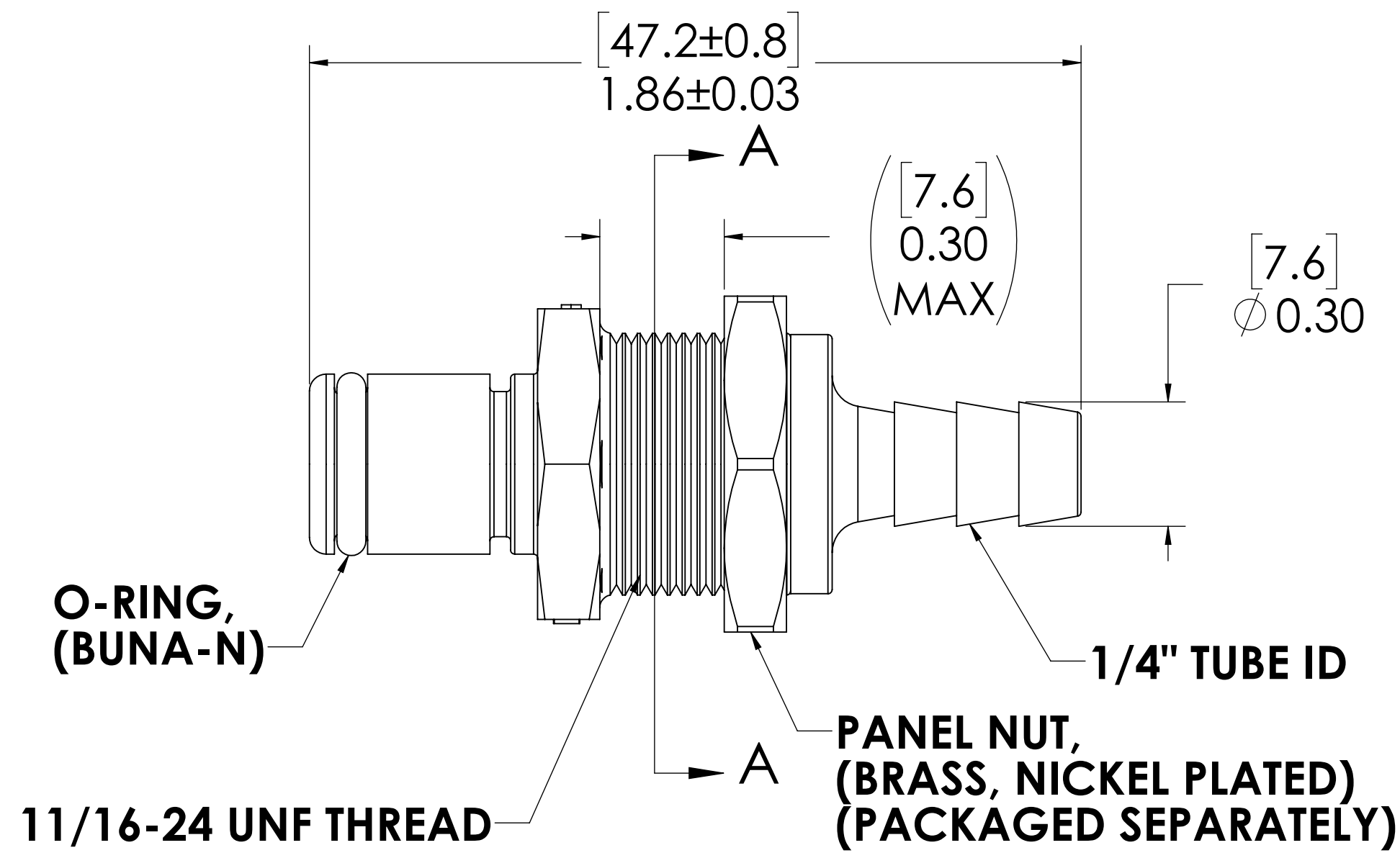
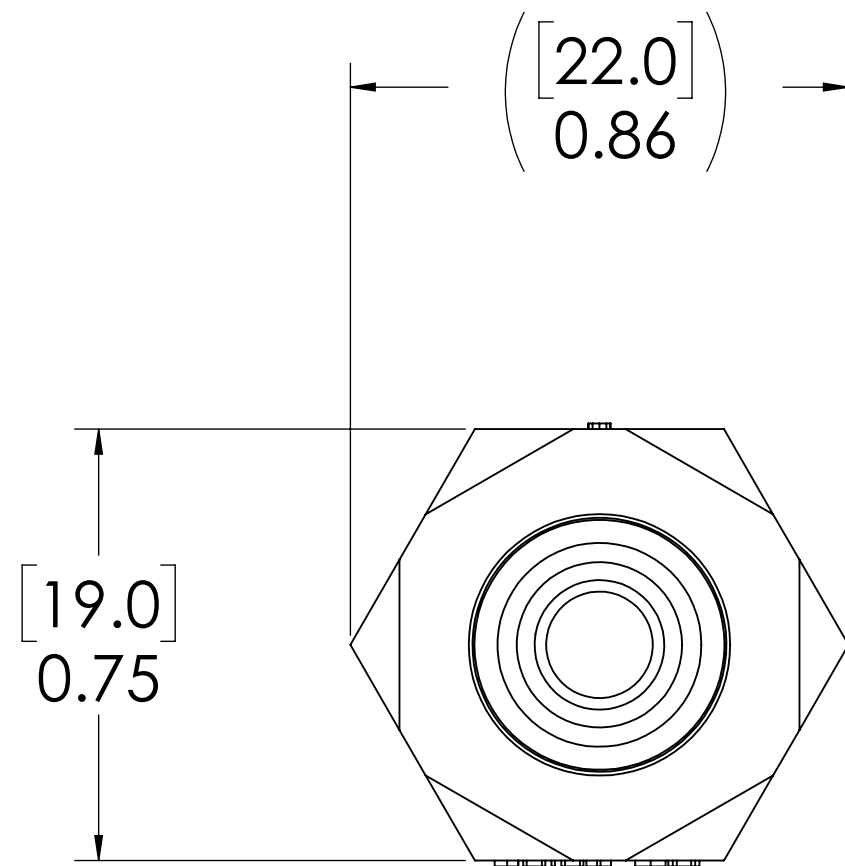
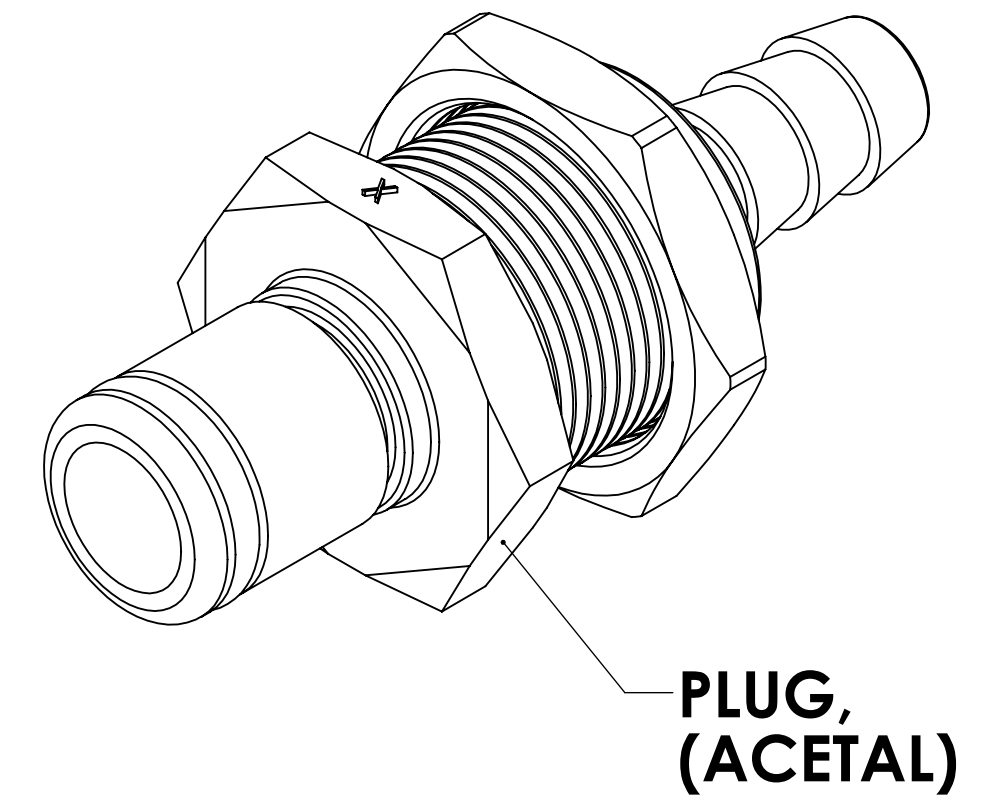

- NOTES:**
- MATERIAL: ACETAL
  - COLOR: NATURAL WHITE
  - O-RING MATERIAL: BUNA-N
  - O-RINGS LUBRICATED WITH FOOD GRADE SILICONE OIL, 350 CST.

**FOR REFERENCE ONLY**

<small>UNLESS OTHERWISE SPECIFIED:          DIMENSIONS ARE IN INCHES          TOLERANCES:          FRACTIONAL ± 1/32          ANGULAR, MACH ± 0.5 BEND ± 2          ONE PLACE DECIMAL ± 0.1          TWO PLACE DECIMAL ± 0.01          THREE PLACE DECIMAL ± 0.005          TWO PLACE DUAL (mm) [± 0.12]</small>	DRAWN	LDM	12/15/17	
	CHECKED	HRC	12/15/17	
	ENG APPR.	HRC	10/4/18	
	MFG APPR.	BDB	10/4/18	
PRODUCTION	LS	10/4/18		PART NO: <b>40AC-PB3-04</b> DESCRIPTION: <b>LinkTech 40AC Series Panel Mt. Male, Non-valved, 1/4" HB, Natural Acetal</b>
<small>PROPRIETARY AND CONFIDENTIAL          THE INFORMATION CONTAINED IN THIS DRAWING IS THE SOLE PROPERTY OF LINKTECH LLC. ANY REPRODUCTION OR DISCLOSURE IN PART OR AS A WHOLE WITHOUT THE WRITTEN PERMISSION OF LINKTECH LLC IS STRICTLY PROHIBITED.</small>	COMMENTS:			SIZE DWG. NO. REV <b>C 40AC400227 A</b>
	SCALE: NTS	WEIGHT:		SHEET 1 OF 1