

REVISIONS						
SHEET	ZONE	REV.	ECO	DESCRIPTION	DATE	APPROVED
1	ALL	A	50113	CONVERTED TO SOLIDWORKS	9/10/2014	HRC
1	E-2	A	50113	UPDATE NUT P/N FROM C324 TO C377	9/10/2014	HRC
1	ALL	B	50243	UPDATE DWG TO CURRENT FORMAT & STANDARDS	8/31/2017	HRC

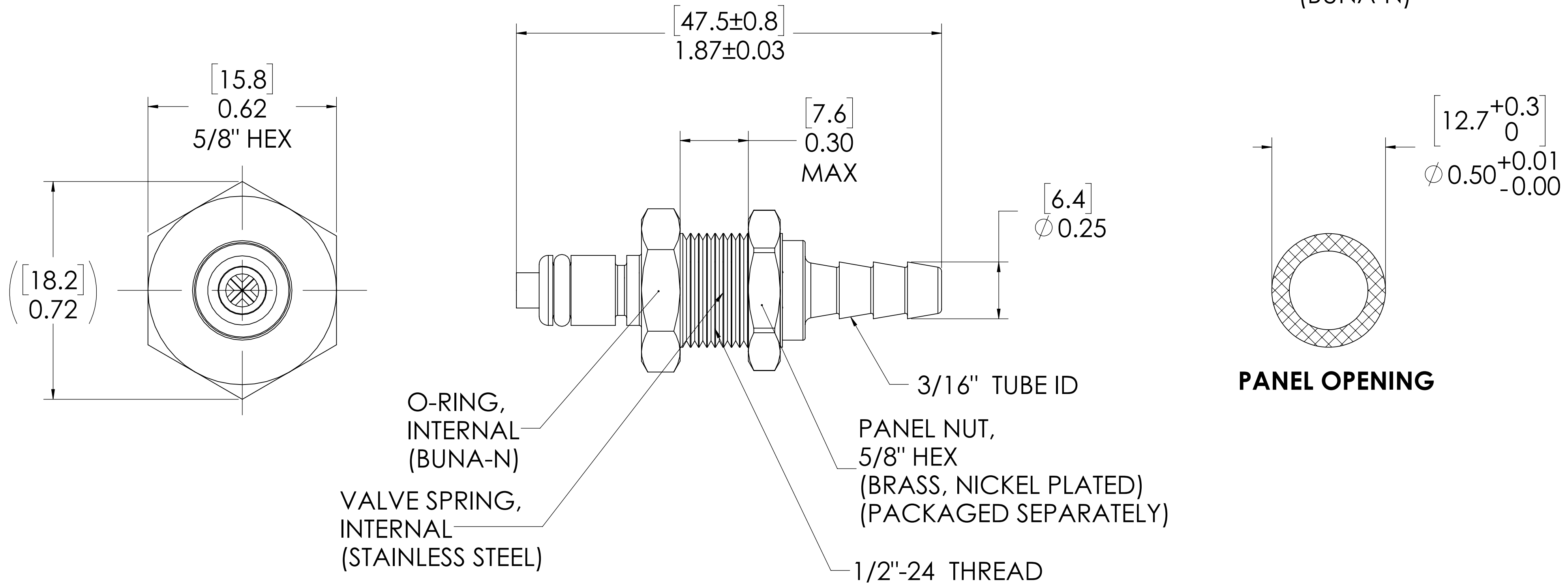
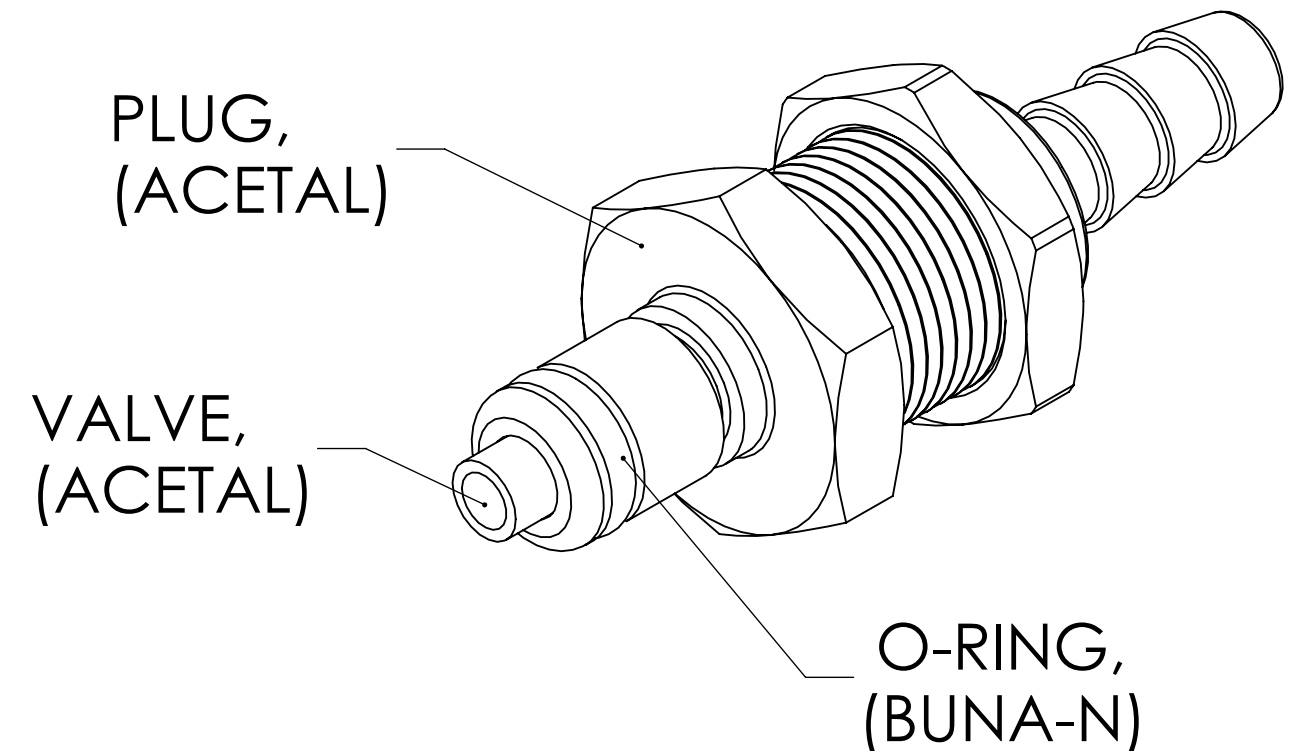

- NOTES:**
- MATERIAL: ACETAL
  - COLOR: NATURAL WHITE
  - O-RING MATERIAL: BUNA-N
  - O-RINGS LUBRICATED WITH FOOD GRADE SILICONE OIL, 350 CST.

**FOR REFERENCE ONLY**

<small>UNLESS OTHERWISE SPECIFIED:          DIMENSIONS ARE IN INCHES          TOLERANCES:          FRACTIONAL ±1/32          ANGULAR: MACH±0.5 BEND ±2          ONE PLACE DECIMAL ±0.1          TWO PLACE DECIMAL ±0.01          THREE PLACE DECIMAL ±0.005          TWO PLACE DUAL (mm) [±0.12]</small>	DRAWN	HRC	09-03-14	
	CHECKED			
	ENG APPR.	HRC	8/31/17	
	MFG APPR.	BDB	8/31/17	
<small>PROPRIETARY AND CONFIDENTIAL</small>	Q.A.	JJB	8/31/17	PART NO: 20ACV-PB3-03 DESCRIPTION: <b>LinkTech 20AC Series Panel Mt. Female, Valved, 3/16" HB, Natural Acetal</b>
<small>THE INFORMATION CONTAINED IN THIS DRAWING IS THE SOLE PROPERTY OF LINKTECH LLC. ANY REPRODUCTION OR DISCLOSURE IN PART OR AS A WHOLE WITHOUT THE WRITTEN PERMISSION OF LINKTECH LLC IS STRICTLY PROHIBITED.</small>	COMMENTS:			SIZE DWG. NO. REV <b>C 20AC200196 B</b>
				SCALE: NTS WEIGHT: SHEET 1 OF 1