

## DO NOT TURN THE WATER ON TO THE SYSTEM UNTIL INSTALLATION IS COMPLETE

When choosing a location to install the system, select an area with enough room for service to be performed on the system. Do not install the system in direct sunlight or subject the system to temperature extremes and/or excessive humidity.

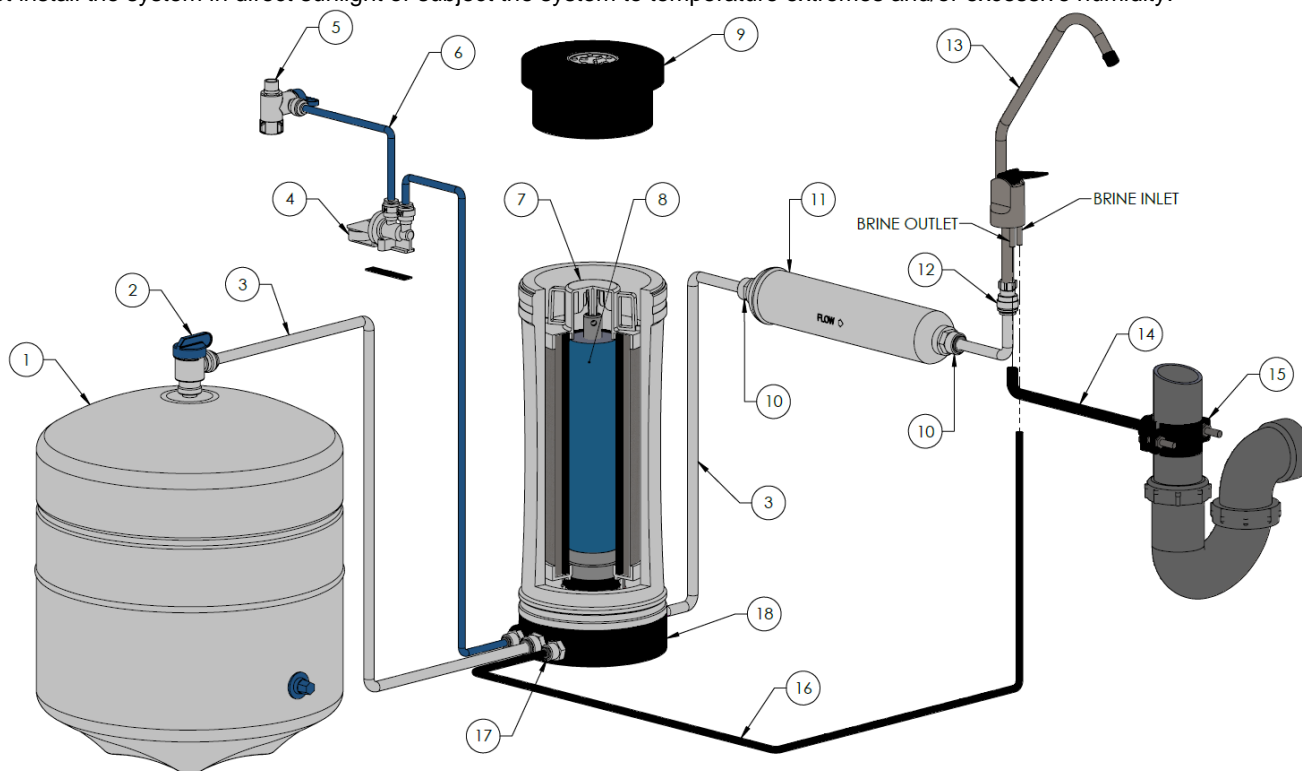

ITEM NUMBER	PART NUMBER	DESCRIPTION
1	200931	PERMEATE STORAGE TANK
2	211623	PERMEATE STORAGE TANK VALVE
3	201026	PRODUCT WATER LINE TO TANK AND FAUCET (3/8" WHITE TUBING)
4	207797	1/4" QUICK CONNECT LEAK DETECTOR
5	211478	1/4" QUICK CONNECT FEED WATER ADAPTOR (FOR 3/8" WATER SUPPLY LINE)
6	211663	FEED WATER LINE (1/4" BLUE TUBING)
7	211477	5 MICRON SEDIMENT AND SINTERED CARBON BLOCK PRE FILTER
8	211479	SOLO I REVERSE OSMOSIS MEMBRANE ELEMENT
9	211745	SOLO I REVERSE OSMOSIS SYSTEM LID
10	211481	3/8" QUICK CONNECT FITTING (1/4" MNPT THREAD)
11	200654	INLINE GRANULATED ACTIVATED CARBON POST FILTER
12	211482	3/8" QUICK CONNECT FAUCET ADAPTOR
13	207786	CHROME FAUCET WITH AIR GAP CONNECTION
14	201028	AIR GAP DRAIN LINE (3/8" BLACK TUBING)
15	211622	3/8" QUICK CONNECT DRAIN SADDLE
16	201018	SYSTEM DRAIN LINE FROM SYSTEM TO AIR GAP (1/4" BLACK TUBING)
17	200988	CONCENTRATE FLOW RESTRICTOR (INSTALLED INTO END OF TUBING)
18	211456	SOLO I REVERSE OSMOSIS SYSTEM

### Tools and Materials Required for Installation

- Variable speed drill
- Carbide grinding burr or file
- 1/4" drill bit (for making pilot holes)
- Tubing cutter
- 3/8" Drill bit
- 7/8" hole saw, or porcelain saw
- Adjustable wrench
- Tape measure
- Phillips screwdriver
- Teflon tape
- Protective eyewear

The above tools and materials are available at any local hardware stores. If you are uncomfortable performing the installation, please contact a local dealer or distributor for installation services

## 1. Feed Water Connection:

- 1.1. Locate the cold-water angle stop valve underneath the sink and turn it off.
- 1.2. Relieve the pressure by opening the cold-water line and disconnect the sink feed line.
- 1.3. Install the feedwater adapter (item 5) to the angle stop valve.
- 1.4. Insert the blue feed line tubing (item 6) into quick connect port of feed water adapter.
- 1.5. Connect the sink feed line to the feed water adapter. Make sure the feed water adapter is in the closed position and turn on the angle stop valve.

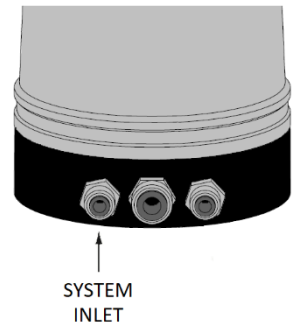
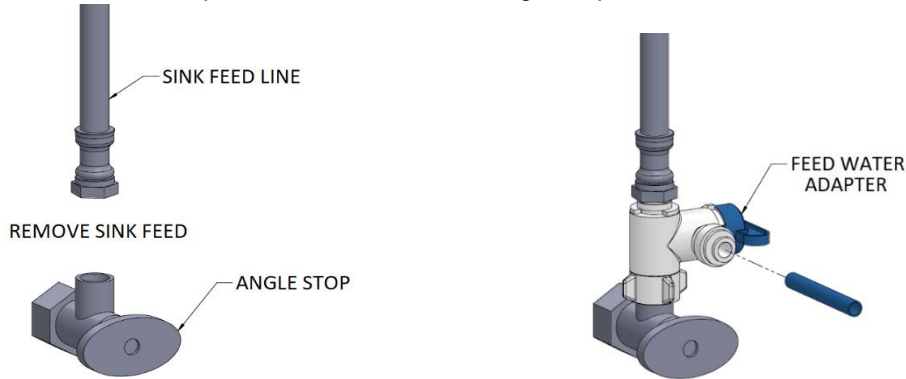

- 1.6. Connect the blue tubing (item 6) to the inlet of the leak detector (Item 4). Connect a section of blue tubing (item 6) from the leak detector outlet to the system inlet. Install the provided red locking clips.
- 1.7. Use the provided double sided tape to attach the leak detector (item 4) near the base of the system. Unwrap the provided compressed cloth and insert into the leak detector. Close the leak detector.

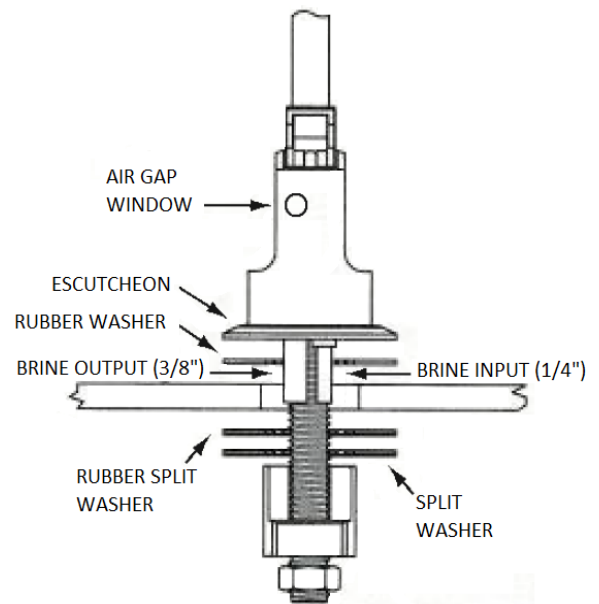
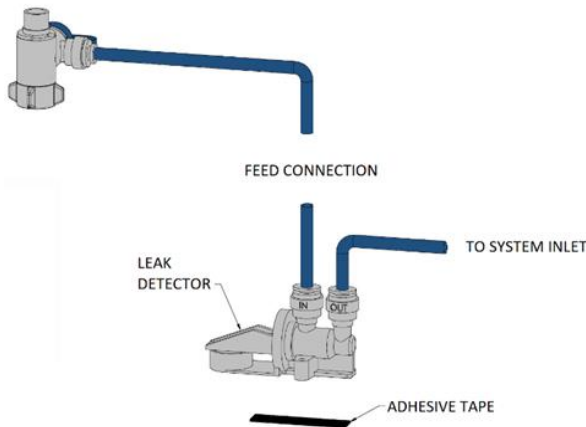
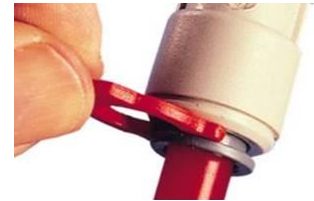

## 2. Faucet Installation: Installation of this Faucet requires a 7/8" opening in the sink or Countertop.

- 2.1. Install faucet (item 13) according to the diagram on the box or installation instructions provided on page 14 of the product manual.

## 3. Permeate (Product) Water Connection:

- 3.1. Apply Teflon tape to the threads of both 3/8" fittings (item 10) and install onto the inline filter.
- 3.2. Cut a section of white 3/8" tubing (item 3) approximately 18 to 36 inches and connect the water filter to the system inline filter connection. Use the remaining white 3/8" tubing to connect the inline filter (item 11) to the faucet (item 13) using the faucet adapter (item 12). Install the supplied red locking clips on the fittings.



- 3.3. Apply Teflon tape to the threaded stem on the top of the tank (item 1). Install the tank valve (item 2) to the top of the tank. Connect the tank valve to the system tank connection using the provided white 3/8" tubing (item 3). Install supplied red locking clips on the fittings.

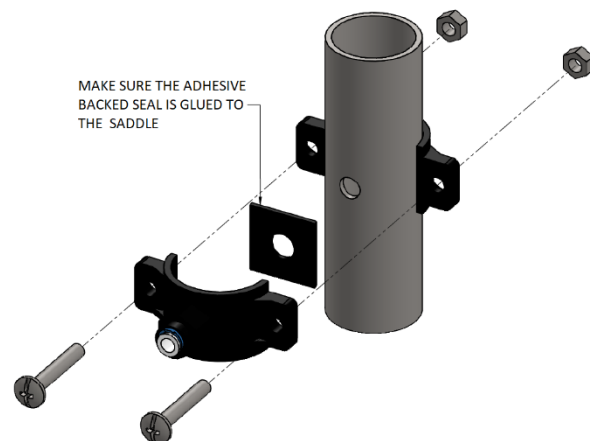
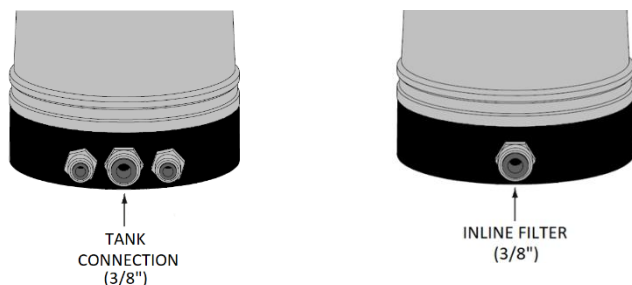

#### 4. Drain Saddle Installation:

- 4.1. Obtain the drain saddle assembly (item 15). Put the adhesive backed foam on the inside of the connection point of the drain saddle. Ensure the holes are aligned. Position the drain saddle on the sink drainpipe between the sink drain and the P trap.
- 4.2. Once in position, mark where the hole is to be drilled. Remove the drain saddle and drill the 3/8" hole into the drainpipe.
- 4.3. Align the drain saddle with the hole and secure it with the provided bolts.

#### 5. Air Gap Connection:

- 5.1. Insert the black 3/8" tubing (item 14) into the drain saddle and press the other end onto the large (brine outlet) barb on the faucet air gap. Ensure there are no dips or low points in the tubing from the faucet to the drain saddle. Trim accordingly.
- 5.2. Obtain the black 1/4" tubing (item 16) and measure the length required to connect the system outlet to the brine inlet on the faucet air gap.
- 5.3. Install the provided capillary flow restrictor (item 17) into the open end of the tubing.
- 5.4. Firmly press the tubing into the drain port of the system. Press the opposite end onto the brine inlet of the faucet air gap.

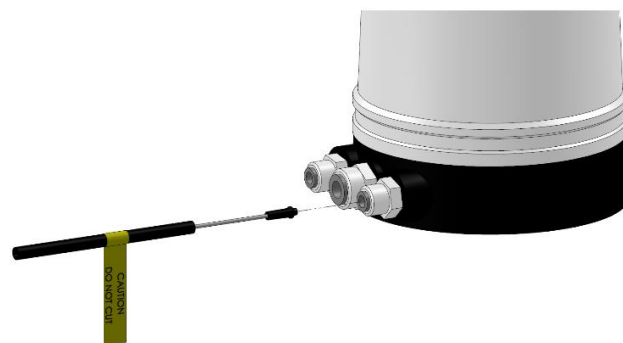

#### 6. Membrane Installation and Initial Start Up:

- 6.1. Use the provided wrench to remove the black cap (item 9) to the system. Remove the 2-stage (item 7) filter from the system and remove the plastic film wrap.
- 6.2. Obtain the membrane (item 8) and remove it from its packaging. Insert the membrane down into the filter cartridge while twisting (O-Rings up as shown). Ensure the membrane is fully inserted into the filter.
- 6.3. Place the filter and membrane into the system base.
- 6.4. Replace the system cap and tighten with the provided wrench. Note the installation date on the calendar wheel.
- 6.5. Double check that all connections are made, and the tubing is in securely. Make sure the tank valve is open. Make sure the lever on the leak detector is in the down position. Flip the Faucet lever up to allow for continuous flow.
- 6.6. Slowly turn the feed valve 1/4 turn, observe for any leaks.
- 6.7. Allow the system to drain the permeate for the first hour of operation. Once complete, flip the faucet lever down.
- 6.8. Please allow for the tank to fill 3-4 times before drinking the product water. After completely draining the tank 3-4 times you may begin to use the water for consumption.

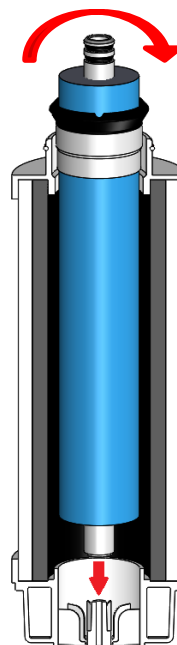

**MEMBRANE INSERTED COMPLETELY**

