



EVERPURE® QC7I TRIPLE-XCLM⁺ HIGH CAPACITY CHLORAMINES REDUCTION SYSTEM

HIGH CAPACITY QUICK-CHANGE CHLORAMINES REDUCTION SYSTEM FOR FOUNTAIN APPLICATIONS

QC7I Triple-XCLM⁺ System: EV9761-13
Replacement cartridge: EV9761-00



APPLICATIONS

Fountain

FEATURES • BENEFITS

A specialized carbon formulation maximizes the volume of activated carbon to provide a combination of optimal chloramines reduction with improved product life in a single cartridge

Reduces chloramines, chlorine taste & odor and other offensive contaminants that can adversely affect the taste of beverages

Superior filtration provides enhanced chlorine taste & odor reduction and filters dirt and particles as small as 5 microns in size

Sanitary cartridge replacement is simple, quick and clean. Internal filter parts are never exposed to handling or contamination

NSF/ANSI Standard 42 certified

INSTALLATION TIPS

Install vertically on flat surface with cartridges hanging down.

Allow 2½" (6.35 cm) clearance below the cartridges for easy cartridge replacement.

Flush cartridges by running water through filter according to cartridge instructions.

Refer to Installation and Operation Guide for cartridge flushing and start-up.

OPERATION TIPS

Change cartridges on a regular one (1) year preventative maintenance program.

Change cartridges when capacity is reached or when pressure decreases.

SIZING

Rated Capacity at Service Flow Rate:

27,900 gallons @ 6.00 gpm
(105,612 L @ 22.71 Lpm)

34,800 gallons @ 5.01 gpm*
(131,732 L @ 18.96 Lpm*)

57,900 gallons @ 3.00 gpm*
(219,175 L @ 18.96 Lpm*)

* Not Performance Tested or Certified by NSF.

EVERPURE® QC71 TRIPLE-XCLM+ HIGH CAPACITY CHLORAMINES REDUCTION SYSTEM

EV9761-13

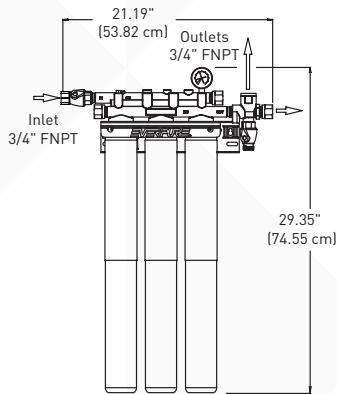

SPECIFICATIONS

Overall Dimensions

21.19 W x 5.8" D x 29.35" H
(53.82 cm x 13.5 cm x 74.55 cm)

Rated Capacity

27,900 gallons @ 6.00 gpm
(105,612 L @ 22.71 Lpm)

34,800 gallons @ 5.01 gpm*
(131,732 L @ 18.96 Lpm*)

57,900 gallons @ 3.00 gpm*
(219,175 L @ 11.35 Lpm*)

* Not Performance Tested
or Certified by NSF.

Pressure Requirements

10 - 125 psi (0.7 - 8.6 bar), non-shock

Temperature

35 - 100°F (2 - 38°C)

Electrical Connection

None required



System is Tested and Certified by NSF International against NSF/ANSI Standard 42 for the reduction of:
STANDARD NO. 42 —
AESTHETIC EFFECTS

Chemical Reduction
Taste and Odor
Chloramines
Chlorine

Mechanical Filtration
Nominal Particulate Reduction:
Class III

The contaminants or other substances removed or reduced by this drinking water system are not necessarily in your water. Do not use with water that is microbiologically unsafe or of unknown quality without adequate disinfection before or after the system.

WARRANTY

Everpure water treatment systems by Pentair® (excluding replaceable elements) are covered by a limited warranty against defects in material and workmanship for a period of five years after date of purchase. Everpure replaceable elements (filter cartridges and water treatment cartridges) are covered by a limited warranty against defects in material and workmanship for a period of one year after date of purchase. See printed warranty for details. Pentair will provide a copy of the warranty upon request.



WATER QUALITY SYSTEMS

EVERPURE-SHURFLO WORLD HEADQUARTERS, 1040 MUIRFIELD DRIVE, HANOVER PARK, IL 60133 USA • FOODSERVICE.PENTAIR.COM
800.942.1153 (US ONLY) • 630.307.3000 MAIN • 630.307.3030 FAX • CSEVERPURE@PENTAIR.COM EMAIL

EVERPURE-SHURFLO AUSTRALIA, 1-21 MONASH DRIVE, DANDENONG SOUTH, VIC 3175 AUSTRALIA
011.1300.576.190 TEL • 011.61.39.562.7237 FAX • AU.EVERPURE@PENTAIR.COM EMAIL

EVERPURE-SHURFLO CHINA, 21F CLOUD 9 PLAZA, NO 1118, SHANGHAI, 200052, CHINA
86.21.3211.4588 TEL • 86.21.3211.4580 FAX • CHINA.WATER@PENTAIR.COM EMAIL

EVERPURE-SHURFLO INDIA, GREEN BOULEVARD, B-9/A, 7TH FLOOR - TOWER B SECTOR 62, NOIDA - 201301
91.120.419.9444 TEL • 91.120.419.9400 FAX • INDIACUSTOMER@PENTAIR.COM EMAIL

EVERPURE-SHURFLO EUROPE, PENTAIR WATER BELGIUM BVBA, INDUSTRIEPARK WOLFSTEE, TOEKOMSTLAAN 30, B-2200 HERENTALS, BELGIUM
+32.(0).14.283.504 TEL • +32.(0).14.283.505 FAX • SALES@EVERPURE-EUROPE.COM EMAIL

EVERPURE-SHURFLO JAPAN INC., HASHIMOTO MN BLDG. 7F, 3-25-1 HASHIMOTO, MIDORI-KU, SAGAMIHARA-SHI KANAGAWA 252-0143, JAPAN
81.(0)42.775.3011 TEL • 81.(0)42.775.3015 FAX • INFO@EVERPURE.CO.JP EMAIL

EVERPURE-SHURFLO SOUTHEAST ASIA, 390 HAVELOCK ROAD, #04-01 KING'S CENTRE, SINGAPORE 169662
65.6768.5800 TEL • 65.6737.5149 FAX • CSEVERPURE@PENTAIR.COM EMAIL

All Pentair trademarks and logos are owned by Pentair, Inc. or its affiliates. All other registered and unregistered trademarks and logos are the property of their respective owners. Because we are continuously improving our products and services, Pentair reserves the right to change specifications without prior notice. Pentair is an equal opportunity employer.