



Installation and Operation Guide

HFC-10 Deliming System for Ware Washing Equipment

Provides simple, efficient deliming of commercial ware washing equipment, utilizing ScaleKleen™, Everpure's proprietary scale remover.

BENEFITS

- Permanently plumbed in the hot water feed line before booster heater and dishwasher.
- Drastically reduces maintenance teardowns due to limescale accumulation.
- Assures high efficiency of heating elements by removing limescale deposits.
- Utilizes Everpure's proprietary foodgrade delimer ScaleKleen™ — no offensive odors, no burned skin or clothing, environmentally safe.
- High grade re-enforced nylon components for long life.
- Extends life of equipment.

APPLICATIONS

- Flash steamers
- Conventional steamers
- Combi-ovens
- Coffee/espresso machines

DEMLIMING SCHEDULE			
Dishwasher Operation (Hours)			
Water Hardness	2-8	8-14	14-20
Soft, 0-3 gpg	30 days	24 days	18 days
Moderately Hard, 3-7 gpg	24 days	18 days	12 days
Very Hard, > 15 gpg	9 days	6 days	3 days

To determine water hardness and frequency of delimiting, follow instructions on hardness test strip package and compare to hours of operation.

SPECIFICATIONS

Dimensions: 12½"L x 5½"W x 5½"D
(allow extra 4" underneath for shell removal)

Inlet connection: 1/2" MPT

Pressure (Minimum - Maximum): 10 - 125 psi (non-shock)

Maximum temperature: 160°F

Shipping weight: 5 lbs.

Operating weight: 7 lbs.

INSTALLATION

Note: System must be installed on inlet water line to equipment. Everpure recommends the installation of a by-pass for de-limiting.

1. Turn off power to equipment and drain water from system, if necessary.
2. Provide appropriate tee connections for inlet and outlet connections. Refer to the diagram at right.
3. Install a bypass valve (buyer provided) between the inlet and outlet connections. Refer to the diagram at right.
4. Install ball valves to inlet and outlet connections on the HFC-10 head assembly.
NOTE: Always use a good grade of pipe dope or teflon tape on connections.
5. Make appropriate connections to ball valves.



System Part No. EV9100-91

Includes:

- (1) 2.2 lb. Scalekleen package
- (1) Diptube assembly
- (1) Hardness Test Strip

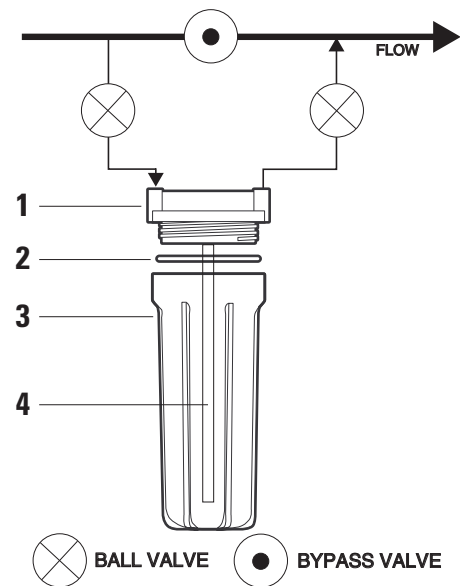

SPARE PARTS:	
1.	EV3095-02: Head Assembly
2.	EV3095-04: Gasket
3.	EV3095-03: Sump Assembly
4.	EV3093-35: Dip Tube
	EV3095-44: Bracket Kit (bracket, nut, mtg. screws)
	EV9796-01: ScaleKleen 2.2 lb. pkg. (4 pack)
	EV3024-94: Hardness Test Strip

USING SCALEKLEEN™

1. Turn off power to equipment and disconnect automatic soap dispenser, if installed.
2. Make sure both inlet and outlet valves on HFC-10 are in the closed position.
3. Close the bypass valve.
4. Remove the HFC-10 housing.
5. Pour (1) 2.2 lb. package of ScaleKleen™ into the HFC-10 and reassemble the housing to the HFC-10 head.

NOTE: Make sure the gasket is in place.

6. Slowly open the inlet and outlet valves, keeping the bypass valve in the closed position.
7. Turn the power on and run machine at full operating temperature for 20 minutes.
8. After 20 minutes, turn the power off and drain the machine. Reconnect the automatic soap dispenser.
9. Close both the inlet and outlet valves on the HFC-10 head.
10. Open the bypass valve.

LIMITED WARRANTY

Commercial Water Treatment Equipment

You have just purchased one of the finest water treatment units made. As an expression of our confidence in Everpure products, this product is warranted against defects in material and workmanship to the original end-user when installed in accordance with Everpure specifications. The warranty period commences from the date of purchase and is administered as follows:

For a period of ONE YEAR

Replaceable elements (i.e., filter & water treatment cartridges)*

For a period of FIVE YEARS

The entire system (excluding replaceable elements)

***This is for material & workmanship, not filter or water treatment cartridge life.**

The unit must be used in operating conditions that conform to Everpure's recommended design guidelines. This warranty will not apply if the unit has been modified, repaired or altered by someone not authorized by Everpure.

If a part described above is found defective within the specified period, you should notify Everpure technical service at the phone number listed below. Any part found defective within the terms of this warranty will be repaired or replaced (at Everpure's discretion) by your local dealer or Everpure technical service. You pay only freight from our factory and local dealer charges. Any repaired or replaced warranty item will be incorporated under the original warranty terms of the existing system.

We are not responsible for damage caused by accident, fire, flood, freezing, Act of God, misuse, misapplication, neglect, oxidizing agents (such as chlorine, ozone, chloramines and other related components), alteration, installation or operation contrary to our printed instructions, or by the use of accessories or components which do not meet Everpure's specifications. Refer to the specifications section in the Installation and Operating manual for approved application parameters.

Our product performance specifications are furnished with each water treatment unit. TO THE EXTENT PERMITTED BY LAW, EVERPURE DISCLAIMS ALL IMPLIED WARRANTIES, INCLUDING WITHOUT LIMITATION WARRANTIES OF MERCHANTABILITY AND FITNESS FOR PARTICULAR PURPOSE; TO THE EXTENT REQUIRED BY LAW, ANY SUCH IMPLIED WARRANTIES ARE LIMITED IN DURATION TO THE PERIOD SPECIFIED ABOVE FOR THE ENTIRE WATER TREATMENT UNIT. As a manufacturer, we do not know the characteristics of your water supply or the purpose for which you are purchasing this product. The quality of water supplies may vary seasonally or over a period of time, and your water usage rate may vary as well. Water characteristics can also differ considerably if this product is moved to a new location. For these reasons, we assume no liability for the determination of the proper equipment necessary to meet your requirements, and we do not authorize others to assume such obligations for us. Further, we assume no liability and extend no warranties, express or implied, for the use of this product with a non-potable water source or a water source which does not meet the conditions for use described in the owner's guide or performance data sheet for this product. OUR OBLIGATIONS UNDER THIS WARRANTY ARE LIMITED TO THE REPAIR OR REPLACEMENT (AT EVERPURE'S DISCRETION) OF THE FAILED PARTS OF THE WATER TREATMENT UNIT, AND WE ASSUME NO LIABILITY WHATSOEVER FOR DIRECT, INDIRECT, INCIDENTAL, CONSEQUENTIAL, SPECIAL, GENERAL OR OTHER DAMAGES.

Some states do not allow the exclusion of implied warranties or limitations on how long an implied warranty lasts, so the above limitation may not apply to you. Similarly, some states do not allow the exclusion of incidental or consequential damages, so the above limitation or exclusion may not apply to you. This warranty gives you specific legal rights, and you may also have other rights which vary from state to state. Consult your telephone directory for your local independently operated Everpure dealer, or write Everpure for warranty and service information.



For sales, replacement components, and service, contact your Everpure dealer or:

Everpure, Inc.: 1040 Muirfield Drive • Hanover Park, Illinois 60133 • 800.323.7873

Everpure Europe NV, Toekomstlaan 30, B-2200 Herentals, Belgium

Everpure, Japan, Inc., Hashimoto MN Bldg. 7F, 3-25-1 Hashimoto Sagamihara-Shi, Kanagawa 229-1103, Japan

Technical Service

800.942.1153

www.everpure.com