



## Snapshot

The SCLX2-1 is a 10" Drop-In cartridge that utilizes ScaleX2®, a chemical-free scale inhibition technology that utilizes template-induced crystallization to effectively inhibit the formation of calcium-carbonate scale. This cartridge is ideal for applications requiring up to 1.5 gpm flow.

## Cartridge Benefits

- ScaleX2® achieved a 99.6% effectiveness rating when tested by an independent laboratory against the international protocol for scale prevention.
- Reduces maintenance frequency and cost, and extends equipment life.
- Protects boilers, steam generators and coffee equipment against the formation and accumulation of calcium-carbonate scale.
- Generates less waste, only the drop-in cartridge is replaced. No discarding of metal or plastic quick-change filters.
- Replacement cartridge cost-per-gallon is much less than proprietary quick-change filters.
- NSF Certified under Standard 42 as replacement cartridge in OptiPure SX2 Series Systems.

Model: **SCLX2-1**  
Part #: 252-60205

### REPLACEMENT CARTRIDGE

ITEM #: \_\_\_\_\_ QTY: \_\_\_\_\_

JOB NAME/NUMBER \_\_\_\_\_



## Application

### Boiler-Based Steam Generators

Drop-In style cartridge for OptiPure SX2 Systems.

## Installation Tips

- Insure cartridge is designed to replace the existing cartridge.
- Do not exceed cartridge specifications for temperature and pressure.
- Allow 3" clearance below system for filter cartridge removal and replacement.
- No activation procedure or flushing is required for cartridge to perform as specified.
- Feed-water connection to system should be COLD only.



Model: **SCLX2-1**  
Part #: 252-60205

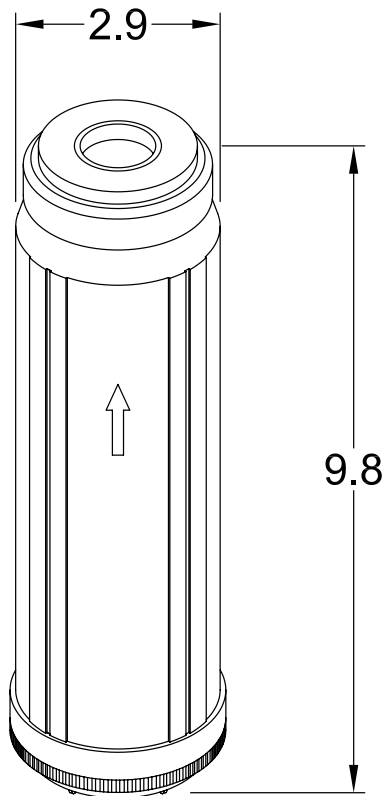

Replacement Element is tested and certified by NSF International against NSF/ANSI Standard 42 for material requirements only.



**WARNING:**  
Cancer and Reproductive Harm -  
[www.P65Warnings.ca.gov](http://www.P65Warnings.ca.gov).

## ► Warranty

Replacement filter cartridges are warranted for defects in material and workmanship only. Service life of replacement filter cartridges varies significantly with local water conditions and volume and thus cannot be warranted. Furthermore, separation membranes are equally susceptible to feed water conditions (e.g. presence of iron, alum and silica) and shall be warranted only for defects in construction. Membrane failure due to fouling, hydrolysis, oxidation or other damage caused by the local water conditions is not covered under warranty. For complete warranty information, contact OptiPure customer service or go to [www.optipurewater.com](http://www.optipurewater.com).

Dealer/Distributor Info:

## ► Specifications

Cartridge	
Dimensions (Height x Width x Depth, Inches)	9.8" h x 2.9" w x 2.9" d
Operating Pressure Range	10 - 125 psi (0.7 - 8.6 bar)
Inlet Water Temperature Range	35° - 100°F (2° - 38°C)
Performance	
Chlorine, Taste and Odor Reduction Capacity	N/A
Service Flow Rate	1.5 gpm (5.7 lpm)
Sediment Reduction	N/A
Scale & Corrosion Inhibitor	ScaleX2®

## ► System(s) Cartridge Used In

Model	Part Number	Qty
SX2-11	160-50131	1
SX2-21	160-00350	1

It is recommended that pre/post-filters and mineral addition cartridges are changed every 6 months, when capacity is reached or when feedwater pressure or flow becomes inadequate.

Membrane life varies depending on feedwater conditions and pre-filter maintenance. It is 12-18 months under typical conditions, but it can be as long as 3-5 years.

This product is for commercial use only and must be installed and maintained according to manufacturer's guidelines.

Do not use on water that is microbiologically unsafe or of unknown quality without adequate disinfection before or after the system.

## OptiPure, A Division of Aquion, Inc.

101 S. Gary Ave., Suite A  
Roselle, IL 60172

p: 972.881.9797 e: [info@optipure.net](mailto:info@optipure.net)  
[www.optipurewater.com](http://www.optipurewater.com)