



EV9797-20

# SR-X Feeder/Deliming System

Superior scale prevention and corrosion control for steam equipment



SR-X Feeder and Deliming System: EV9797-20

SS-10 Cartridge: EV9799-02

2.2 lb package ScaleKleen and Dip Tube

## BENEFITS

A complete system that effectively targets scale

Provides protection against equipment corrosion

A sophisticated blend of polyphosphate compound represents an advancement in scale inhibition

Patented design (patent no. 5,580,448) dispenses a controlled amount of Hydroblend™ for long-term protection and provides greater effectiveness than standard phosphate treatments

SS-10 cartridge is more effective in higher alkalinity/ hardness/ TDS/ temperature installations.

Clear bowl and cartridge make it easy to determine when Hydroblend compound is exhausted

System includes clear SR-X housing, SS-10 cartridge, dip tube assembly, (1) 2.2 lb. ScaleKleen package

The SS-10 is NSF Certified under NSF/ANSI Standard 42 for material requirements only

## INSTALLATION TIPS

Choose a mounting location suitable to support the full weight of the system when operating

Make sure to properly lubricate O-ring prior to use

Use 3/4" water line (Optional reducer bushings included)

Install vertically with bowl hanging down

Allow 2-1/2" clearance below the cartridge for easy cartridge replacement

For steam applications, connect the system to the boiler water only! Do not connect to the condenser!

## OPERATION TIPS

Deliming of equipment prior to application is recommended, but not required

Inspect SS-10 cartridge at least every 6 months

Replace SS-10 cartridge before Hydroblend™ compound is completely dissolved

Pre-existing equipment scale may come loose and clog equipment. Remove any loose scale to assure satisfactory operation

## APPLICATION/SIZING

For scale reduction applications

Provides scale reduction for steam applications

Provides delimiting capabilities

# SR-X Feeder/Delimiting System

## SPECIFICATIONS

Overall Dimensions:  
12.44"H x 5.16"W x 5.5"D

Inlet connection: 3/4"

Outlet connection: 3/4"

Service Flow Rate:  
Maximum 6.0 gpm (22.7 Lpm)

Pressure Requirements:  
10 - 125 psi (0.7 - 8.6 bar), non-shock

Temperature: 35 - 100°F (2 - 38°C)

No electrical connection required

Shipping Weight: 6 lbs.

Operating Weight: 6 lbs.

\*\*The ScaleStick® trademark is used pursuant to an agreement between PWC Enterprises and Everpure, Inc.

The contaminants or other substances removed or reduced by this drinking water system are not necessarily in your water. Do not use with water that is microbiologically unsafe or of unknown quality without adequate disinfection before or after the system. Systems certified for cyst reduction may be used with disinfected water that may contain filterable cysts.

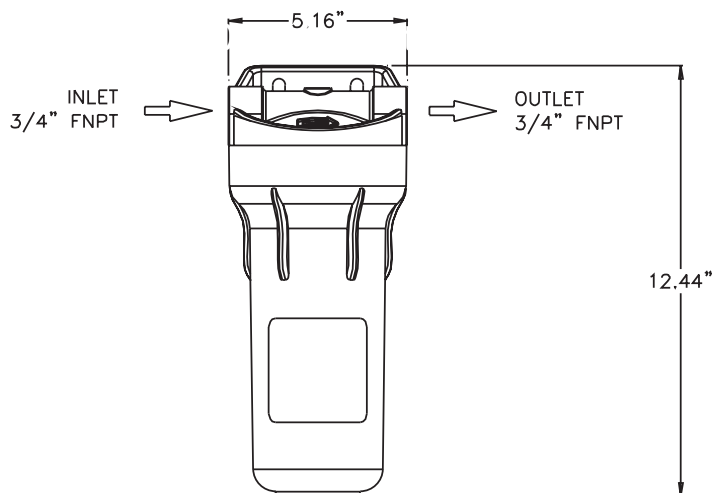

## WARRANTY

Everpure water treatment systems (excluding replaceable elements) are covered by a limited warranty against defects in material and workmanship for a period of five years after date of purchase. Everpure replaceable elements (filter cartridges and water treatment cartridges) are covered by a limited warranty against defects in material and workmanship for a period of one year after date of purchase. See printed warranty for details. Everpure will provide a copy of the warranty upon request.

### EVERPURE®

EVERPURE, LLC  
1040 Muirfield Drive  
Hanover Park, Illinois 60133  
Toll Free (800) 323-7873  
Tel (630) 307-3000  
Fax (630) 307-3030  
<http://www.everpure.com>

*In Europe:*  
N.V. EVERPURE (EUROPE) S.A.  
INDUSTRIEPARK WOLFSTEE  
TOEKOMSTLAAN 30  
B-2200 HERENTALS  
BELGIUM  
TEL 32 -14-283500  
FAX 32-14-283505

*In Japan:*  
EVERPURE JAPAN LLC  
HASHIMOTO MN BLDG. 7F  
3-25-1 HASHIMOTO SAGAMIHARA-SHI  
KANAGAWA 229-1103  
JAPAN  
TEL 81-(0)42-775-3011  
FAX 81-(0)42-775-3015

Everpure  
1040 Muirfield Drive  
Hanover Park, IL 60133  
Phone: 630-307-3020 Fax: 630-307-3030