

# SteamerGUARD 12000

with NanoCRYSTAL Technology

System Part: #63-1620  
Replacement Cartridge: #101-620

**STEAMER APPLICATION**  
FOR OPEN SYSTEMS W/DUMP CYCLE

**FOR:** Hardness/Scale,  
Chlorine, Reduction

**VOLUME:** High

## SPECIFICATIONS:

- Rated Capacity (Gallons): 12,000
- Flow Rate: 2 gpm
- Min/Max Pressure: 40–125 psi.
- Min/Max Temperature: 40°–100° F
- Inlet/Outlet Size: 1/2 Inch Barbed Fitting
- Shipping Weight: 25 lbs.
- System Dimensions (W/D/H): 17/9/28”

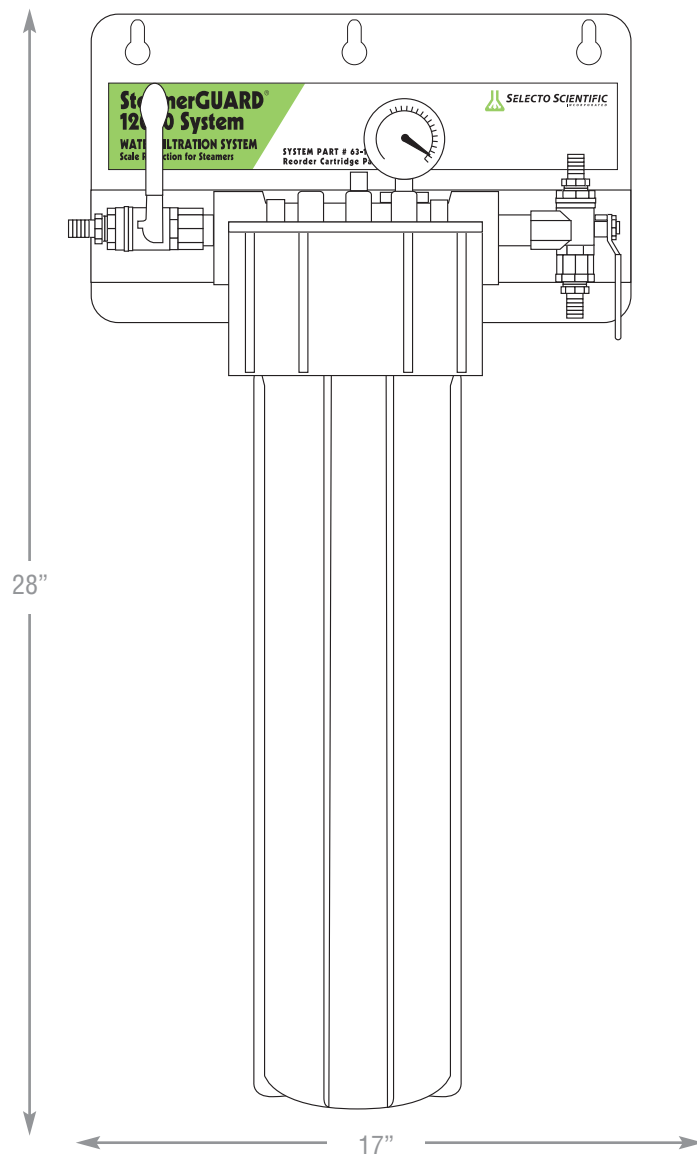

Rated capacity is based on extensive field testing in very challenging water conditions. This testing is performed by Selecto Scientific and its assignees.

## SPECIFIED TO:

- Reduce maintenance on steam generators
- Minimize under cooked food caused by lack of steam volume
- Reduce scale build up on heating elements, steam distribution and circulation fans and bearings
- Stop pitting and corrosion of equipment

## SPECIFIED FOR:

- Steam generators and steam boilers with flush/blow down system

## TECHNOLOGY:

- CeramicMATRIX
- NanoCRYSTAL
- Molded CarbonBLOCK

## INGREDIENT WATER

### CONTAMINANT REDUCTION OF:

- Lime Scale
- Calcium
- Turbidity
- Alkalinity
- Chlorine

## APPLICATIONS:

All Steamers and Combi-Ovens, not Flash Units



• ANSI/NSF Component System tested and certified by NSF International. Please contact [www.NSF.org](http://www.NSF.org) for specifications.



**SELECTO SCIENTIFIC**  
INCORPORATED

3980 Lakefield Court, Suwanee, GA 30024 USA • 800-635-4017 • 678-475-0799  
[www.selectoinc.com](http://www.selectoinc.com) • ©2004 Selecto Scientific, Inc. All Rights Reserved.