

MF5/600

System Part: Replacement Cartridge: Kit #109-0010
#60-5600 Pre Filter 1: #101-230 CB Filter 2: #101-290

- SPECIFICATIONS:**
- Rated Capacity: (Chlorine) 20,000 gallons
 - Flow Rate: 5 gpm
 - Min/Max Pressure: 40–125 psi.
 - Min/Max Temperature: 40°–100° F
 - Inlet/Outlet Size: 1/2 Inch Barbed Fitting
 - Shipping Weight: 25 lbs.
 - Dimensions (W/D/H): 23/9/19”

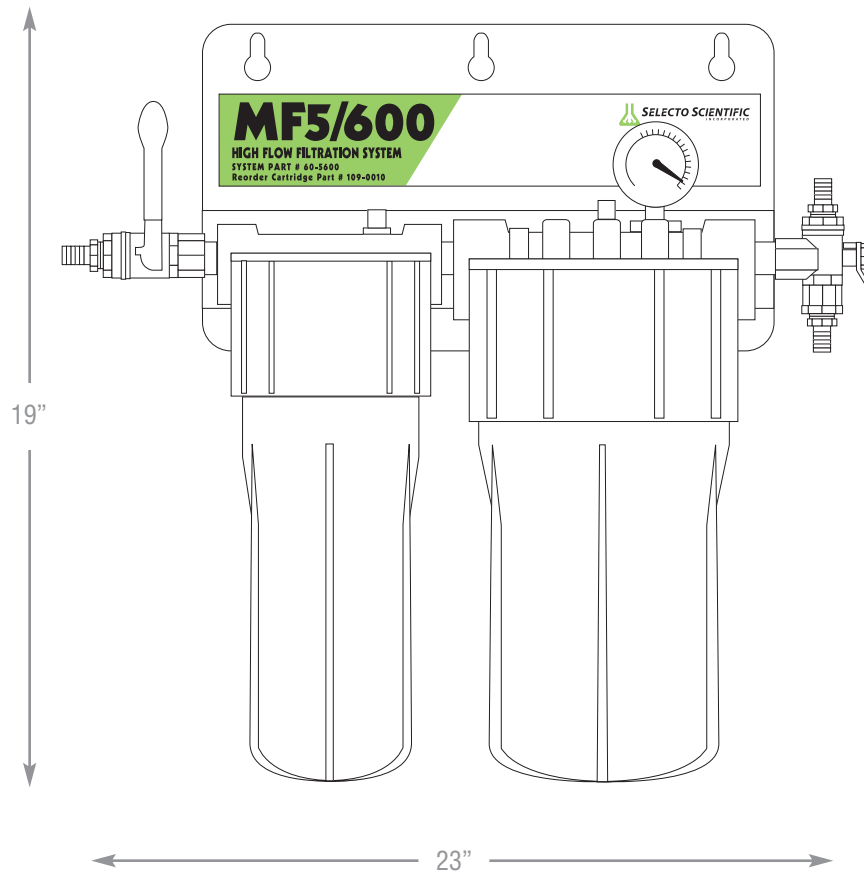

FOUNTAIN APPLICATION

FOR: Chlorine, Sediment, Cysts, THMs, VOCs, Organics, Tannins, Turbidity Reduction

VOLUME:
Medium

SPECIFIED TO:

- Improve the taste of fountain beverages
- Provide, safe, clean, clear cyst free ingredient water
- Reduce equipment maintenance
- Increase fountain sales

SPECIFIED FOR:

- Fountain and multi-use application such as ice, coffee and tea
- Increase carbonation

TECHNOLOGY:

- CeramicMATRIX
- NanoTITANIUM
- Molded CarbonBLOCK
- TurboFLOW Dynamics

INGREDIENT WATER

CONTAMINANT REDUCTION OF:

Chlorine, Bad Tastes and Odors, Total Organic Carbon, Volatile Organic Compounds, Tannins, Turbidity, Giardia Cyst, Cryptosporidium Cysts and Trihalomethanes

APPLICATIONS:

1 to 3 carbonators, multi-use

Rated capacity is based on extensive field testing in very challenging water conditions. This testing is performed by Selecto Scientific and its assignees.



• ANSI/NSF For MF600
System tested and certified by NSF International. Please contact www.NSFF.org for specifications.



SELECTO SCIENTIFIC
INCORPORATED

3980 Lakefield Court, Suwanee, GA 30024 USA • 800-635-4017 • 678-475-0799
www.selectoinc.com • ©2004 Selecto Scientific, Inc. All Rights Reserved.