

LR-BB50 HEAVY DUTY LEAD FILTRATION SYSTEM



APPLICATIONS

- ◆ Whole House

FEATURES • BENEFITS

- ◆ Professional grade lead reduction system for the home
- ◆ NSF/ANSI Standard 53 certified to reduce cysts such as *Cryptosporidium* and *Giardia* by mechanical means
- ◆ Maximum filtration with minimal pressure drop
- ◆ Integrated bypass valve for easier cartridge change-outs
- ◆ Complete system with cartridge, wrench, mounting bracket kit and manual

EPA Est. No. 090375-MEX-001

INSTALLATION TIPS

- ◆ Choose a mounting location suitable to support the full weight of the system when operating.
- ◆ Make sure to properly lubricate o-ring prior to use.
- ◆ Use 3/4" water line (optional reducer bushings included).
- ◆ Install vertically with bowl hanging down.
- ◆ Allow 2-1/2" (6.35 cm) clearance below the cartridge for easy cartridge replacement.

OPERATION TIPS

- ◆ Replace cartridge if flow rate decreases.
- ◆ Do not exceed service flow rate.
- ◆ Inspect o-ring during each cartridge change. Lubricate and/or replace if necessary.

SIZING

- ◆ Service Flow Rate: Maximum 10 gpm

INCLUDES

- ◆ 20" Filter housing with bypass cap
- ◆ 20" Filter cartridge
- ◆ Wrench
- ◆ Mounting bracket with screws
- ◆ Installation and operation manual

LR-BB50 HEAVY DUTY LEAD FILTRATION SYSTEM

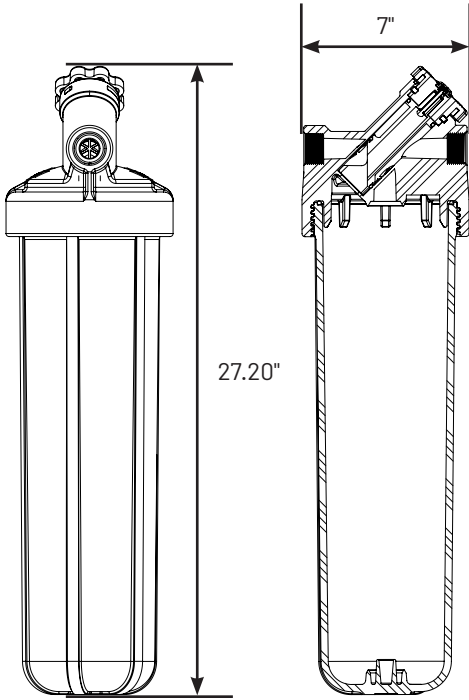

SPECIFICATIONS

- ◆ **System (Model/Part No.)**
LR-BB50/160410
- ◆ **Housing Size**
20" Heavy duty
- ◆ **Inlet Size**
1" FPT
- ◆ **Housing Material**
Polypropylene
- ◆ **System Dimensions**
27.20" H x 7" W
(691 mm x 178 mm)
- ◆ **Cartridge Type**
FibreDyne[®] Carbon Block
- ◆ **Contaminant Reduction**
Lead, Cyst: NSF/ANSI Standard 53 certified to reduce cysts such as *Cryptosporidium* and *Giardia* by mechanical means.
- ◆ **Micron Rating**
0.5
- ◆ **Filter Life***
4 - 5 months
- ◆ **Capacity**
40,000 gallons (151416.47 Liters)
- ◆ **Flow Rate**
10 gpm (37.85 Lpm)
- ◆ **Certification**
NSF/ANSI Std. 53
CSA Standard B483.1
- ◆ **Feed Pressure Range**
30 - 90 psi (2.06 - 6.20 bar)
- ◆ **Temperature Range**
40° - 100°F (4.4 - 37.8°C)
- ◆ **Replacement Cartridge**
(Model/Part No.)
LR-FB20BB / 655210-43 (6/Case)

* Filter life dependent on gallon usage and overall incoming water quality.

EPA Est. No. 090375-MEX-001



System Tested and Certified by NSF International against CSA B483.1 and NSF/ANSI Standard 53 for the reduction of Lead and Cyst.



13845 Bishops Dr. | Suite 200 | Brookfield, WI 53005 | United States
P: 262.238.4400 | Customer Service: 800.279.9404 | tech-support@pentair.com | pentair.com

§For a detailed list of where Pentair trademarks are registered, please visit www.pentair.com/registrations. Pentair trademarks and logos are owned by Pentair plc or its affiliates. Third party registered and unregistered trademarks and logos are the property of their respective owners.

© 2020 Pentair Residential Filtration, LLC. All rights reserved.

4005495 Rev B FE20