

REVISIONS						
SHEET	ZONE	REV.	ECO	DESCRIPTION	DATE	APPROVED
1	ALL	A	50253	2017 FORMAT UPDATE	10/18/2018	HRC

**PLUG,  
(BRASS, NICKEL  
AND CHROME PLATED)**

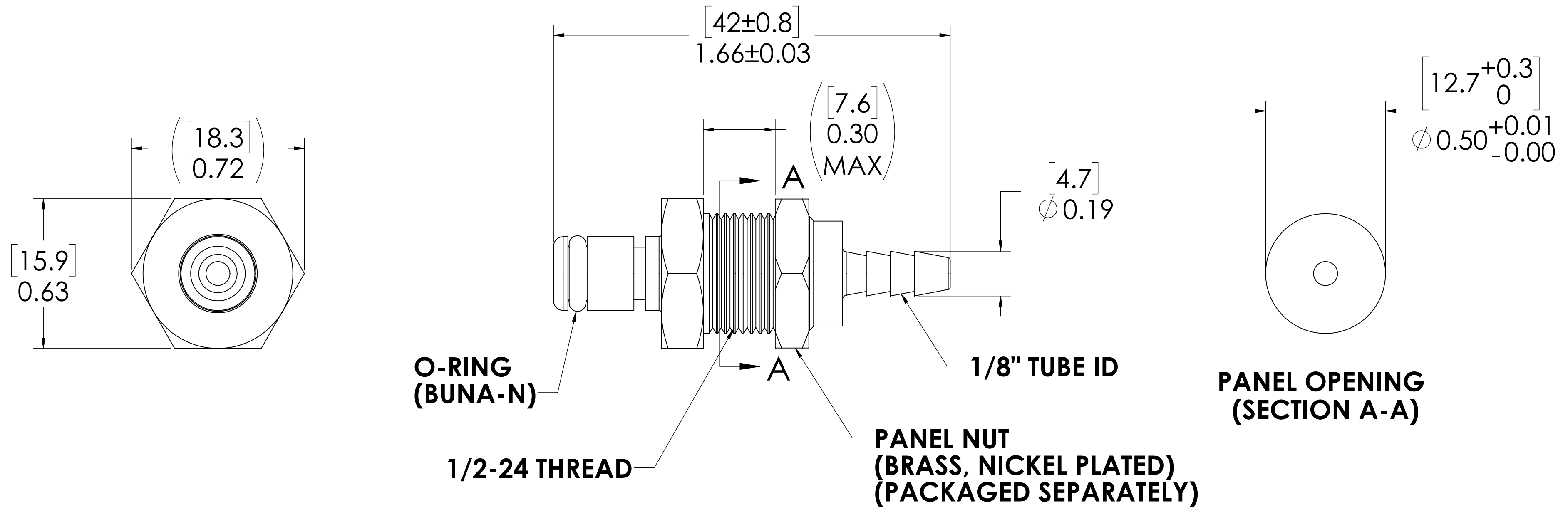
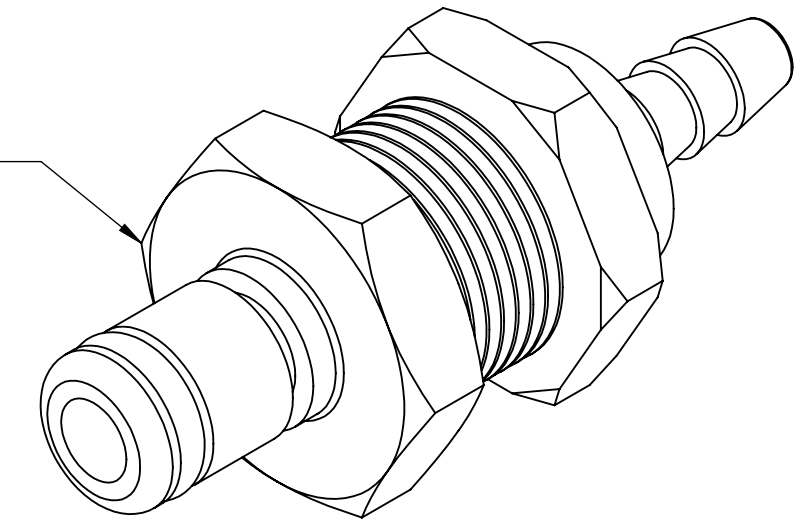

**NOTES:**

1. MATERIAL: BRASS
2. COLOR: CHROME
3. O-RING MATERIAL: BUNA-N
4. O-RINGS LUBRICATED WITH FOOD GRADE SILICONE OIL, 350 CST.

**FOR REFERENCE ONLY**

UNLESS OTHERWISE SPECIFIED: DIMENSIONS ARE IN INCHES TOLERANCES: FRACTIONAL ± 1/32 ANGULAR: MACH ± 0.5 BEND ± 2 ONE PLACE DECIMAL ± 0.1 TWO PLACE DECIMAL ± 0.01 THREE PLACE DECIMAL ± 0.005 TWO PLACE DUAL (mm) [±0.12]	DRAWN	RDA	1/17/2018	
	CHECKED	HRC	1/17/2018	
	ENG APPR.	HRC	10/18/18	
	MFG APPR.	BDB	10/18/18	
PRODUCTION	LS	10/18/18		<b>PART NO:</b> 20CB-PB3-02 <b>DESCRIPTION:</b> LinkTech 20CB Series Panel Mt. Male, Non-valved, 125 HB, Chrome Brass
<small>THE INFORMATION CONTAINED IN THIS DRAWING IS THE SOLE PROPERTY OF LINKTECH LLC. ANY REPRODUCTION OR DISCLOSURE IN PART OR AS A WHOLE WITHOUT THE WRITTEN PERMISSION OF LINKTECH LLC IS STRICTLY PROHIBITED.</small>	COMMENTS:			<b>SIZE</b> DWG. NO. REV <b>C</b> 20CB200169 <b>A</b>
SCALE: NTS		WEIGHT:	SHEET 1 OF 1	