

REVISIONS						
SHEET	ZONE	REV.	ECO	DESCRIPTION	DATE	APPROVED
1	ALL	A	50011	INITIAL RELEASE	8-23-12	DHJ
1	ALL	B	50242	PIN, PIN SPRING & 2017 FORMAT UPDATE	10/18/2018	HRC

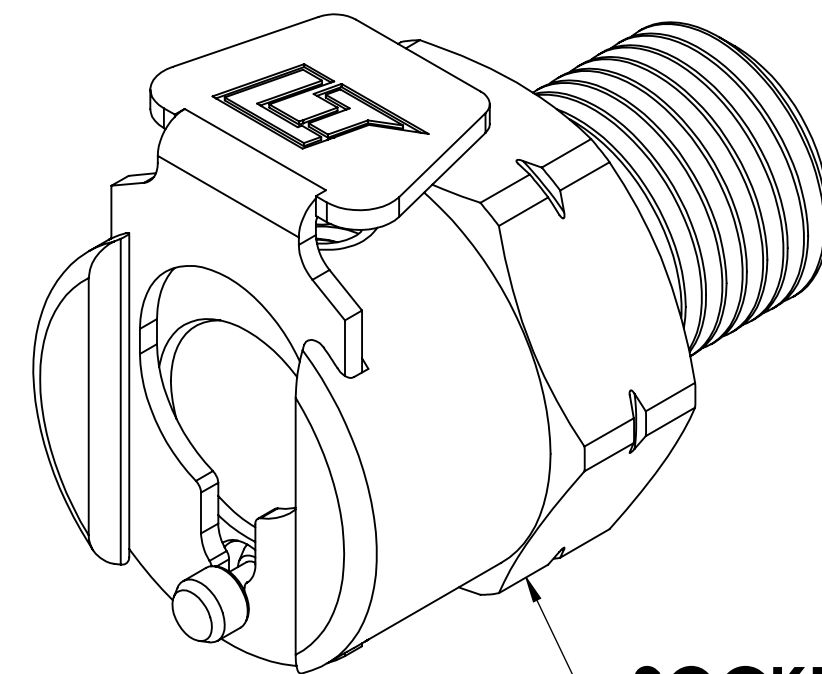

**SOCKET,
(BRASS, NICKEL AND
CHROME PLATED)**

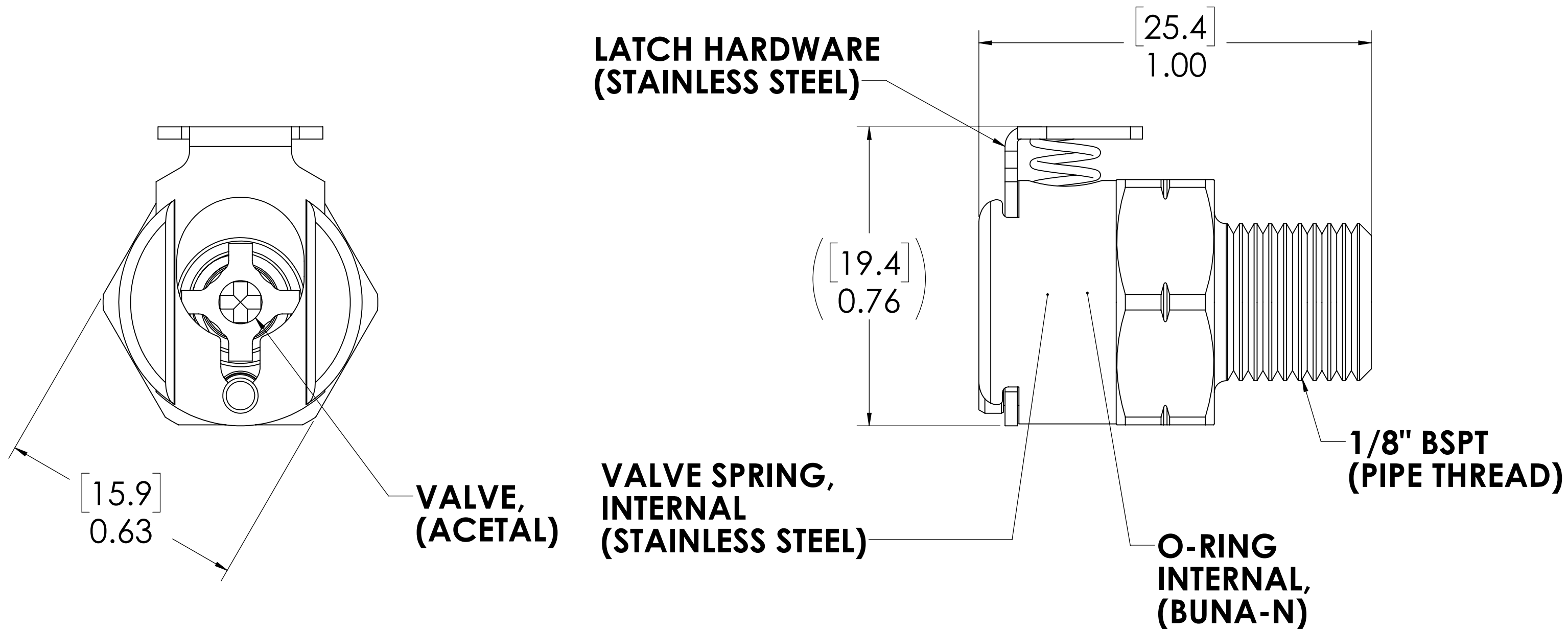

NOTES:

1. MATERIAL: BRASS
2. FINISH: CHROME
3. O-RING MATERIAL: BUNA-N
4. O-RINGS LUBRICATED WITH FOOD GRADE SILICONE OIL, 350 CST.

FOR REFERENCE ONLY

<small>UNLESS OTHERWISE SPECIFIED: DIMENSIONS ARE IN INCHES TOLERANCES: FRACTIONAL ± 1/32 ANGULAR, MACH ± 0.5 BEND ± 2 ONE PLACE DECIMAL ± 0.1 TWO PLACE DECIMAL ± 0.01 THREE PLACE DECIMAL ± 0.005 TWO PLACE DUAL (mm) [±0.12]</small>	DRAWN	HRC	8/18/12	
	CHECKED	HRC	8/18/12	
	ENG APPR.	HRC	10/18/18	
	MFG APPR.	BDB	10/18/18	
PRODUCTION	LS	10/18/18		PART NO: 20CBV-SB1-02BSPT DESCRIPTION: LinkTech 20CB Series Male Thread Female, Valved, 1/8" BSPT, Chrome Brass
<small>PROPRIETARY AND CONFIDENTIAL THE INFORMATION CONTAINED IN THIS DRAWING IS THE SOLE PROPERTY OF LINKTECH LLC. ANY REPRODUCTION OR DISCLOSURE IN PART OR AS A WHOLE WITHOUT THE WRITTEN PERMISSION OF LINKTECH LLC IS STRICTLY PROHIBITED.</small>	COMMENTS:			SIZE DWG. NO. REV C 20CB200100 B
SCALE: NTS		WEIGHT:	SHEET 1 OF 1	