

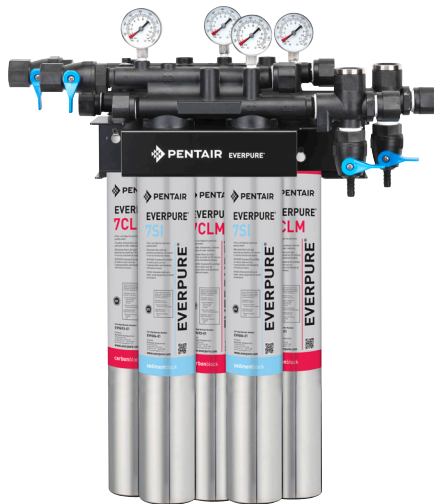

# EVERPURE® QC7I DIO PLATFORM WITH 7CLM/7SI

INTEGRATES FOUNTAIN AND ICE TREATMENT APPLICATIONS INTO A TWO-SYSTEM, SINGLE MANIFOLD CONFIGURATION

QC7I DIO Platform with 7CLM/7SI: EV9278-40  
7CLM Replacement Cartridge 1 PK: EV9693-01  
7SI Replacement Cartridge 1 PK: EV9606-01



## APPLICATIONS

Fountain  
Ice

## FEATURES • BENEFITS

Integrated header design incorporates two (2) independent systems into a single configuration providing two (2) distinct water qualities for multiple applications: primary filtration for fountain and secondary filtration with scale inhibitor for ice

Small system footprint is easy to install and service with built-in water shut-off and flushing valves on both water outlets

NSF/ANSI Standard 53 certified to reduce cysts such as *Cryptosporidium* and *Giardia* by mechanical means

### 7CLM System

Reduces chloramines, chlorine taste & odor and other offensive contaminants that can adversely affect the taste of beverages

Improves the taste of fountain beverages and helps retain carbonation

Exclusive filtration technology provides superior chlorine taste & odor reduction and micro-filters dirt and particles as small as 0.5 micron in size by mechanical means

Helps protect drink system seals, gaskets, pumps and tubes from chloramines damage

### 7SI System

Utilizes depth filtration and Fibredyne™ media for superior dirt-holding capacity

Reduces water-related ice machine problems caused by scale buildup from dirt and dissolved minerals\*

Self-contained scale inhibitor feed keeps ice machines functioning at full capacity\*

Reduces maintenance and service costs by reducing scale which can result in clogging of distribution lines, malfunction of probes, floats, pumps, solenoids and valves, and higher energy consumption.

\*as tested by Pentair Everpure

## INSTALLATION TIPS

Connect minimum 1/2" (1.3 cm) water line.

Install vertically with cartridge hanging down.

Allow 2-1/2" (6.35 cm) clearance below the cartridge for easy cartridge replacement.

Flush 7CLM and 7SI Cartridges by running water through filter for five (5) minutes at full flow.

This system must be installed and maintained according to the manufacturer's instructions, including installation and replacement of filter cartridges.

## OPERATION TIPS

Change cartridges on a regular six (6) month preventative maintenance program.

Change cartridges when capacity is reached or when pressure falls below 10 psi (0.7 bar).

Service flow rate must not exceed cartridge rating.

Always flush the filter cartridge at time of installation and cartridge change.

# EVERPURE® QC7I DIO PLATFORM WITH 7CLM/7SI

## EV9278-40/EV9693-01/EV9606-01

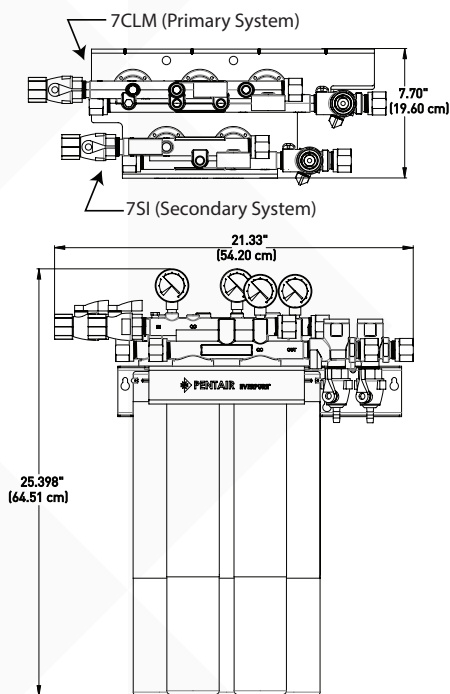

### SPECIFICATIONS

#### QC7I Triple-7CLM System Service Flow Rates and Capacities

@ 3 gpm (11.4 Lpm):  
24,000 gallons/90,850 L

@ 4 gpm (15.1 Lpm):  
16,500 gallons/62,459 L

@ 5.1 gpm (11.4 Lpm):  
10,800 gallons/40,882

#### QC7I Twin 7SI Twin System Service Flow Rate and Capacity

@ 7.0 gpm (26.5 Lpm):  
50,000 gallons/189,271 L

**Pressure Requirements**  
10 - 125 psi (0.7 - 8.6 bar)

**Operating Temperature**  
35 - 100°F (2 - 38°C)

**Overall Dimensions**  
25.398" L x 21.33" W x 7.70" D  
(64.51 cm x 54.2 cm x 19.6 cm)

**Inlet Connections**  
2 @ 3/4" NPT

**Outlet Connections**  
2 @ 1/2" barb

**Electrical Connection**  
None



QC7I Twin-7SI System Tested and Certified by NSF International against NSF/ANSI Standard 42 and 53 for the reduction of:

**Standard No. 42 — Aesthetic Effects**  
Mechanical Filtration  
Nominal Particulate Class I  
**Standard No. 53 - Health Effects**  
Mechanical Filtration  
Cyst



QC7I Triple-7CLM System Tested and Certified by NSF International against NSF/ANSI Standard 42 and 53 for the reduction of:

**Standard No. 42 — Aesthetic Effects**  
Chemical Reduction  
Taste and Odor  
Chloramines  
Chlorine  
Mechanical Filtration  
Nominal Particulate Class I  
**Standard No. 53 - Health Effects**  
Mechanical Filtration  
Turbidity  
Cyst

The contaminants or other substances removed or reduced by this drinking water system are not necessarily in your water. Do not use with water that is microbiologically unsafe or of unknown quality without adequate disinfection before or after the system. Systems certified for cyst reduction may be used with disinfected water that may contain filterable cysts.

### WARRANTY

Everpure water treatment systems by Pentair® (excluding replaceable elements) are covered by a limited warranty against defects in material and workmanship for a period of five years after date of purchase. Everpure replaceable elements (filter cartridges and water treatment cartridges) are covered by a limited warranty against defects in material and workmanship for a period of one year after date of purchase. See printed warranty for details. Pentair will provide a copy of the warranty upon request.

EPA No. 002623-IL-002



### FILTRATION & PROCESSING SOLUTIONS

EVERPURE-SHURFLO WORLD HEADQUARTERS, 1040 MUIRFIELD DRIVE, HANOVER PARK, IL 60133 USA • WWW.EVERPURE.COM  
800.942.1153 (US ONLY) • 630.307.3000 MAIN • 630.307.3030 FAX • CSEVERPURE@PENTAIR.COM EMAIL

EVERPURE-SHURFLO AUSTRALIA, 1-21 MONASH DRIVE, DANDENONG SOUTH, VIC 3175, AUSTRALIA  
011.1300 576 190 TEL • 011.61.39.562.7237 FAX • AU.EVERPURE@PENTAIR.COM EMAIL

EVERPURE-SHURFLO CHINA, 21F CLOUD 9 PLAZA, NO 1118, SHANGHAI, 200052, CHINA  
86.21.3211.4588 TEL • 86.21.3211.4580 FAX • CHINA.WATER@PENTAIR.COM EMAIL

EVERPURE-SHURFLO INDIA, GREEN BOULEVARD, B-9/A, 7TH FLOOR - TOWER B SECTOR 62, NOIDA - 201301  
91.120.419.9444 TEL • 91.120.419.9400 FAX • INDIACUSTOMER@PENTAIR.COM EMAIL

EVERPURE-SHURFLO EUROPE, PENTAIR WATER BELGIUM BVBA, INDUSTRIEPARK WOLFSTEE, TOEKOMSTLAAN, 30 B-2200 HERENTALS, BELGIUM  
+32.(0).14.283.500 TEL • +32.(0).14.283.505 FAX • SALES@EVERPURE-EUROPE.COM EMAIL

EVERPURE-SHURFLO JAPAN INC., HASHIMOTO MN BLDG. 7F, 3-25-1 HASHIMOTO, MIDORI-KU, SAGAMIHARA-SHI KANAGAWA 252-0143, JAPAN  
81.(0)42.775.3011 TEL • 81.(0)42.775.3015 FAX • INFO@EVERPURE.CO.JP EMAIL

EVERPURE-SHURFLO SOUTHEAST ASIA, SOUTHEAST ASIA, 390 HAVELOCK ROAD, #04-01 KING'S CENTRE, SINGAPORE 169662  
65.6768.5800 TEL • 65.6737.5149 FAX • CSEVERPURE@PENTAIR.COM EMAIL

All Pentair trademarks and logos are owned by Pentair, Inc. or its affiliates. All other registered and unregistered trademarks and logos are the property of their respective owners. Because we are continuously improving our products and services, Pentair reserves the right to change specifications without prior notice. Pentair is an equal opportunity employer.