

REVISIONS						
SHEET	ZONE	REV.	ECO	DESCRIPTION	DATE	APPROVED
1	ALL	A	50253	UPDATE DWG TO 2017 FORMAT	2/6/2018	HRC

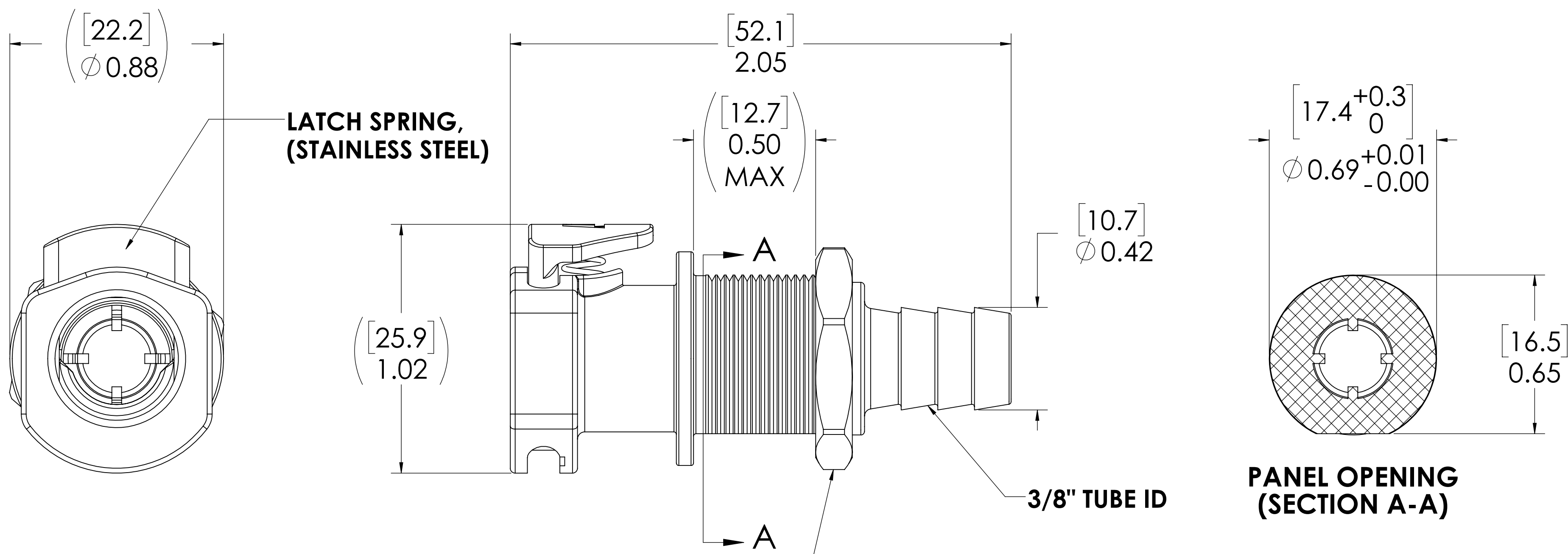
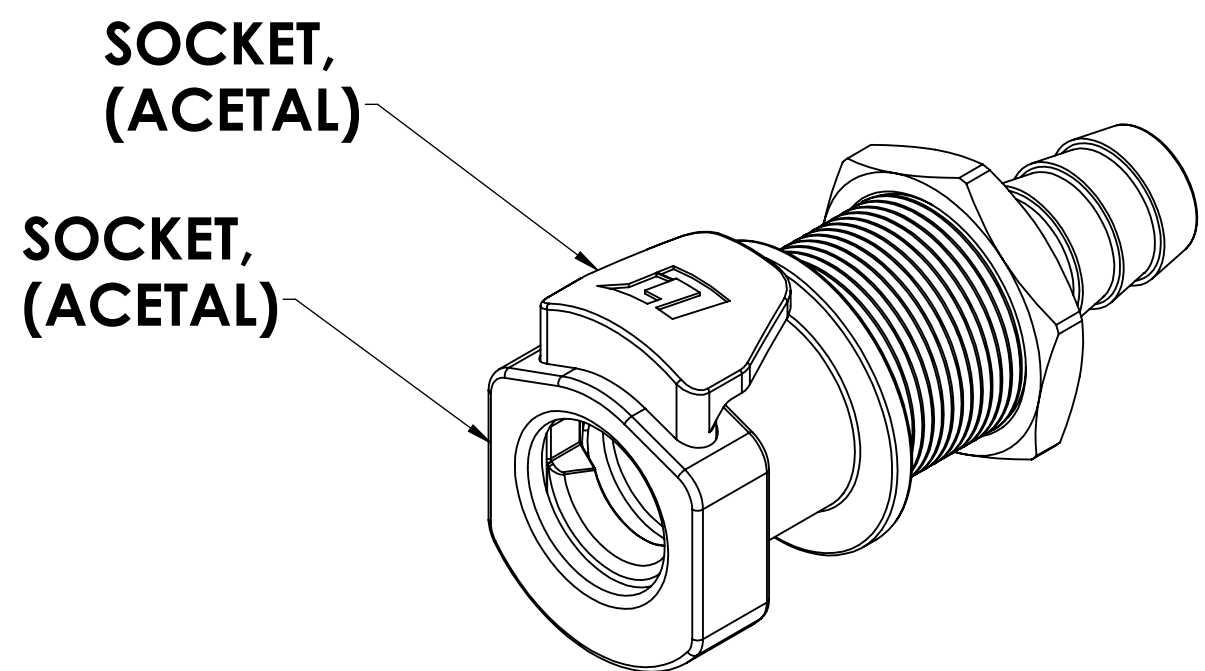

**PANEL NUT (NICKEL PLATED BRASS, 11/16" HEX) PACKAGED SEPARATELY**

**FOR REFERENCE ONLY**

- NOTES:**
- MATERIAL: ACETAL
  - COLOR: NATURAL WHITE

<small>UNLESS OTHERWISE SPECIFIED:          DIMENSIONS ARE IN INCHES          TOLERANCES:          FRACTIONAL ± 1/32          ANGULAR: MACH ± 0.5 BEND ± 2          ONE PLACE DECIMAL ± 0.1          TWO PLACE DECIMAL ± 0.01          THREE PLACE DECIMAL ± 0.005          TWO PLACE DUAL (mm) [± 0.12]</small>	DRAWN	RDA	7/12/2017	 <b>PART NO: 50AC-S3-06</b> <b>DESCRIPTION: LinkTech 50AC Series Panel Mt. Female, Non-valved, 375 HB, Natural Acetal</b>
	CHECKED	HRC	8/4/2017	
	ENG APPR.	HRC	02-06-18	
	MFG APPR.	BDB	02-06-18	
PRODUCTION	RK	02-06-18		<small>PROPRIETARY AND CONFIDENTIAL</small> <small>THE INFORMATION CONTAINED IN THIS DRAWING IS THE SOLE PROPERTY OF LINKTECH LLC. ANY REPRODUCTION OR DISCLOSURE IN PART OR AS A WHOLE WITHOUT THE WRITTEN PERMISSION OF LINKTECH LLC IS STRICTLY PROHIBITED.</small>
COMMENTS:				<small>SIZE DWG. NO. REV</small> <b>C 50AC500046 A</b>
SCALE: NTS		WEIGHT:		SHEET 1 OF 1