

REVISIONS						
SHEET	ZONE	REV.	ECO	DESCRIPTION	DATE	APPROVED
1	ALL	A	50242	INITIAL RELEASE	8/18/2017	HRC

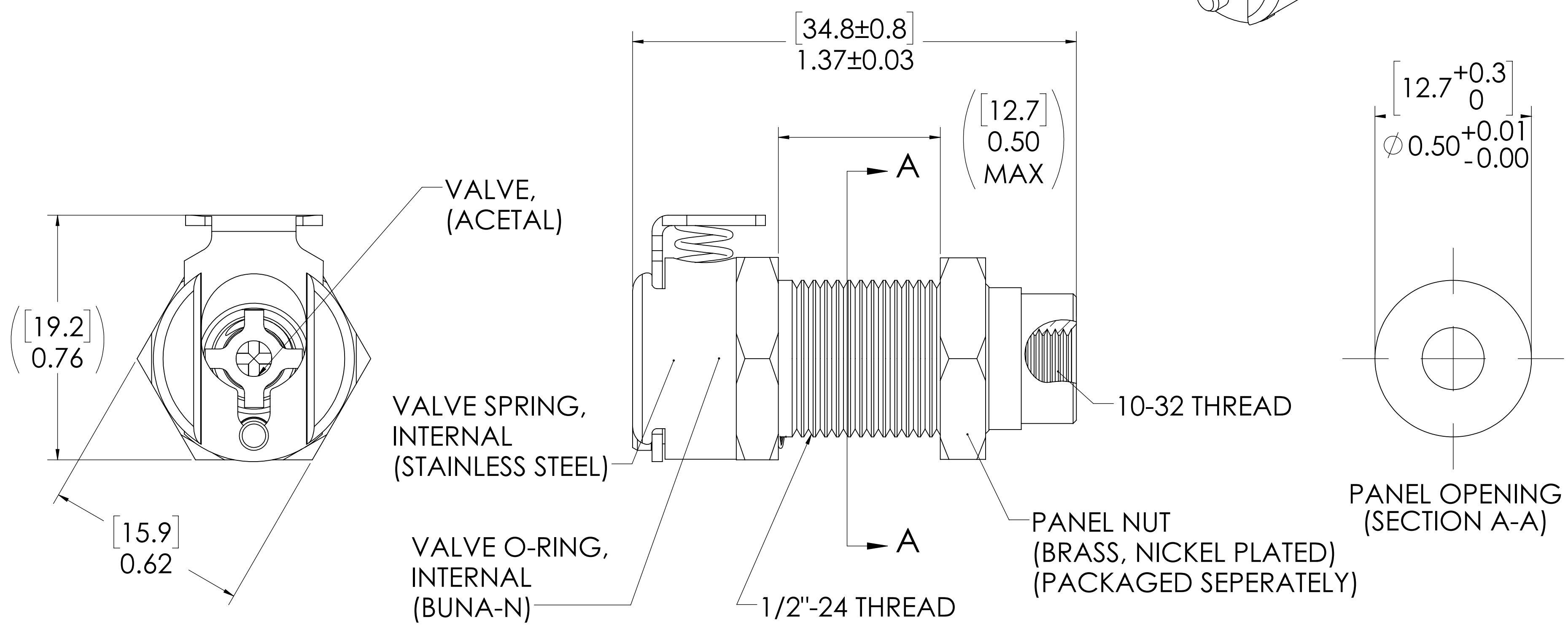
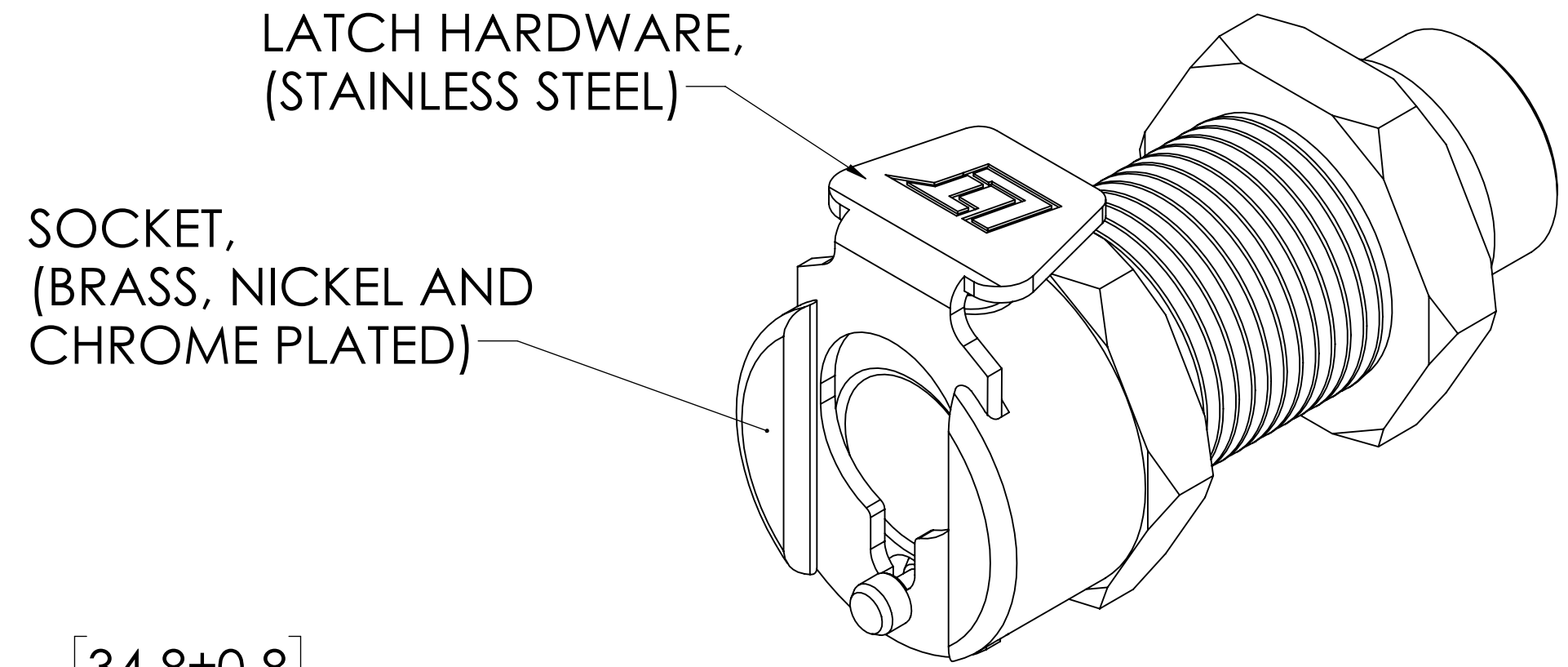

- NOTES:**
- MATERIAL: BRASS
 - FINISH: CHROME
 - O-RING MATERIAL: BUNA-N
 - O-RINGS LUBRICATED WITH FOOD GRADE SILICONE OIL, 350 CST.

FOR REFERENCE ONLY

<small>UNLESS OTHERWISE SPECIFIED: DIMENSIONS ARE IN INCHES TOLERANCES: FRACTIONAL ±1/32 ANGULAR: MACH ±0.5 BEND ±2 ONE PLACE DECIMAL ±0.1 TWO PLACE DECIMAL ±0.01 THREE PLACE DECIMAL ±0.005 TWO PLACE DUAL (mm) [±0.12]</small>	DRAWN	DHJ	9-16-09	
	CHECKED	HRC	3/12/12	
	ENG APPR.	HRC	08-18-17	
	MFG APPR.	BDB	08-18-17	
<small>PROPRIETARY AND CONFIDENTIAL</small>	Q.A.	JJB	08-18-17	PART NO: 20CBV-SB19-1032 DESCRIPTION: LinkTech 20CB Series Panel Mt. Female, Female Thread, Valved, 10/32, Chrome Brass
<small>THE INFORMATION CONTAINED IN THIS DRAWING IS THE SOLE PROPERTY OF LINKTECH LLC. ANY REPRODUCTION OR DISCLOSURE IN PART OR AS A WHOLE WITHOUT THE WRITTEN PERMISSION OF LINKTECH LLC IS STRICTLY PROHIBITED.</small>	COMMENTS:			SIZE DWG. NO. REV C 20CB200049 A
	SCALE: NTS	WEIGHT:		SHEET 1 OF 1