



READ THESE IMPORTANT POINTS BEFORE INSTALLING THIS KLEENSTEAM® SYSTEM:

1. Always use a minimum 3/8" O.D. copper tubing from the outlet of the KleenSteam unit to your steamer.
2. Use the water from the KleenSteam unit only on steamer feed and make-up water.
DO NOT USE TO TREAT CONDENSATE COOLING WATER.
3. For many years, Everpure has worked closely with all major foodservice equipment manufacturers to assure the highest possible degree of compatibility and optimal performance of the KleenSteam System with their steamers.

To help ensure satisfactory operation, we recommend that you obtain and read the equipment manufacturer's operating and maintenance instructions for your specific steamer model. Follow the manufacturer's instructions and procedures for installation, maintenance and cleaning. Or consult with the manufacturer's representative or technical service personnel for guidance regarding any differences between their directions and those included with the KleenSteam System. Failure to do so may affect equipment performance and/or warranty coverage.

INSTALLATION INSTRUCTIONS

Do not make any disconnections until you have inspected the contents of the KleenSteam unit carton. You should have:

- KleenSteam plate-mounted system consisting of:
 - Quick-change filter head with 7CB5 Filter Cartridge (BB System) or 4CB5 Filter Cartridge (CT System)
 - AR-X Housing
 - ScaleStick SS-10
 - Dip Tube for ScaleKleen delimer
- (2) ScaleKleen 2.2 lb. packets (BB System)
- (2) ScaleKleen 7 oz packets (CT System)

If you do not have these components, do not attempt to install this system!

Contact your local Everpure Master Distributor for assistance.

1. Shut off power to the steamer.
2. Shut off the inlet water to the steamer at the supply valve.
3. Attach the plate-mounted KleenSteam system to a suitable structure in an accessible location. Mounting holes are provided on the mounting plate. **THE KLEENSTEAM BB WEIGHS 25 POUNDS IN SERVICE. THE KLEENSTEAM CT WEIGHS 15 POUNDS IN SERVICE.**
4. Attach the inlet of the KleenSteam unit to a COLD water supply line only. Hot water will damage the KleenSteam unit and will void the warranty. Use a minimum of 3/8" tubing.
5. Attach only copper or stainless steel tubing from the outlet of the KleenSteam system to the inlet feed/makeup water connection on your steamer. Keep the tubing run to the steamer under 20 feet. **DO NOT CONNECT TO CONDENSATE COOLING LINE.**
6. Install 7CB5 or 4CB5 Filter Cartridge into the quick-change filter head as instructed on the cartridge label.
7. Unscrew the clear bowl and insert the SS-10 ScaleStick into the center port of the AR-X head. The friction fit between the cartridge and port should allow the cartridge to be suspended while placing the clear bowl over the cartridge and threading it into place on the head. *NOTE: The cartridge must be replaced when the level of the white material drops below 1/4" in depth. Take care not to block the KleenSteam unit from view when installing.*
8. With the supply water to the KleenSteam unit off, rotate the inlet valve handle to the open position.
9. Attach tubing to the outlet of the flushing valve and open the valve.

10. Turn on the inlet supply water and flush the 7CB5 or 4CB5 cartridge to drain (or bucket) at full force for several minutes. This will flush incidental carbon fines and any trapped air.

11. After flushing, close the flushing valve handle until the water stops.

12. Depress red pressure relief button on the AR-X head until water flows out and around the red button.

13. Inspect KleenSteam unit for leaks, and correct as required.

14. Turn on power to steamer.

DELIMING INSTRUCTIONS

In addition to reducing harmful chlorine and controlling limescale build-up, the KleenSteam system may be used to conveniently introduce deliming material into the steamer without disturbing existing piping.

Use only Everpure ScaleKleen deliming material. ScaleKleen is a highly effective, safe and environmentally friendly de-scaling product. Its routine maintenance usage removes built-up scale in steam equipment easily and quickly. This enhances steamer performance, reduces operating costs and helps prevent costly repairs and unexpected downtime. Other deliming products may contain harsh acids that can damage the housing materials or clog orifices. Generally, use one 2.2 lb (1 kg) package to delime most countertop units and two 2.2 lb packages to delime most boiler-based units.

1. Turn off the power switch on the steamer.
2. Blow down steamer. Blow down is done automatically on some steamers when power is turned off. Manually blow down the steamer if it is not automatic.
3. Turn off inlet water to Kleensteam system.
4. Depress the red relief button located on top of the AR-X head to relieve system pressure.
5. Unscrew the clear bowl and remove the cartridge. Dispose of the exhausted cartridge in normal trash and empty bowl of any remaining water.
6. Remove the dip tube from it's holding clip, located on the backplate. Insert the tube. O-ring first, into the center port of the AR-X head until the dip tube bottoms out.
7. Open one kilogram (2.2 lb) package of ScaleKleen™ and empty it into the clear bowl. Wipe off any excess ScaleKleen™ material which may be on the bowl threads or O-ring.

8. Thread the bowl back into the head – hand tight only!
NOTE: The dip tube may become packed with ScaleKleen™. This is normal and will not affect the deliming procedure.
9. Turn on the inlet water to the KleenSteam unit by rotating the inlet valve handle.
10. Turn on the power to the steamer. *NOTE: This action will quickly introduce the ScaleKleen™ material directly into the boiler chamber. If you are delimiting a countertop steamer, proceed to step 11.* If you are delimiting a boiler-base unit, monitor ScaleKleen™ level in bowl. When it drops to 1", quickly turn off inlet water at valve handle. Now relieve pressure and unscrew bowl from head. Add another kilogram of ScaleKleen™ to the bowl and reintroduce the material into the boiler. Repeat this procedure until two (2) 2.2 lb packages of ScaleKleen™ have been introduced into the boiler chamber.
11. With ScaleKleen™ material introduced into the boiler chamber and the inlet water turned on, make sure the boiler sump is flooded. Allow the steamer (countertop or boiler-based) to come up to operating temperature and pressure, and hold for one hour.
12. Thirty minutes into the delimiting procedure, turn on steam to cooking chamber(s) for one minute. This will delime the distribution lines, small orifices, and steam solenoid valves.
13. After one hour of delimiting the steamer at operating temperature and pressure, turn the steamer power switch to the off position.
14. Manually blow down the steamer if it is not done automatically when the power is turned off.
NOTE: Check the pH of the blow down water. If the pH is acidic (below 7.0), then the boiler has been completely descaled. If the pH is alkaline (above 7.0), then there is still scale remaining in the boiler. Repeat steps 7 through 14 until the pH from the boiler blow down water is below 7.0.
15. Fill the boiler with fresh, clean water and repeat blow down until the water in the boiler is equal to the raw (incoming) water pH. This will remove any unused ScaleKleen and undissolved loose scale remaining in the boiler.
NOTE: Depending on the steam generator fill probe configuration on your steamer, de-scaling compounds may leave residual foam bridging probe electrodes. This can cause a false water level indication leading to "dry firing" of the boiler that can burn out heating elements.
To help ensure against incorrect probe operation, follow all of the instructions provided for de-scaling. This includes adding an additional 1 to 1½ gallons of water to the de-scaling port(s) once automatic filling has stopped after the de-scaler drain cycle. This raises the water level above the fill probes, permitting them to be flushed clean and drained with the following drain cycle.
16. After the second blow down, turn the steamer power switch to the off position, and turn off the inlet water at the valve handle on the KleenSteam unit.
17. Relieve system pressure by depressing the red relief button on the head until all air is expelled and water begins to escape.
18. Unscrew the clear bowl and remove the dip tube from the head. **BE SURE TO REPLACE THE DIP TUBE IN IT'S HOLDER ON THE BACKPLATE!**
19. Install a new SS-10 cartridge into the head, and screw the bowl back into the head. Hand tighten only!
20. Turn on the inlet water. Relieve trapped air in the clear bowl by depressing the red relief button on the AR-X head until all air is expelled and water starts to escape.
21. Turn the steamer power switch to the on position. Steamer is now ready to be placed back into service.

REPLACEMENT PARTS

1. Contact your local Everpure dealer for filter cartridges or system replacement parts.

Description	Part Number
Dip tube assembly	EV3080-40
4CB5 filter cartridge (6-pack)	EV9617-16
7CB5 filter cartridge (6-pack)	EV9618-16
ScaleStick SS-10 (12-pack)	EV9799-02
ScaleKleen scale remover 2.2 lb. pkg. (4-pack)	EV9798-01
ScaleKleen remover 7 oz. pkg (24-pack)	EV9798-20

DIMENSIONS AND SPECIFICATIONS

	Model BB PN EV9797-00	Model CT EV9797
Width of Mounting Plate	19.75"	14"
System Depth (front to back)	8.0"	8.0"
Overall Length	31.0" (includes 2" for cartridge change)	18.25" (includes 2" for Cartridge change)
Inlet Connection	3/8" FPT	3/8" FPT
Outlet Connection	1/2" MPT	3/8" FPT
Minimum Water Pressure	20 psi	10 psi
Maximum Water Pressure	125 psi (non-shock)	125 psi (non-shock)
Maximum Water Temperature	80°F	80°F
Net Shipping Weight	23 lbs.	10 lbs.
Operating Weight	25 lbs.	15 lbs.

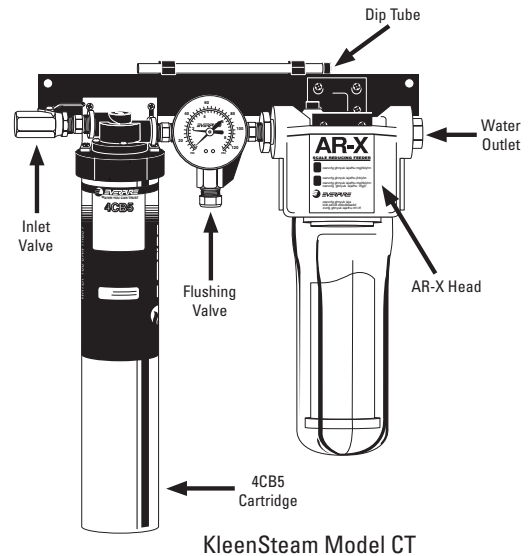
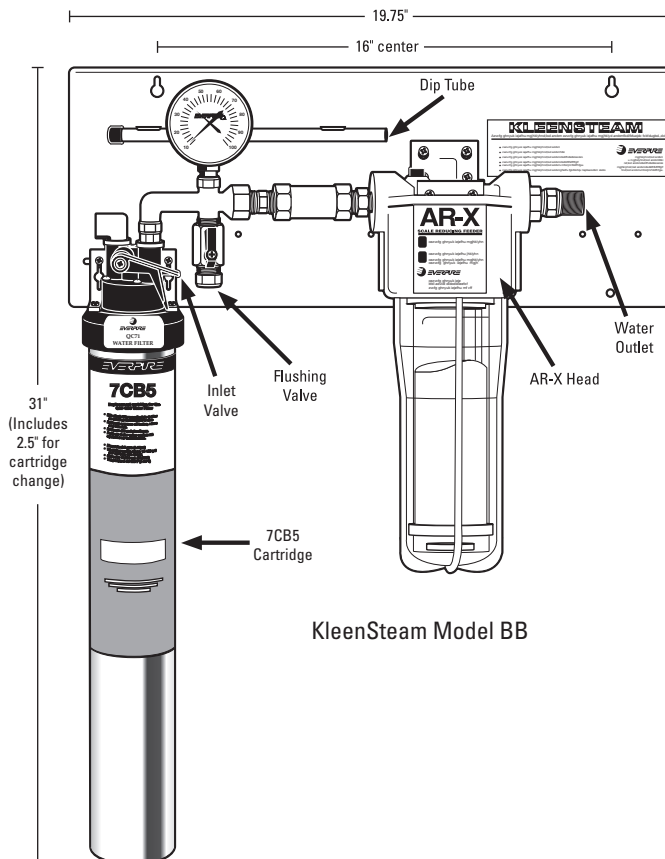

IMPORTANT NOTE:

Water from KleenSteam System should only be connected to the boiler feed, and not to the condenser connection of the steamer.

LIMITED WARRANTY

COMMERCIAL WATER TREATMENT EQUIPMENT

You have just purchased one of the finest water treatment units made. As an expression of our confidence in Everpure products, this product is warranted against defects in material and workmanship to the original end-user when installed in accordance with Everpure specifications. The warranty period commences from the date of purchase and is administered as follows:

For a period of ONE YEAR

Replaceable elements (i.e., filter & water treatment cartridges)*

For a period of FIVE YEARS

The entire system (excluding replaceable elements)

***This is for material & workmanship, not filter or water treatment cartridge life.**

The unit must be used in operating conditions that conform to Everpure's recommended design guidelines. This warranty will not apply if the unit has been modified, repaired or altered by someone not authorized by Everpure.

If a part described above is found defective within the specified period, you should notify Everpure technical service at the phone number listed below. Any part found defective within the terms of this warranty will be repaired or replaced (at Everpure's discretion) by your local dealer or Everpure technical service. You pay only freight from our factory and local dealer charges. Any repaired or replaced warranty item will be incorporated under the original warranty terms of the existing system.

We are not responsible for damage caused by accident, fire, flood, freezing, Act of God, misuse, misapplication, neglect, oxidizing agents (such as chlorine, ozone, chloramines and other related components), alteration, installation or operation contrary to our printed instructions, or by the use of accessories or components which do not meet Everpure's specifications. Refer to the specifications section in the Installation and Operating manual for approved application parameters.

Our product performance specifications are furnished with each water treatment unit. TO THE EXTENT PERMITTED BY LAW, EVERPURE DISCLAIMS ALL IMPLIED WARRANTIES, INCLUDING WITHOUT LIMITATION WARRANTIES OF MERCHANTABILITY AND FITNESS FOR PARTICULAR PURPOSE; TO THE EXTENT REQUIRED BY LAW, ANY SUCH IMPLIED WARRANTIES ARE LIMITED IN DURATION TO THE PERIOD SPECIFIED ABOVE FOR THE ENTIRE WATER TREATMENT UNIT. As a manufacturer, we do not know the characteristics of your water supply or the purpose for which you are purchasing this product. The quality of water supplies may vary seasonally or over a period of time, and your water usage rate may vary as well. Water characteristics can also differ considerably if this product is moved to a new location. For these reasons, we assume no liability for the determination of the proper equipment necessary to meet your requirements, and we do not authorize others to assume such obligations for us. Further, we assume no liability and extend no warranties, express or implied, for the use of this product with a non-potable water source or a water source which does not meet the conditions for use described in the owner's guide or performance data sheet for this product. OUR OBLIGATIONS UNDER THIS WARRANTY ARE LIMITED TO THE REPAIR OR REPLACEMENT (AT EVERPURE'S DISCRETION) OF THE FAILED PARTS OF THE WATER TREATMENT UNIT, AND WE ASSUME NO LIABILITY WHATSOEVER FOR DIRECT, INDIRECT, INCIDENTAL, CONSEQUENTIAL, SPECIAL, GENERAL OR OTHER DAMAGES.

Some states do not allow the exclusion of implied warranties or limitations on how long an implied warranty lasts, so the above limitation may not apply to you. Similarly, some states do not allow the exclusion of incidental or consequential damages, so the above limitation or exclusion may not apply to you. This warranty gives you specific legal rights, and you may also have other rights which vary from state to state. Consult your telephone directory for your local independently operated Everpure dealer, or write Everpure for warranty and service information.



For sales, replacement components, and service, contact your Everpure dealer or:

Everpure, LLC: 1040 Muirfield Drive • Hanover Park, Illinois 60133 • 800.323.7873

In Europe: Toekomstlaan 30 • B-2200 Herentals, Belgium

In Japan: Hashimoto MN Bldg. 7F • 3-25-1 Hashimoto Sagamihara-Shi • Kanagawa 229-1103, Japan

Technical Service

800.942.1153

www.everpure.com