



Installation and Operation Guide

SR-X Scale Reduction Feeders

INTRODUCTION

The Everpure SR-X Scale Reduction Feeders are designed to efficiently dispense scale inhibiting products into foodservice water filtration systems. There are two versions. One (SR-X) is intended for cold water applications such as ice machines and replaces the previous Everpure IMF Feeder. The other (SR-X w/Delimiting Kit) is intended for hot water applications such as steamers and replaces the previous Everpure AR-X Feeder.

THE SR-X FEEDER (EV9798-45) INCLUDES:

- A clear bowl plastic housing
- An opaque head with integral mounting bracket
- An Everpure SS-IMF ScaleStick cartridge containing HydroBlend, a unique, specially blended compound that inhibits mineral scale deposits and provides corrosion protection for water-fed equipment.
- Two SS-IMF Spacers (adapts SS-IMF to 10" bowl)
- A sump wrench

THE SR-X FEEDER W/DELIMITING KIT (EV9797-20) INCLUDES:

- The same housing and head included in the SR-X Feeder.
- An Everpure SS-10 ScaleStick cartridge containing the HydroBlend compound.
- A check valve with pipe nipple (packed loose) to prevent backflow in hot water applications.
- One 2.2 lb. packet of Everpure ScaleKleen scale remover
- A dip-tube to convert the SR-X Feeder for use in introducing the ScaleKleen product.
- A sump wrench

NOTE: The SR-X and SR-X w/Delimiting Kit Feeders are supplied with different versions of ScaleStick cartridges. The SR-X Feeder includes the SS-IMF ScaleStick EV9799-32 which is shorter (approx. 7" in height) and contains less of the HydroBlend material than the SS-10 ScaleStick EV9799-02 (approx. 10" in height) included with the SR-X Feeder w/Delimiting Kit. The SS-IMF cartridge requires two 2-1/4" spacer (included with EV9798-45) which adapts it for use in the new, longer SR-X bowls.

SR-X SCALE REDUCTION FEEDER INSTALLATION

SR-X Feeders are provided in three forms:

1. As stand-alone feeders where their functions may be added to existing water consuming foodservice equipment installations.
2. As integral elements of standard Everpure water filter systems.
3. As add-on elements to standard Everpure water filter systems. The SR-X Feeders incorporate provisions for retrofitting onto new style Everpure multi-cartridge/multi-function filter systems to provide scale control as needed. Adaptation is accomplished by adding an optional post-feeder bracket to an existing system. Detailed installation instructions come with the post-feeder brackets.

Before starting the installation, be sure to shut off both power and water to the equipment being served. For servicing convenience, a manual shut-off valve should be installed in the water line ahead of the feeder.

IMPORTANT: Always use a NSF approved pipe dope or Teflon tape at all thread connections.
CONNECT TO INLET/FEED WATER MAKE-UP LINES ONLY. DO NOT CONNECT TO ICE MACHINE CONDENSER OR STEAMER CONDENSATE COOLING LINES

1. Select a suitable location for mounting the SR-X Feeder and install mounting screws 2 1/4" apart. If installing the EV9797-20 SR-X Feeder w/Delimiting Kit, assemble the 3/4" check valve and pipe nipple (provided loose) onto the outlet of the feeder head.
2. Un-thread the head assembly from the bowl.
3. Locate the ScaleStick cartridge in the carton and remove its shrink-wrapping.



SR-X Scale Reduction Feeder

4. **IMPORTANT!** If installing an SR-X Feeder using the SS-IMF ScaleStick cartridge (approx. 7" length), locate the two SS-IMF Spacers in the bowl. This is a short length (approx. 2¼") of ScaleStick cartridge bottom used to extend the length of the SS-IMF cartridge so that it fits securely into the 10" SR-X bowl. Insert the spacer into the bottom of the SS-IMF cartridge and proceed to the next step.
5. Insert the ScaleStick (black O-band seal at the top) onto the outlet stub on the bottom of the feeder head .
6. Check to be sure the o-ring on the bowl is clean and sufficiently lubricated and apply a high quality food grade silicone lubricant if more is needed.
7. Thread the bowl onto the feeder head with ScaleStick by hand while aligning the ScaleStick with the guide seat in the bottom of the bowl. Snug the bowl with the sump wrench (EV3112-41).
8. Connect the inlet water line to the inlet fitting connection on the SR-X Feeder head. Connect the SR-X outlet to the piping/tubing leading to the equipment being treated.
9. Continue with installation of the rest of the filter system, if the SR-X Feeder is being added on.
10. Turn on water to the SR-X Feeder and momentarily depress the red button on the head to purge air from the unit.

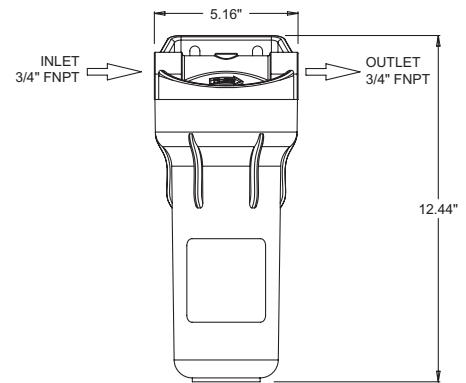

CARTRIDGE CHANGE INSTRUCTIONS

1. The SR-X Feeder bowls and ScaleStick cartridges are transparent, permitting continuous monitoring of product level. When the product level in the ScaleStick cartridge drops to within 1/2" from the bottom, the cartridge should be replaced.
2. Turn off inlet water to the feeder and momentarily depress the red button on the head to relieve pressure.
3. Un-thread the bowl from the head, empty water from the bowl and remove the used cartridge.
4. **IMPORTANT!** If changing cartridges in an SR-X Feeder using the SS-IMF ScaleStick cartridge (approx. 7" length), remove the SS-IMF Spacer from the bottom of the used cartridge and set it aside. Do not discard the spacer. Proceed to the next step.
5. Clean the bowl with a mild solution of unscented dishwashing detergent. **DO NOT** use soap, strong or scented detergents, chemical solvents or abrasives.
6. Remove the shrink-wrapping from the new ScaleStick cartridge.
7. **IMPORTANT!** If replacing an SS-IMF ScaleStick cartridge into an SR-X Feeder, reuse the SS-IMF Spacer set aside from Step 4. Insert the spacer into the bottom of the new SS-IMF cartridge and proceed to the next step.
Note: If the SS-IMF Spacer is missing or misplaced, a replacement spacer may be ordered. Alternatively, you may cut the bottom 2-1/4" from the used ScaleStick and use that portion as the spacer.
8. Insert the cartridge (black O-band seal at the top) onto the outlet stub on the bottom of the feeder head.
9. Check to be sure the O-ring on the bowl is clean and sufficiently lubricated and apply a high quality food grade silicone lubricant if more is needed.
10. Thread the bowl onto the feeder head with ScaleStick by hand while aligning the ScaleStick with the guide seat in the bottom of the bowl. Snug the bowl with the sump wrench (EV3112-41).
11. Turn on water to the SR-X Feeder and momentarily depress the red button on the head to purge air from the unit.

STEAMER DE-LIMING

- These instructions apply to the Everpure SR-X Feeder as well as to the previous AR-X Feeder.
 - Use only Everpure ScaleKleen™ scale remover product. Other harsh acids may damage bowl material and clog system orifices.
 - Use a one kilogram (2.2 lb) package to de-lime most countertop steamers.
 - Use four kilogram (2.2 lb) packages to de-lime most boiler-based steamers.
1. Turn off the power switch on the steamer.
 2. Blow down the steamer. Blow-down is done automatically on some steamers when power is turned off. Manually blow down the steamer if this is not done automatically.
 3. Turn off inlet water to the SR-X system.
 4. Depress the red button on the head to relieve system pressure.
 5. Unscrew the clear bowl and remove the used cartridge. Dispose of the exhausted cartridge in normal trash and empty any remaining water from the bowl.
 6. Locate the SR-X dip tube and insert the tube, O-ring first, into the center port of the head as far as it will go.
 7. Open a one kilogram (2.2lb) package of ScaleKleen and empty it into the bowl. Wipe off any excess ScaleKleen material which may be on the bowl threads or O-ring.
 8. Thread the bowl back into the SR-X head - hand tight only! NOTE: The dip tube end may become packed with ScaleKleen. This is normal and will not affect the de-liming procedure.
 9. Turn on the inlet water to the SR-X system.
 10. Turn on the power to the steamer. NOTE: This action will quickly introduce the ScaleKleen material directly into the boiler chamber. If you are de-liming a countertop steamer, proceed to step 11. If you are de-liming a boiler-base unit, monitor the ScaleKleen level in bowl. When the level drops to 1", quickly turn off the inlet water. Now relieve pressure and unscrew the bowl from the head. Add another kilogram of ScaleKleen to the bowl and reintroduce the material into the boiler. Repeat this procedure until four (4)

SPECIFICATIONS

Overall Dimensions:	12.44"H x 5.16"D
Shipping Weights:	2 lbs. (SR-X); 4.5 lbs. (SR-X w/ Deliming Kit)
Inlet/outlet Connections:	3/4" FNPT
Materials of construction:	
- Head:	polypropylene
- Clear bowl:	transparent plastic
Service Flow Rate:	0.5-6.0 gpm (1.9-22.5 lpm)
Pressure Limit:	125 psi (8.6 bar)
Temperature Limits:	35°F -100°F (2-38°C)

kilograms of ScaleKleen have been introduced into the boiler chamber. Proceed to step 11.

11. With ScaleKleen material introduced into the boiler chamber and the inlet water turned on, allow the steamer (countertop or boiler-base) to come up to operating temperature and pressure, and hold for one hour.
12. Thirty minutes into the de-liming procedure, turn on steam to cooking chamber(s) for one minute. This will de-lime the distribution lines, small orifices, and steam solenoid valves.
13. After one hour of de-liming the steamer at operating temperature and pressure, turn the steamer power switch off.
14. Manually blow down the steamer if it is not done automatically when the power is turned off.
15. Fill the boiler with fresh, clean water and repeat blow down a second time to void the boiler chamber of any un-dis-solved loose scale. Thoroughly rinse the cooking compartment(s) with cold water and wipe dry with a clean, soft towel.
16. After the second blow-down, turn the steamer power switch off, and turn off the water to the SR-X Feeder.
17. Relieve system pressure by depressing the red button on the SR-X head until all air is purged and water begins to escape.
18. Unscrew the bowl and remove the dip tube from the head. BE SURE TO PLACE THE DIP TUBE IN A CONVENIENT LOCATION.
19. Install a new SS-10 cartridge into the head and thread the bowl back onto the head. Snug the bowl with the sump wrench (EV3112-41).
20. Turn on the inlet water. Relieve any trapped air in the bow by depressing the red button on the SR-X head until all air is purged and water starts escaping.
21. Turn the steamer power switch on. The steamer is now ready to be placed back into service.
22. Be sure to order additional SS-10 replacement cartridges, ScaleKleen and carbon filter cartridges to maintain future worry-free operation of your steamer.

REPLACEMENT PARTS

Contact your local Everpure dealer for filter cartridges or system replacement parts.

Description	Part Number
Head	EV3112-37
O-ring	EV3112-40
10" bowl, clear	EV3112-39
Sump wrench	EV3112-41
SS-IMF 7" ScaleStick (12-pack) for SR-X	EV9799-32
SS-IMF spacer	EV3114-69
SS-10 ScaleStick (12-pack) for SR-X w/Deliming Kit	EV9799-02
Dip tube for SR-X Deliming Kit	EV3080-40
3/4" outlet check valve for SR-X w/Deliming Kit	EV3114-50

LIMITED WARRANTY

COMMERCIAL WATER TREATMENT EQUIPMENT

You have just purchased one of the finest water treatment units made. As an expression of our confidence in Everpure products, this product is warranted against defects in material and workmanship to the original end-user when installed in accordance with Everpure specifications. The warranty period commences from the date of purchase and is administered as follows:

For a period of ONE YEAR

Replaceable elements (i.e., filter & water treatment cartridges)*

For a period of FIVE YEARS

The entire system (excluding replaceable elements)

***This is for material & workmanship, not filter or water treatment cartridge life.**

The unit must be used in operating conditions that conform to Everpure's recommended design guidelines. This warranty will not apply if the unit has been modified, repaired or altered by someone not authorized by Everpure.

If a part described above is found defective within the specified period, you should notify Everpure technical service at the phone number listed below. Any part found defective within the terms of this warranty will be repaired or replaced (at Everpure's discretion) by your local dealer or Everpure technical service. You pay only freight from our factory and local dealer charges. Any repaired or replaced warranty item will be incorporated under the original warranty terms of the existing system.

We are not responsible for damage caused by accident, fire, flood, freezing, Act of God, misuse, misapplication, neglect, oxidizing agents (such as chlorine, ozone, chloramines and other related components), alteration, installation or operation contrary to our printed instructions, or by the use of accessories or components which do not meet Everpure's specifications. Refer to the specifications section in the Installation and Operating manual for approved application parameters.

Our product performance specifications are furnished with each water treatment unit. TO THE EXTENT PERMITTED BY LAW, EVERPURE DISCLAIMS ALL IMPLIED WARRANTIES, INCLUDING WITHOUT LIMITATION WARRANTIES OF MERCHANTABILITY AND FITNESS FOR PARTICULAR PURPOSE; TO THE EXTENT REQUIRED BY LAW, ANY SUCH IMPLIED WARRANTIES ARE LIMITED IN DURATION TO THE PERIOD SPECIFIED ABOVE FOR THE ENTIRE WATER TREATMENT UNIT. As a manufacturer, we do not know the characteristics of your water supply or the purpose for which you are purchasing this product. The quality of water supplies may vary seasonally or over a period of time, and your water usage rate may vary as well. Water characteristics can also differ considerably if this product is moved to a new location. For these reasons, we assume no liability for the determination of the proper equipment necessary to meet your requirements, and we do not authorize others to assume such obligations for us. Further, we assume no liability and extend no warranties, express or implied, for the use of this product with a non-potable water source or a water source which does not meet the conditions for use described in the owner's guide or performance data sheet for this product. OUR OBLIGATIONS UNDER THIS WARRANTY ARE LIMITED TO THE REPAIR OR REPLACEMENT (AT EVERPURE'S DISCRETION) OF THE FAILED PARTS OF THE WATER TREATMENT UNIT, AND WE ASSUME NO LIABILITY WHATSOEVER FOR DIRECT, INDIRECT, INCIDENTAL, CONSEQUENTIAL, SPECIAL, GENERAL OR OTHER DAMAGES.

Some states do not allow the exclusion of implied warranties or limitations on how long an implied warranty lasts, so the above limitation may not apply to you. Similarly, some states do not allow the exclusion of incidental or consequential damages, so the above limitation or exclusion may not apply to you. This warranty gives you specific legal rights, and you may also have other rights which vary from state to state. Consult your telephone directory for your local independently operated Everpure dealer, or write Everpure for warranty and service information.



For sales, replacement components, and service, contact your Everpure dealer or:

Everpure, LLC: 1040 Muirfield Drive • Hanover Park, Illinois 60133 • 800.323.7873

In Europe: Toekomstlaan 30 • B-2200 Herentals, Belgium

In Japan: Hashimoto MN Bldg. 7F • 3-25-1 Hashimoto Sagamihara-Shi • Kanagawa 229-1103, Japan

Technical Service

800.942.1153

www.everpure.com