

SPEC # \_\_\_\_\_

QUANTITY \_\_\_\_\_

### APPLICATION

## MULTIPLE EQUIPMENT



### AT A GLANCE

The Aqua-Pure<sup>®</sup> DF290-CL Dual-Flow water filtration systems assure consistent high-quality water for the multiple applications of cold beverages and ice at a combined flow rate of up to 7.66 gpm (29.1 lpm). Two separate streams exit the manifold. The first stream (STREAM ONE) supplies cold beverage applications. The second stream (STREAM TWO) supplies the ice machine.

- **STREAM ONE** combines cyst, bacteria, chloramine, chlorine taste and odor, and sediment reduction for a total volume up to 30,000 gallons (113,563 liters) at a flow rate up to 2.66 gpm (10.2 lpm).
- **STREAM TWO** reduces cyst, bacteria, and sediment. The flow rate is up to 5 gpm (18.9 lpm), and the life is 30,000 gallons (113,563 liters). Chloramine and/or Chlorine are not removed from this stream to preserve their disinfectant properties. A scale-inhibition medium is added to reduce the hard-scale effects of calcium and magnesium ions.

### PRODUCT BENEFITS

- One system for dedicated Ice and Cold Beverage applications that simultaneously supplies high-quality water for beverage dispensers and ice machines.
- Revolutionary IMPACT<sup>™</sup> dual-zone media cartridge construction combines a membrane in series with premium activated carbon to provide unsurpassed throughput and cartridge life for beverage applications.
- Cartridge Life Warranted\*
- Certified by NSF to Standard 53 for cyst reduction.
- NSF Standard 42 and/or FDA CFR 21 compliant materials provide assurance of safety.
- The removal of water-borne heterotrophic bacteria by membrane filtration as tested by CUNO.
- A dedicated non-carbon-containing cartridge removes only sediment and adds a scale-inhibition medium for ice machines. The inlet-water's chlorine/chloramine content is unaffected for the reduction of biofilm.
- SQC<sup>™</sup> - Sanitary Quick Change - encapsulated cartridge design allows for fast and easy change-outs with a ¼ turn while minimizing the possibility of leakage and contamination.
- 3/4" FNPT plumbing connections allow direct or easily-adaptable connections to existing plumbing lines.
- Auxillary inlet gauge port allows optional monitoring of differential water pressure.
- Exhausted cartridges may be incinerated for environmentally-conscious disposal.

### PRODUCT SPECIFICATIONS

Model	Part Number	Reduction Claims	Micron Rating	Capacity	Service Flow Rate	Application	Replacement Cartridge	Sizing
DF290-CL	56170-02	Cyst, Bacteria, Sediment, Chloramine, Chlorine Taste and Odor, Scale	0.2'	Bev Stream: 30,000 Gallons (113,563 Liters) Ice Stream: 30,000 Gallons (113,563 Liters)	Bev Stream: 2.66 gpm (10.2 lpm) Ice Stream: 5 gpm (18.9 lpm)	Most Normal Water	DF290-CL CARTPAK: 56138-07	For simultaneous operation of carbonators and ice machines.

\* See Aqua-Pure Commercial Products Price Book for Terms and Conditions

† NSF Certified for Particulate, Class I

# Aqua-Pure® Commercial Products

SPEC # \_\_\_\_\_

QUANTITY \_\_\_\_\_

MODEL NUMBER \_\_\_\_\_

PART NUMBER \_\_\_\_\_

# Aqua-Pure®

COMMERCIAL PRODUCTS

## DF290-CL

### PHYSICAL SPECIFICATIONS

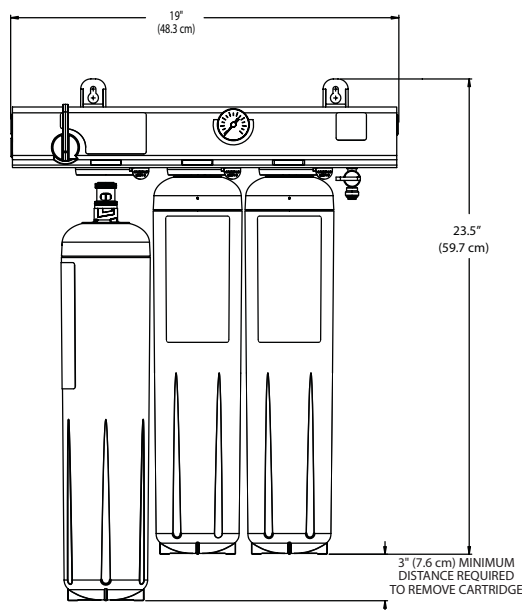

- System includes a three-cartridge dual-outlet port manifold with built-in pressure gauge, optional port for an inlet pressure gauge, inlet water shut-off valve, outlet check valve, mounting brackets, and the cartridge filters.
- Inlet and outlet plumbing connections to the mounted head are 3/4 inch FNPT.
- Filter cartridges are double o-ring seal type.
- System maximum operating pressure of 125 psi (862 kPa) and operating temperature of 100°F (38°C).
- Recommended total service flow rate is up to 7.66 gpm (29.1 lpm) (see Product Specifications for individual flow max.)
- Beverage filter cartridges incorporate carbon block media protected by a pleated pre-filter membrane. Ice filter cartridge includes a filter membrane and scale-inhibition media.
- System is NSF Standard 42 and/or FDA CFR21 compliant.
- Cartridge bodies are constructed from high-impact glass-filled polypropylene.
- Cartridges are sanitary in design, requiring no contact with the filter media during cartridge change-out.
- Filter cartridges require no pre-activation.
- A NSF Performance Data Sheet (PDS) is included.
- Shipping weight: 20 lbs (9.1 kg)
- Operating weight: 38 lbs (17 kg).

Do not use with water that is microbiologically unsafe or of unknown quality without adequate disinfection before or after the system. Systems certified for cyst reduction may be used on disinfected water that may contain filterable cysts. EPA Establishment Number 070595-CT-001.

CUNO Incorporated recommends regularly scheduled maintenance and replacement of the filter cartridge(s) in order for the product to perform as advertised/sold. Change the filter cartridge at least every 6 months. CUNO shall not be liable for system failures due to improper maintenance.

### INSTALLATION TIPS

- Shut off downstream equipment prior to installation of the system.
- Choose mounting location to support full system weight when operating.
- Do not exceed operating parameters for temperature or pressure.
- Do not install outdoors.
- For commercial use only with cold water.

### LIMITED 5 YEAR WARRANTY

CUNO Incorporated warrants to the original purchaser-consumer that this product is free from defects in materials and workmanship. This warranty, together with any and all warranties implied by law, shall be limited to a period of five (5) years from the date of original purchase by the consumer. This warranty does not apply to failures that result from abuse, misuse, alteration or damage not caused by CUNO. This warranty is subject to exclusions and limitations. Please refer to the Warranty Card provided with the product for details.

### SERVICE WORLDWIDE

#### CHINA

CUNO Filtration Shanghai Co. Ltd.  
No. 2 Plant East Side  
Xin Miao San Road  
XinQiao Town SongJiang District  
Shanghai, China 201612

#### JAPAN

CUNO K.K.  
Hodogaya Station Building 6F  
1-7, Iwai-Cho, Hodogaya-Ku  
Yokohama 240-0023, Japan

#### AUSTRALIA

CUNO Pacific Pty Ltd.  
140 Sunnyholt Road  
Blacktown, N.S.W. 2148  
Australia

#### BRAZIL

CUNO Latina Ltda  
Rua AMF do Brazil - 251  
18120 Mairinque-SP, Brazil

#### EUROPE

CUNO Limited  
21 Woking Business Park  
Albert Drive  
Woking, Surrey  
GU21 5JY, England

#### SINGAPORE

CUNO Filtration Asia Pte Ltd  
2A Tuas Avenue 12  
Singapore 639023



Visit [www.nsf.org](http://www.nsf.org) for the claims associated with products that are NSF listed.



### CUNO Incorporated

400 Research Parkway  
Meriden, CT 06450, USA  
Toll Free: 1.888.218.CUNO  
Worldwide: 203.237.5541  
Fax: 203.238.8701  
[www.cunofoodservice.com](http://www.cunofoodservice.com)