

# Doulton®

## Supercarb Ceramic Filter Cartridges

*Doulton® has been a leading name in drinking water filtration for over 150 years.*

*Doulton® ceramic elements are now available in a range of standard cartridge formats which bring the quality associated with the Doulton® name to the general filtration market.*

# Supercarb

## Features

- Fits Industry standard 10" and 20" filter housings
- Dual stage filtration within a single cartridge
- Filtration efficiency of > 99.99% at 0.9 micron
- Filtration efficiency of > 99.9% at 0.5 to 0.8 micron
- Highly efficient bacteriological filtration
- Tested with live Cryptosporidium to a removal efficiency >99.999%
- Ideal for R O guard and post filtration
- Complimentary to UV systems
- High levels of Chlorine and organics removal



## Supercarb Cartridges

The Doulton Supercarb is a two stage cartridge combining the highly efficient filtration properties of ceramic with the enhanced water treatment properties of activated carbon.

### First Stage

The first stage consists of Doulton Sterasyl® ceramic which is manufactured to provide genuine sub micron filtration. The cartridge reduces fine particulate matter, bacteria, cysts and turbidity. The incorporation of silver locked within the ceramic structure gives enhanced bacteriostatic and self sterilising properties.

### Second Stage

An inner core of activated carbon block removes chlorine and organic compounds.

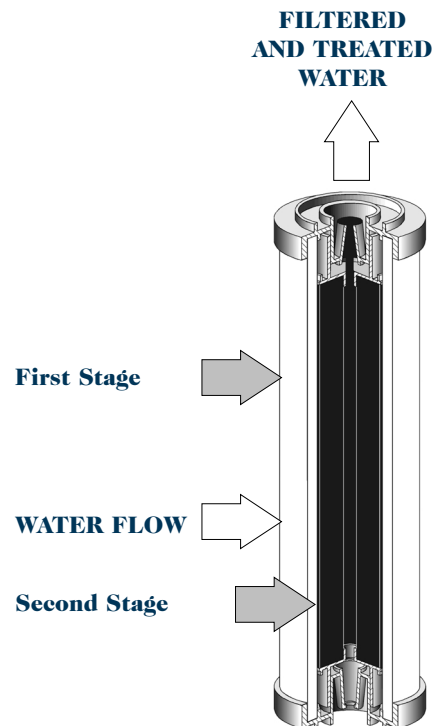

# Doulton®

## Filtration Data Sheet

### Filtration Efficiency

Absolute filtration rating	(defined as > 99.99%)	0.9 micron
Nominal filtration rating	(defined as 99.9%)	0.5 - 0.8 micron
% Bacteria removal	E.coli	> 99.99%
	Vibrio Cholera	> 99.99%
	Shigella	> 99.999%
% Cyst removal	Salmonella Typhi	> 99.999%
	Klebsiella Terrigena	> 99.99%
	Cryptosporidium	> 99.999%
	Giardia	> 99.999%

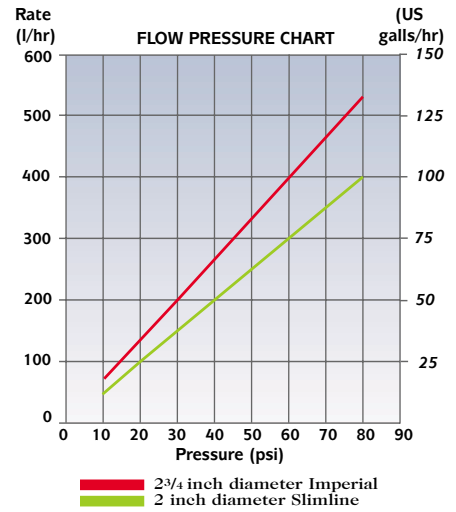

### 20 Inch Filter Housings

Supercarb Imperial (2 3/4") Filter cartridges can be supplied with a second adaptor cartridge to allow fitting in 20 inch filter housings. Due to slight variations in housing design, please state housing manufacturer when ordering.

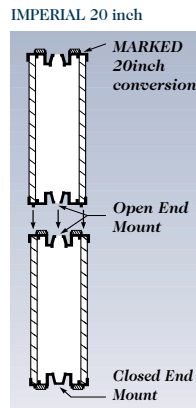

### Chlorine Reduction (@ 2ppm challenge)

	Volume capacity @ >97% removal efficiency	
	Litres	US Gallons
<b>Slimline</b> 9 1/2 x 2" (tested @ 1.7 L/min flow rate)	4000	1000
<b>Imperial</b> 9 1/2 x 2 3/4" (tested @ 3.8 L/min flow rate)	8000	2000

### Trace Organics Removal

Insecticides	Lindane @ 0.1 ppb presence	> 85%
Herbicides	Atrazine @ 1.2 ppb presence	> 85%
Phenols	TCP @ 1.2 ppb presence	> 50%
Polyaromatic Hydrocarbons	PAH's @ 0.2 ppb presence	> 95%
Trihalomethanes	Chloroform @ 150 ppb presence	> 50%

(3000 litre challenge).

### Cartridge Dimensions

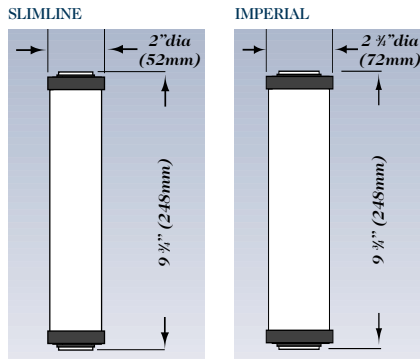

### Cartridge Shipping Specification

	Individual cartridge weight	Quantity per outer carton	Outer carton gross weight
Slimline 9 1/2 x 2"	0.3 kg	25	9 kg
Imperial 9 1/2 x 2 3/4"	0.55 kg	9	7 kg

Standard carton size 33 x 33 x 34 cm

### Product Specification

Working temperature range	5 - 38°C
Working pH range	5.5 - 9.5
Minimum working pressure	10 psi
Maximum working pressure	125 psi

Due to a policy of continuing product development Fairey Industrial Ceramics Limited reserves the right to change any information without prior notice.

Doulton® water filters are manufactured by Fairey Industrial Ceramics Ltd

Doulton® and Sterasyl® are registered trademarks of which Fairey Industrial Ceramics Limited is an authorised user.



BS EN ISO 9002: 1994  
Certificate Number: 90082



Distributed by:

**Doultonusa.com**

1.888.664.3336 in US

248.258.5500 int'l