



Installation and Operation Guide For AquaGate CX

Limited Warranty

Water Controller Products Inc. (WCP) has carefully tested and inspected the AquaGate™ before shipment, and hereby warrants our products to be free of defects in material and workmanship for a period of 2 years from the date of the original purchase. You should replace your ball valve every 10 years since it is in constant contact with your water supply.

During the warranty period WCP shall, at its sole and absolute discretion, either repair or replace free of charge any of our products that prove to be defective on inspection by WCP or its authorized service representative. This warranty does not cover claims for damage due to abuse, neglect, alteration, or attempted repair by unauthorized personnel, and is limited to failures arising during normal use that are due to defects in material or workmanship in the product.

ANY IMPLIED WARRANTIES, INCLUDING IMPLIED WARRANTIES OF MERCHANTABILITY AND FITNESS FOR A PARTICULAR USE AS SET FORTH IN THESE INSTRUCTIONS, ARE LIMITED IN DURATION TO THE LENGTH OF THIS LIMITED WARRANTY. USE OF THIS PRODUCT IS NOT A REPLACEMENT FOR YOUR INSURANCE POLICY. IN NO EVENT WILL WCP BE LIABLE FOR INCIDENTAL, CONSEQUENTIAL OR OTHER DAMAGES RESULTING FROM THE BREACH OF ANY EXPRESS OR IMPLIED WARRANTY, INCLUDING, AMONG OTHER THINGS, DAMAGE TO PROPERTY, DAMAGE BASED ON INCONVENIENCE OR ON LOSS OF THE USE OF THE PRODUCT, AND, TO THE EXTENT PERMITTED BY LAW, DAMAGES FOR PERSONAL INJURY. THE LIABILITY OF WCP SHALL BE LIMITED TO REPLACEMENT OF THE DEFECTIVE PRODUCT.

This warranty only applies to products sold and used in North America. For warranty information in all other countries, please refer to your local distributor.

Precautions

- Use of the AquaGate™ is restricted to indoor water supply lines in home, office or industrial applications.
- Do not allow small children to play with the controller, their fingers could get stuck or injured inside of the controller valve. Only insert a pipe, tube or a fitting of the proper size into the controller valve.
- Operate the unit only with “AA” size alkaline type batteries.
- Do not disassemble the valve and actuator assembly. If you have, connect the actuator to the circuit board, press open, and then reassemble the valve actuator assembly. Test to verify the valve fully closes.
- Keep chemicals, acids, and organic solvents away from the controller and sensor.

1 INSTALLATION Step 1: Inserting the Batteries

A) Opening the controller: Open the front cover door by lightly pressing down on the front of the top cover hook.

B) Connecting the valve wires: Insert the black valve wire into the “valve -” screw terminal on the circuit board, and turn the terminal screw clockwise to secure the black valve wire. Repeat this process with the red valve wire and the “valve +” screw terminal on the circuit board. The valve is now connected.

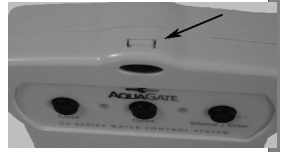

Take this moment to record the installation date on the inside of the battery door, and on the space below:

Original Battery Installation Date: _____

Additional Battery Change Dates: _____

C) Battery connection: Insert the 4 “AA” alkaline batteries into the battery holder slots, matching the positive (+) and negative (-) terminals as marked.

* The valve will close half way, and return to the open position, and the blue LED light will flash 3 times, and you will hear the speaker chirp 3 times.

D) Reattach the cover: Insert the bottom of the front cover onto the bottom of the back of the controller, and push the top of the front cover back onto the cover hook.

2 Step 2: Test the Controller

VERY IMPORTANT:

DO NOT INSERT ANYTHING INSIDE THE VALVE WHILE IT IS NOT CONNECTED AND INSTALLED IN A WATER SUPPLY.

SERIOUS INJURY OR VALVE DAMAGE WILL OCCUR!

Open the valve by pressing the open button on the controller. The green light will flash until the valve is open. Now the controller is open and loaded. Press the left close button. The red light will flash until the valve is closed. Press the open button again to open the valve.

Put a coin into the sensor or put a small amount of water on the sensor. The valve will close sounding the alarm and flashing the LED 4 times continuously. After the valve is closed and the red light goes off, open and reset the valve by pressing the open button. The system is now ready for installation. Now the controller is confirmed to be working properly and is ready to be mounted and the valve connected to your water supply.

3 Step 3: Preparing the Water Source

Do not install the AquaGate™ valve ahead, or upstream (in front of) a fire sprinkler system. This violates every municipal code, and as such is illegal! Use a licensed plumber.

The preferred installation of the AquaGate™ would include the use of unions before and after the valve. All soldering of connectors should be done prior to the valve being connected, as heat from soldering can damage the seals of the valve and invalidate the warranty.

Getting Started:

Package contents:

1ea main AquaGate™ controller module

1 ea 15-foot sensor cable

1ea 1” motorized ball valve with 2 wire connector

4ea “AA” size alkaline batteries

4ea #8 mounting screws

1ea Sensor mount with adhesive backing to secure sensor wiring

1ea Quick reference label

* Additional sensors and cable lengths may be ordered

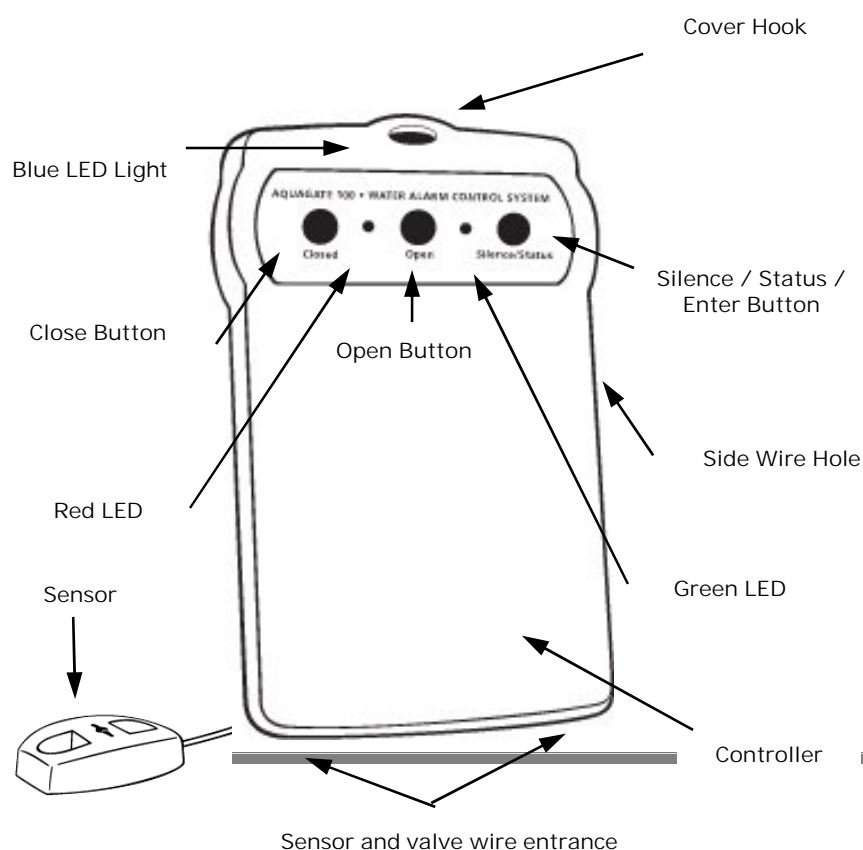

Quick Reference

◆ **The AquaGate is beeping, how do I silence it?**

Press any button

• **The Leak Controller has activated due to one of the following:**

1. water touching the sensor (leak or spill) (4 Blue LED flashes)
2. low battery (2 Blue LED flashes)
3. maintenance mode (1 Blue LED flash)

Check for leaks and fix if necessary. Dry sensor(s). Change the batteries if in doubt. Press the middle (Open) button to open the valve

Now the AquaGate is in the normal open and ready position again.

Lights:

Green = Valve Open Red = Valve Closed

4 Step 4: Attaching the Valve to your plumbing supply line

Have a professional licensed plumber install the threaded ball valve to the copper piping as described in step #3.

We recommend that you have a shut off valve upstream of the AquaGate™. Close this valve prior to installation.

Do not grip the actuator motor assembly during installation as damage may occur. Do not open the actuator and valve assembly as this will void the warranty.

5 Step 5: Mounting the Controller Box

Locate a clean, flat wall surface that is within 10' of the valve. Remove the cover of the controller as described in section #1.

Use a marker to mark on the wall where the 4 screws will be installed by inserting the marker through the 4 mounting holes. Insert the 4ea #8 screws through the back of the controller box, and into the wall for a secure installation. If the wall is made of drywall, then use the 4 drywall anchors supplied with the product.

Confirm that the box is secure and all wiring to the valve, sensors, power, external interface is secure.

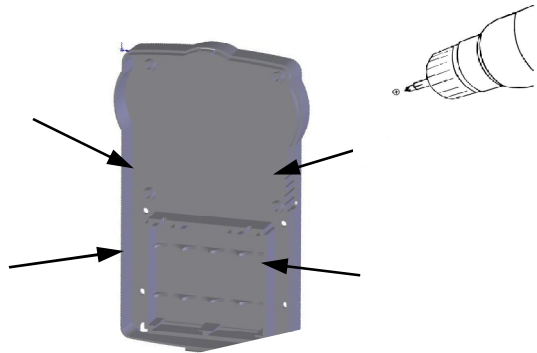

6 Step 6: Connecting and Placing the Sensors

This is a very important part of the installation. The sensor is the heart of the controller, and if water doesn't touch the sensor it will not activate. Also, it is extremely important that the metal side of the sensor always remains facing down after the installation.

Connecting the sensor: To connect the sensor to the circuit board, gently push the female connector at the end of the sensor cable onto any one of the 2 pin gold male connectors marked "sensor" on the circuit board.

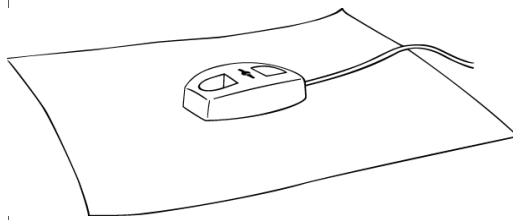

Placing the sensor: To confirm the path of the water in the event of a leak, take a plate or flat pie tin and place it near where the sensor will be placed. Pour some water onto the plate and check the direction of the flow. Adjust the sensor's position accordingly to this flow path to make sure, in the event of the leak, the water flows

towards the sensor.

Once you have confirmed the sensor location, you can place the sensor on an absorbent material such as an ordinary paper towel to increase the detection of small leaks.

Adding sensors: Additional sensors may be added to your system in two ways: 1) In series: To connect a second sensor in series, push the connectors at the end of the second sensor cable onto the metal connectors located under the first sensor. Route the separate wires around the bottom part of the sensor and out the other end of the sensor. 2) To connect a second, third and or fourth sensor, simply insert the sensor connector onto the circuit board sensor connection.

To confirm that the second sensor is working properly, insert a coin or screwdriver into the sensor slots, this should replicate a leak and activate the alarm feature on the controller. To reset the controller, see Step 7.

* Please note that for the sensors to work, the leak does not have to enter the slots on top of the sensors. This may happen, but the sensors also detect surface moisture via the sensor probes on the bottom of the sensor.

7 Step 7: Checking & Testing the Controller

There are two ways to check the system:

1. Check the Controller (see Step 2).
2. Testing at the Sensor. To test that your sensor and controller are working properly, simply wet your finger and touch both sensor probes. This replicates a leak condition, the controller will close the valve, sound the alarm, and flash the red LED.

To reset the system return the valve to the green position.

The controller should be tested **every month**, at the sensor(s) to confirm the system operation. Every month examine each sensor to confirm that it is laying metal side down on the sensor mat, and wipe the bottom of the sensor metal strips with a dry cloth.

Maintenance

Replace all four batteries with "AA" Alkaline type batteries:

- a) **Bi-Annually (every other year)**
- b) If the alarm has been sounding for an undetermined length of time
- c) If the low battery alarm chip is sounding (2 flash and 2 beep)

Since the controller is in constant contact with your water supply, **the maximum life expectancy of the controller is ten years.** Although you may achieve longer use of the controller depending on the quality of your water source, we recommend that do not exceed this time period.

Service Reminder

The controller may be set for a service reminder indication. This is done for a reminder to maintain the system or systems connected to the controller.

To Set: Press and hold the enter button while simultaneously pressing the closed (left) button. Keep holding the buttons until the unit is flashing and beeping once repeatedly (or the current reminder setting). Let go of the buttons and press the Closed button to cycle through the service reminder stages:

- ➔ 1 flash and beep: Service Reminder Off
- ➔ 2 flashes and beeps: Service Reminder 6 months
- ➔ 3 flashes and beeps: Service Reminder 12 months
- ➔ 4 flashes and beeps: Service Reminder 18 months

When the unit is flashing the desired service reminder stage, press the Open button to set the service reminder.

To reset or cancel the service reminder, enter service reminder mode (above) and change the flashes to the desired stage.

Operation

Automatic Operation

Other than the recommended maintenance outlined above, your AquaGate™ will operate automatically. In the event that the sensors detect a leak, the controller will close the valve to the red position, and sound an alarm.

Low Battery

If the circuitry detects a low power response from the batteries, the controller will beep and flash 2 times until new batteries are installed. **If the batteries are not replaced the valve will stay open.**

Manual Valve Close

The controller's valve can also be shut manually. To do this, push the CLOSE button located on the left of the controller. To rearm the controller and open the valve, press the OPEN button.

Fold and place these instructions behind the mounted controller for convenient reference.

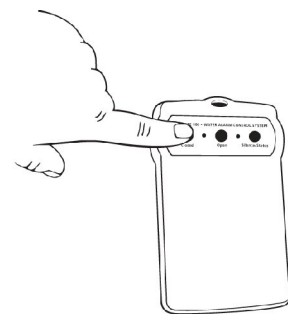

Specifications

Full Port Ball Valve	Power output: 6V
0-180 p.s.i. Pressure rating	Battery Life: 2 years (normal condition)
33° - 140°F (1°-60°C) Temperature rating	Weight: 3.0 lbs with batteries
Power: 4 x "AA" Alkaline Batteries	Size: 6.75" (h) x 3.25" (w) x .5" (d)

Operations / Troubleshooting Guide

We have the following matrix to help you quickly identify the most common conditions that exist with your AquaGate™. In the event that you are still having problems with your product after consulting this guide, please contact us at www.watercontrollerinc.com so we can be of immediate assistance to you.

Press the SILENCE / ENTER button to confirm if the valve is open or closed. The green LED will light for open and the red LED will light for closed.

- * Please note that whenever the valve closes to the red position (except when testing), **you must do the following:**
 - 1) Confirm that the batteries are working correctly
 - 2) Check and test the sensor and controller
 - 3) Look for leaks, it is possible that you had a leak and it has dried

Operations / Troubleshooting Matrix

Condition	Led Valve Status	Blue LED Light	Speaker	Sensor	Battery	Recommended Action
Normal/ Armed	Off	Off	Off	Dry	Good	TEST and examine sensor(s) when needed (at least monthly) Press enter button to confirm unit in operation.
LEAK	Red	4 Flashing (b)	On (b)	Wet or Dry	Bad	Examine the Sensor(s), Fix the leak, dry sensor(s), change mat (if used), change batteries.
Low Battery Mode #1	Green or Red (after 3 days beeping)	Flashing or Off (a) 2 Flashes	On or Off (a) 2 Beeps	Dry	Bad	Change batteries, then test at sensor (Step #7)
Low Battery Mode #2 Valve did not shut	Green	Flashing or Off (a) 8 Flashes	On or Off (a) 8 Beeps	Dry	Bad	Battery has gone into final shut-down mode as the batteries are almost dead. This 8 flash mode indicates that the valve may not be able to close.
Service Reminder	Green	1 Flash every 3 seconds	On or Off (a) 1 Beep	Dry	Good or Bad	The unit has been programmed for service reminder mode. (See SERVICE REMINDER for reset (above))

(a) The LED's may not be working due to the batteries dying. Any alarm mode the controller will flash and beep until the system is reset or until the battery dies.

(b) On LEAK condition, the controller will continually flash and beep 4 times together until it is silenced by pressing any Button. The blue LED will continue to flash until the valve is opened and the sensor is dry.

ALWAYS CHECK THE SENSOR(S)

