

EVERPURE® WATER BLOCK AND OPTIONAL WATER BLOCK RESET DEVICE

OFFICE FLOOD PROTECTION AND PEACE OF MIND FOR ABOUT THE COST OF AN AIRPOT

Water Block: EV9503-00



Optional Water Block Reset Device: EV9503-20



APPLICATIONS

- Coffee
- POU Coolers
- Undercounter Chillers
- Undercounter Instant Hot Water Heaters
- Vending
- Small Ice Machines

BENEFITS • FEATURES

Overflow safety device controls the maximum consumption of water between 1.3 and 13.2 gallons (4.9 and 49.97 L)

Device measures the number of gallons of water that have passed through it; if this quantity exceeds the set value, the Pentair Everpure Water Block stops the flow and maintains this safety condition until user intervention

If the water volume does not exceed the set value, the Pentair Everpure Water Block mechanically and automatically resets the measured volume and is ready to restart a new measurement cycle

No external energy source required – water simply flows through device

Resistant to chlorine and chloramines damage

INSTALLATION TIPS

Vertical assembly preferred

Not recommended for reverse osmosis installations

Use of the optional EV9503-20 Water Block External Reset device is recommended

Use of the optional EV3138-61 Adaptor is recommended for installation with GHT connectors

244454 clip can be used for mounting during installation

OPERATION TIPS

Maximum volume established by 10 setting notches

Every notch increases the set volume by 1.5 +/- gallons (5 +/- liters)

EVERPURE® WATER BLOCK

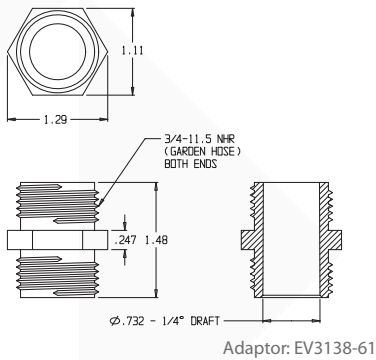
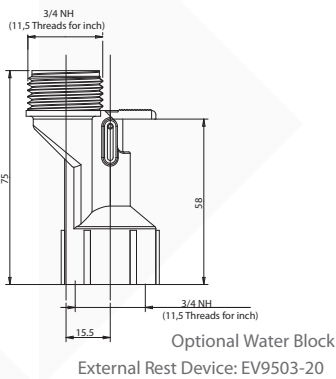
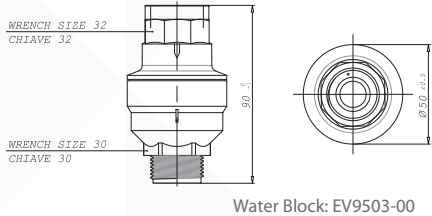

SPECIFICATIONS

Dimensions

3/4" threaded female connection
(North America GHT / Europe BSP)

3/4" threaded male connection
(North America GHT / Europe BSP)

Pressure Requirements

10 - 125 PSI (0.7 - 8.6 bar)

Ambient Temperature

35 - 140°F (2 - 60°C)

Fluid Temperature

35 - 158°F (2 - 70°C)

Flow Rate

0.53 - 7.9 GPM (2 - 30 Lpm)

Resistance to Bursting

725.19 PSI at 77°F (>50 bar at 25°C)

Related Lifespan

> 79,000 gal (300,000 L)

Electrical Connection

None required

WARRANTY

Pentair warrants that the Everpure Water Block device will be free of defects in materials and workmanship for a period of ninety (90) days from proof of purchase. If a device malfunctions, it must be returned to Everpure for evaluation. If the unit is found to be defective, it will be replaced at no charge. Pentair's warranty does not apply to defects resulting from any action of the purchaser, including but not limited to mishandling, improper adjustment or installation, operation outside recommended design limits, improper repair or maintenance or unauthorized modification. This warranty is VOID if the device shows evidence of having been tampered with or shows evidence of being damaged by the purchaser in any way.

