



**PENTAIR<sup>®</sup>**  
**FRESHPOINT<sup>®</sup>**  
**ULTRAFILTRATION SYSTEM**  
**APPLICATIONS GUIDE**

# TABLE OF CONTENTS

|  |   |  |
|--|---|--|
| <p><b>2 USING THIS GUIDE</b></p> <p><b>3 HOW ULTRAFILTRATION WORKS</b><br/>MEMBRANE CONSTRUCTION<br/>FILTRATION OPERATION<br/>FLOW DIRECTION</p> <p><b>5 ULTRAFILTRATION APPLICATIONS</b></p> <p><b>6 WATER QUALITY BASICS</b><br/>WATER SOURCES<br/>SEASONAL VARIATIONS<br/>WATER IMPURITIES<br/>WATER ANALYSIS</p> <p><b>7 FEED WATER QUALITY AND PRETREATMENT REQUIREMENTS</b><br/>GENERAL FEED WATER<br/>SURFACE WATER<br/>WELL WATER<br/>PURE WATER</p> <p><b>9 FILTERED WATER QUALITY</b><br/>TYPICAL FILTERED WATER QUALITY</p> | <p><b>9 SYSTEM SIZING</b><br/>MEMBRANE FLUX RATES<br/>TEMPERATURE CORRECTION FACTOR</p> <p><b>10 OPERATING GUIDELINES</b></p> <p><b>11 SYSTEM CONFIGURATIONS</b><br/>AUTOMATIC FLUSHING OPERATION<br/>STORAGE TANKS</p> <p><b>13 SHIPPING AND HANDLING</b><br/>CAREFUL TRANSPORT AND HANDLING<br/>STORAGE</p> <p><b>13 SYSTEM STARTUP GUIDELINES</b><br/>PIPING<br/>FLUSHING<br/>SYSTEM DISINFECTION</p> <p><b>13 MEMBRANE RINSING</b></p> <p><b>14 SYSTEM SANITIZING</b></p> | <p><b>15 MEMBRANE INTEGRITY TEST</b><br/>GENERAL TEST INFORMATION<br/>EQUIPMENT<br/>PROCEDURE</p> <p><b>16 MEMBRANE CLEANING</b><br/>MONITORING MEMBRANE PERFORMANCE FOR FOULING<br/>NORMALIZING FLOW DATA BEFORE CLEANING<br/>CLEANING PROCEDURE</p> <p><b>18 MEMBRANE STORAGE AFTER USE</b></p> <p><b>18 BASICS OF FOULING</b></p> <p><b>19 ULTRAFILTRATION TERMS</b></p> <p><b>20 FREQUENTLY ASKED QUESTIONS</b></p> <p><b>22 TROUBLESHOOTING GUIDE</b></p> <p><b>23 MEMBRANE DATA SHEET FRESHPOINT® MODEL U440</b></p> |
|--|---|--|

## USING THIS GUIDE

This guide is intended to provide general guidance to users regarding installation, operation, and maintenance of ultrafiltration systems including:

- Applications
- Feed water requirements
- Pretreatment requirements
- System sizing
- Performance
- Membrane maintenance

This guide is intended for use by water treatment professionals who have some familiarity with membranes used for water treatment. It is recommended for users to have completed the WQA® Reverse Osmosis/Ultrafiltration Specialty Exam, or have equivalent experience with membrane treatment basics.

For detailed information on specific ultrafiltration systems, please refer to its corresponding operating and maintenance manual and product data sheet.

## HOW ULTRAFILTRATION WORKS

Ultrafiltration (UF) is a membrane separation process that allows for removal of suspended solids including particles, colloids, cysts, bacteria, and viruses. UF membranes remove suspended solids based on pore size. The pore size filtered by UF membranes varies widely depending on the material, manufacturing process, and the intended use/application of the specific membrane. (See chart below).

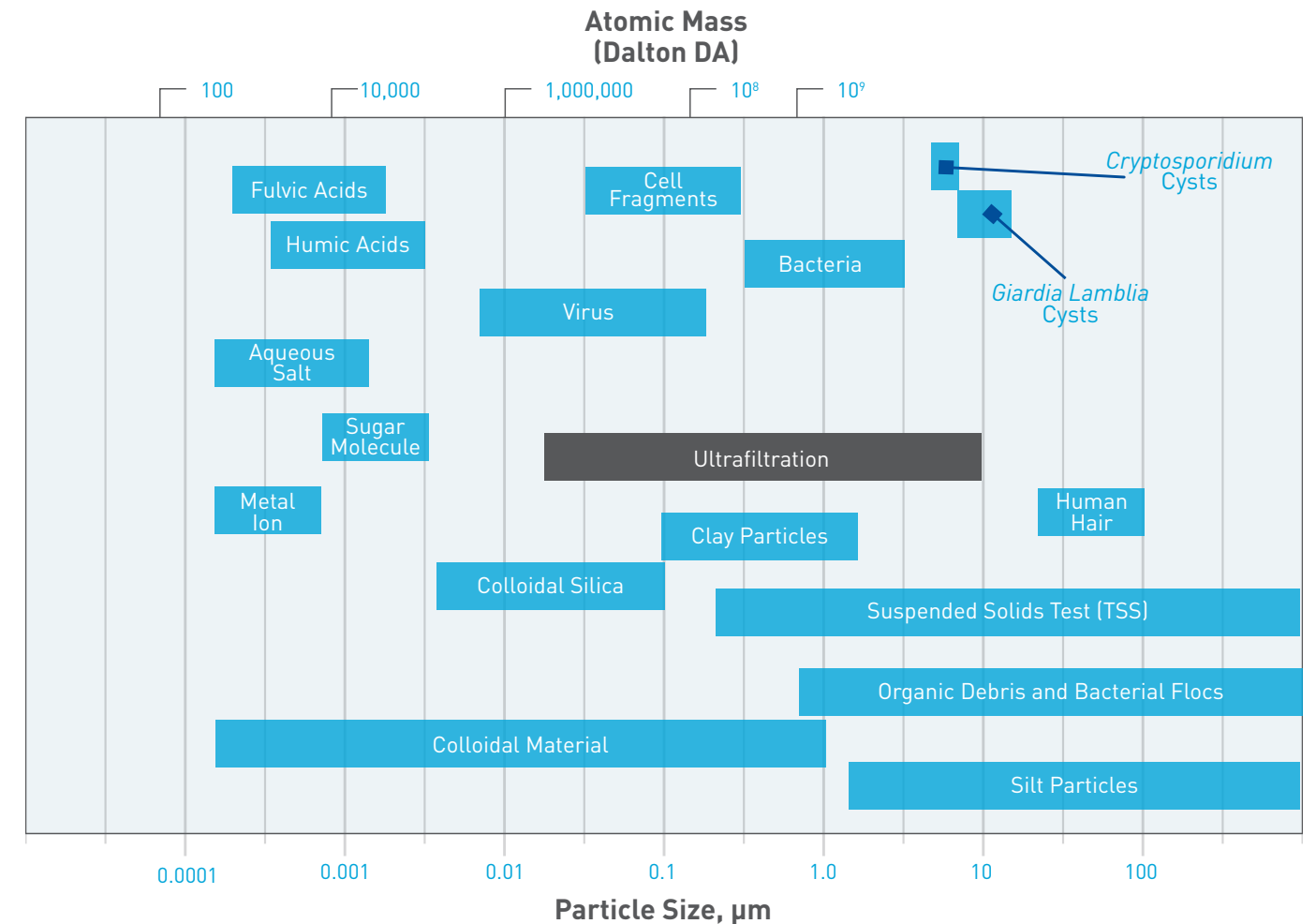

### Membrane Construction

Ultrafiltration membranes are available in a number of configurations including:

**Flat sheet** – Membranes formed in flat sheets, and configured either in plate-and-frame membrane stacks or spiral wound cartridges. Typically used for water supplies that do not have a high potential for fouling and configured for cross-flow filtration with a continuous recirculation/waste flow.

**Hollow fiber** – Membranes formed into hollow fibers and configured in modules containing multiple fibers. Typically operated in a dead end mode (i.e. no continuous waste flow). Flow can be either from the fiber bore to the exterior (inside out) or from the fiber exterior to the bore (outside in).

**Multi-bore hollow fiber** – Similar to hollow fiber membranes except that the fibers are larger and each fiber contains multiple bores (typically four to seven bores).

**Tubular** – Membranes similar to hollow fiber but with tubes that are much larger (0.5" to 1" ID). Typically used for waste water applications and configured for cross-flow filtration with a continuous recirculation/waste flow.

NOTE: This guide covers only hollow fiber and multi-bore hollow fiber membranes. These two types of fiber membranes are preferred due to their robust design and the ability to be cleaned "on line" by periodic flushing.

## HOW ULTRAFILTRATION WORKS

### Filtration Operation

Ultrafiltration systems may be configured to operate in one of three basic filtration modes:

- Cross-flow – A portion of the feed water is continuously recirculated and/or flows to waste to prevent retained solids from building up on the membrane surface.
- Dead end – There is no waste flow from the system. When the filter becomes plugged it is cleaned or replaced.
- Dead end with periodic flushing – There is no continuous waste flow. The membrane is periodically flushed to remove retained solids from the membrane surface.

NOTE: This guide focuses on systems configured for dead end filtration with periodic flushing only.

### Flow Direction

Hollow fiber membranes can be constructed to allow inside out or outside in flow in a dead end mode.

**Inside out flow:** Feed water travels down the bore of the fiber and passes through the fiber to the outside where it is collected as treated (filtrate) water.

**Outside in flow:** Feed water is on the outside of the fiber and passes through to the inside of the fiber where it is collected as treated (filtrate) water.

The preferred membrane configuration (inside out or outside in) is dependent upon the construction method and intended use. Outside in membranes are preferred for waters with very high suspended solids and are primarily applied in waste water applications such as membrane bioreactors used for sewage treatment. Inside out membranes are more efficient and require lower volumes of water for flushing, so they are preferred for applications with lower levels of suspended solids such as prefiltered well or surface water.

NOTE: This guide focuses on inside out UF membrane configurations only.

The figure below depicts an individual ultrafiltration hollow fiber membrane flowing inside out. Water and particulates enter the center of the hollow fiber. Water passes through the membrane wall where it is collected as filtrate, while particles larger than the membrane pores are retained by the membrane. These particles are retained inside the fiber bore until a flush cycle is activated.

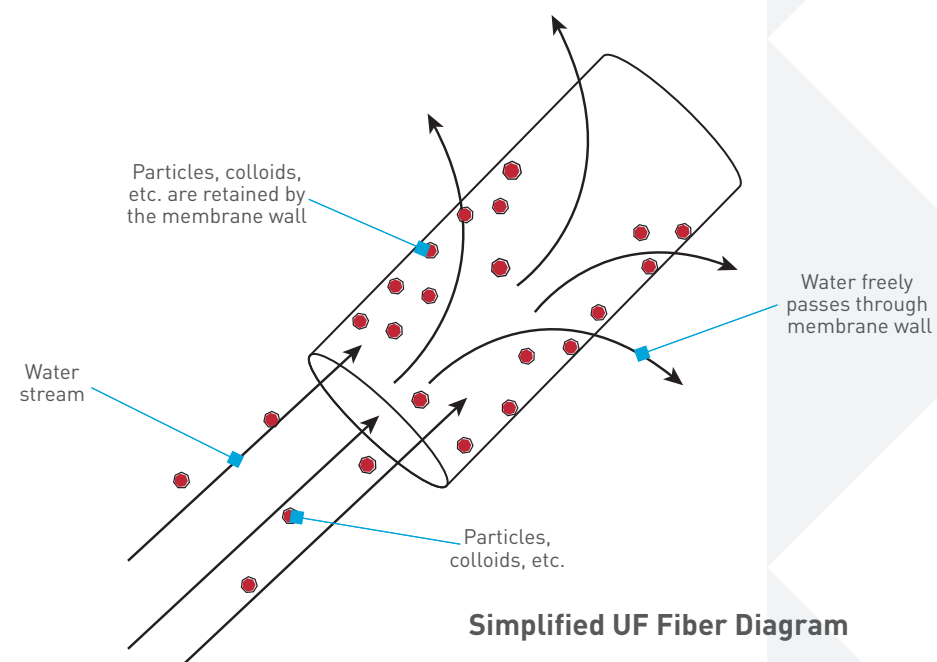

## ULTRAFILTRATION APPLICATIONS

Ultrafiltration (UF) is used for many applications requiring the removal of suspended solids including particles, colloids, cysts, bacteria and viruses. Typical applications include:

### Surface Water Treatment

UF is used as part of a multi-barrier surface water treatment for the reduction of:

- Turbidity
- Fine silt not easily filtered by conventional media filters
- Total Oxidizable Carbon (TOC) associated with high molecular weight organics
- Cysts not easily filtered by conventional media filters or inactivated by chlorine

### Well Water Under the Influence of Surface Water

UF can be used to treat shallow wells for reduction of:

- Turbidity
- Fine silt not easily filtered by conventional media filters
- Total Oxidizable Carbon (TOC) associated with high molecular weight organics
- Cysts that are not easily filtered by conventional media filters or inactivated by chlorine

### Pretreatment of Reverse Osmosis (RO) Feed Water

Pretreating RO feed water with UF increases membrane life and lowers operating costs:

- Lowers feed water Silt Density Index (SDI) – by removing turbidity and colloids
- Removes suspended solids that “break through” conventional pressure filters
- Increases cartridge filter life
- Reduces biofouling by reduction of Total Oxidizable Carbon (TOC) and bacteria

### Prefiltration of Water Feeding Sensitive Equipment

UF can be installed prior to one-time-use specialized filters and other sensitive equipment to lower operating costs:

- Food service – prefiltration of taste and odor and cyst filters greatly extends service life
- Laboratory, pharmaceutical, life science – extends the life of disposable membrane filters

### Postfiltering High Purity Water in Special Applications

UF can be installed after an RO/deionized water (DI) system to improve the quality of the ultrapure water and lower operating costs:

- Pharmaceutical, life science – install in the pure water recirculation loop to extend the life of disposable point-of-use filters
- Ultrapure water – install in the pure water recirculation loop to reduce bacteria, TOC; extends the life of disposable point-of-use filters

### Point-of-Entry Filtration for Residential and Commercial Installations

Installed as part of multi-barrier system, UF offers “peace of mind” by providing an additional barrier on potable water supplies against compromises to the water system, reducing:

- Cysts
- Bacteria
- Turbidity
- Viruses

### Industrial and Municipal Waste Water

UF for waste water treatment is beyond the scope of this guide.

CAUTION: Only systems that are third party certified as water purifiers, and meet state and local regulations, can be used to purify unsafe drinking water supplies.

## WATER QUALITY BASICS

### Water Sources

Waters may be categorized by their source – ground water or surface water. This classification defines the basic history of the feed water, and determines the likely type and level of its impurities – and therefore its quality. Even rain water contains some impurities from the atmosphere.

Surface water is drawn from lakes, ponds, streams, and rivers. It generally contains a greater degree of organic material than ground water caused mainly by decaying vegetation. Surface water is also likely to contain substances from industrial discharge, agricultural runoff, and other human activities. High concentrations of microbes such as bacteria, viruses, and cysts are more common in surface water than ground water.

Ground water, which is drawn from wells, comes from rain water that has percolated through the earth and collected in underground aquifers. Water wells vary greatly in depth, but generally deeper wells have less organic material due to the natural filtration of the water percolating through the ground. Ground water may also be discharged to the surface from natural springs. Ground water tends to have higher concentrations of inorganic compounds.

Ground water in shallow and/or disrupted locations may be considered ground water under the influence of surface water, and have substances normally associated with surface water supplies. For example, shallow well water may contain nitrates and/or coliform bacteria from nearby agricultural activity. Shallow well water, like surface water, may be turbid (i.e. hazy in appearance due to particles floating within).

### Seasonal Variations

Surface water tends to change in quality due to seasonal and weather influences. For example, algae blooms in lakes and rivers may occur in late summer. Lakes and reservoirs in areas with substantial temperature variation “turn over” twice a year, which can drastically change the water composition. Snowmelt and spring rain runoff add more suspended solids and impurities to rivers, and their concentration increases during dry periods. Even municipally treated surface water quality will vary with the seasons. As a result, membrane fouling may be more significant in some months versus others.

### Water Impurities

Water may contain a wide range of foreign material. Matter may be dissolved or suspended in water (present as solutes or particles). Solute are atoms, molecules or compounds that completely dissolve in water (i.e. completely hydrated). Examples include inorganic salt ions such as sodium, calcium, chlorides and sulfates, and organic molecules like sugars and tannic acid.

Particulate matter is that material that is not dissolved and remains a discrete particle suspended in water. Examples include clays, sand, dust, and solutes that reach their saturation point and precipitate out of solution.

Dissolved organic matter includes a wide range of material from very small to large molecules. Examples of naturally occurring organics include tannins, lignin, humic and fulvic acids, proteins and the starches and cellulose of plant cell walls. Surface water often contains substantially more organic matter than ground water. Larger organic molecules may be partially removed by UF membranes.

Colloids are charged particles typically made up of a combination of molecules both organic and inorganic. They are held in suspension by electrochemical forces that put them in a category between a true solute and suspended particles. They are generally viewed as very small particles. Colloids in water include silica and iron (in certain forms).

Virtually all particulate matter (including colloids) larger than the membrane pore size will be removed by the UF membrane. Since the suspended materials are trapped by the membrane, they concentrate on the surface of the membrane and have the potential to foul it. Due to the electrical charge associated with colloids, they can be especially problematic with respect to fouling.

Microbes in water include viruses, bacteria, and single-cell protozoa. Viruses are very small and cannot reproduce if suspended in water – they require a host organism. UF removes most viruses, depending on the pore size and type of virus. Bacteria are larger than viruses and many different types may be present in water. Bacteria reproduce in water especially in stagnant water. Most types of bacteria are harmless to humans, but some bacteria types, especially *E. coli* from animal waste, may cause illness. Protozoa include many species including *Giardia Lamblia* and *Cryptosporidium* cysts which are known to cause gastrointestinal illness.

### Water Analysis

An understanding of the feed water source, including prior treatment and analysis of the feed water, is essential to determine the best configuration and operational settings for a UF system. At a minimum, the following tests are recommended:

**Silt Density Index (SDI)** – An SDI test must be run on-site. This test entails running water through a 0.45um filter at a constant pressure and recording the reduction in flow rate by measuring the time it takes to fill a 500mL beaker initially and then after 5, 10 and 15 minutes of continuous flow. This test provides a good indication of the fouling tendency of the water due to suspended solids and colloids.

**Total Oxidizable Carbon (TOC)** – Organic matter typically is measured as Total Oxidizable Carbon (TOC), also called Total Organic Carbon. TOC is a typical measurement for carbonaceous material in water.

**Turbidity** – Turbidity is a measure of haziness or lack of clarity in water, caused by light diffraction. Although not technically the same as suspended particulate matter, particulates usually cause turbidity.

**Total and Dissolved Iron (TDI)** – Total iron measures both dissolved (ferrous or clear water) and oxidized (ferric or precipitated) forms of iron. UF may remove ferric iron which may foul the UF membrane.

Other tests that may be helpful include:

**Dissolved Organic Carbon (DOC)** – A subset of TOC, DOC measures organic matter that will pass through an analytical membrane to remove particulate matter before testing.

**Tannins, Lignin, Humic Acid, and Fulvic Acid** – Often found in surface waters and require specialized tests. All may contribute to color.

**Total Silica** – Measures all silica in the water, including dissolved and colloidal forms.

## FEED WATER QUALITY AND PRETREATMENT REQUIREMENTS

The performance of any membrane system is highly dependent on feed water quality. It influences membrane life, flushing frequency, cleaning frequency, recommended flow rate, and filtrate quality. It is virtually impossible to predict the precise performance of a system due to the wide range of foulants that can be present in water supplies, and because water supplies vary from season to season and even day to day.

However, a pilot study is the most effective way to determine the long-term performance of a membrane system. It is important that the pilot study include the expected extremes in feed water quality if it is to provide meaningful results.

We will consider several “typical” water supplies when offering guidelines for UF systems applications in this guide. The recommended operating conditions, system configuration, suggested pretreatment equipment, and expected performance are all dependent upon initial feed water quality.

### General Feed Water

- Temperature – 34° to 104°F.
- pH – 3 to 10.
- Iron – Dissolved iron will not foul the membrane nor will the membrane remove dissolved iron. Low concentrations of precipitated iron can be removed but may cause fouling at concentrations above 1 mg/L.
- Chlorine – 4.0 mg/l continuous (200.0 mg/l short term).
- Ozone – 0.0 mg/l.
- Turbidity – 5.0 NTU continuous (20.0 NTU intermittent).
- Silicone/Silicone Lubricants – Must not come in contact with membrane in concentrations that cause fouling.
- Organic Solvents/Chlorinated Solvents – Must not come in contact with membrane.
- Polyelectrolytes – Must not come in contact with membrane in concentrations that cause fouling.
- Free Oil and Grease – Must not come in contact with membrane in concentrations that cause fouling.

### Surface Water (Municipally Pretreated)

- Suggested minimum pretreatment:
  - Flocculation, settling/clarification and filtration (by municipality).
  - Disinfection (by municipality).
  - 200-micron prefilter (optional).
- Chlorine – < 4.0 mg/l.
- Turbidity – < 5.0 NTU.
- TOC – < 2.0 mg/l.
- SDI<sub>15</sub> – < 6.67.
- Metals (Fe, Mn, Cu, etc.) – < 1.0 mg/l.

### Surface Water (Private Multi-Barrier System)

- Suggested minimum pretreatment:
  - In-line coagulation and filtration with multimedia filter.
  - Disinfection with chlorine.
  - 200-micron prefilter (optional).
- Chlorine – > 2.0 mg/l, < 4.0 mg/l.
- Turbidity – < 5.0 NTU.
- TOC – < 10.0 mg/l.
- SDI<sub>5</sub> – < 20.0.
- Metals (Fe, Mn, Cu, etc.) – < 1.0 mg/l.

CAUTION: Dosage of coagulant must be controlled to prevent fouling of the UF membranes.

### Well Water (Municipally Treated Deep Well)

- Suggested minimum pretreatment:
  - Iron removal filtration (if iron over 1 mg/l).
  - Disinfection (by municipality).
  - 200-micron prefilter (optional).
- Chlorine – < 4.0 mg/l.
- Turbidity – < 5.0 NTU.
- TOC – < 2.0 mg/l.
- SDI<sub>15</sub> – < 6.67
- Metals (Fe, Mn, Cu, etc.) – < 1 mg/l

### Well Water (Private Deep Well > 100 ft.)

- Suggested minimum pretreatment:
  - Iron removal filtration (if iron over 1 mg/l)
  - Disinfection – optional
  - 200-micron prefilter – optional
- Chlorine – < 4.0 mg/l
- Turbidity – < 5.0 NTU
- TOC – < 2.0 mg/l
- SDI<sub>15</sub> – < 6.67
- Metals (Fe, Mn, Cu, etc.) – < 1 mg/l

NOTE: Wells under the influence of surface water (such as those less than 100 ft. deep) may require treatment similar to surface water.

### Pure Water (UF used to post-treat high purity RO/DI water)

- Suggested minimum pretreatment:
  - RO
  - Mixed bed DI or Continuous DI system
- Chlorine – 0.0 mg/l
- Turbidity – < 0.1 NTU
- TOC – < 1.0 mg/l
- SDI<sub>15</sub> – < 1
- Metals (Fe, Mn, Cu, etc.) – < 0.1 mg/l

NOTE: The feed water limits shown are for water entering the UF membranes (i.e. after any prefiltration, chemical addition, etc).

## FILTERED WATER QUALITY

The quality of filtrate (filtered water) will vary depending upon feed water quality, operating conditions and the condition of the membrane(s). The filtration performance shown below represents typical results. Pilot testing is required to determine site-specific results.

### Typical Filtered Water Quality

- Particle removal – 99% + removal efficiency for particles 1 micron and larger
- Turbidity – < 5 NTU
- Cyst reduction – 99.95%
- Bacteria reduction – 4 to 6 log reduction (as tested with Klebsiella terrigena)
- Virus reduction – 1 to 4 log reduction (as tested with MS2 coliphage)
- SDI<sub>15</sub> – < 2

## SYSTEM SIZING

Ultrafiltration systems have peak flow and continuous flow ratings. The peak flow rating is based both on standard operating conditions and membranes that are in “as new” condition (i.e. not fouled or degraded). The peak flow rating is typically used to size systems for residential applications. Flows in residential applications are intermittent, and there are very few times that homes actually experience high flow rates.

For example, Aquacraft, Inc. Water Engineering and Management prepared a study for WQA in 2001 to identify indoor flow rate demands in 1,188 homes across various regions of the U.S. and Canada. Findings included:

- 70% of all flows were 2.5 gpm or less
- 92% of all flows were 5 gpm or less
- 99% of all flows were 7.5 gpm or less
- 99.9% of all flows were 10 gpm or less

Commercial applications, however, are more likely to experience sustained periods of continuous flow. Systems for commercial applications should be sized based on the continuous flow rating of the membrane.

### Membrane Flux Rates

Membrane manufacturers typically recommend membrane flow rates in terms of specific flux rates (i.e. gallons per day per square foot of membrane surface [gfd]). These recommended flux rates should be used for system sizing guidance. However, flux rates/system flows may need to be adjusted based on local operating conditions and feed water quality. Pilot studies are the best way to determine an appropriate flux rate.

(Continued on next page)

### Membrane Flux Rates (continued)

Recommended flux rates for various feed water sources/quality are shown in the table below. To obtain recommended flow rates, multiply the flux rate times the membrane area. (See membrane data sheets).

| OPERATING CONDITION   | UNITS | FLUX RATE | TURBIDITY (NTU) | SDI    | METALS (mg/l) | TOC (mg/l) |
|-----------------------|-------|-----------|-----------------|--------|---------------|------------|
| Peak/Initial (@ 25°C) | gfd   | 280       | < 0.1           | < 1    | < 0.1         | < 1        |
| Pure Water            | gfd   | 180       | < 0.1           | < 1    | < 0.1         | < 1        |
| Well Water            | gfd   | 85        | < 1             | < 6.67 | < 1           | < 2        |
| Surface Water         | gfd   | 35        | < 20            | < 20   | < 1           | < 10       |

NOTE: Metals include Fe, Mn, Cu, etc.

### Temperature Correction Factor

UF membrane capacity is dependent upon temperature. Membrane flow drops about 2% to 3% for each 1°C (1.8°F) decrease in feed water temperature. This loss in flow can be counteracted by increasing the pressure, provided that maximum trans-membrane pressure is not exceeded.

This table (see right) shows the loss in flow associated with feed water temperatures below standard test conditions 25°C (77°F). This table assumes that trans-membrane pressure is held constant and only water temperature is changed.

| TEMPERATURE |      | CORRECTION FACTOR |
|-------------|------|-------------------|
| °C          | °F   |                   |
| 25          | 77   | 1                 |
| 22.5        | 72.5 | 0.93              |
| 20          | 68   | 0.86              |
| 17.5        | 63.5 | 0.80              |
| 15          | 59   | 0.74              |
| 12.5        | 54.5 | 0.69              |
| 10          | 50   | 0.64              |
| 7.5         | 45.5 | 0.60              |
| 5           | 41   | 0.55              |
| 2.5         | 36.5 | 0.51              |

## OPERATING GUIDELINES

### Feed Water Quality

Refer to the Feed Water section of this guide (pages 7-9). If the UF is installed as part of a multi-barrier system, the water quality should be checked at the inlet to the UF membranes (i.e. after all chemical addition and prefiltration).

### Prefiltration

A 200-micron prefilter/strainer is recommended.

### Membrane Pressure

Follow the guidelines in the membrane data sheet with regard to allowable trans-membrane pressure.

### Scaling/Fouling

Prevent precipitation in the UF system (e.g. Fe, Mn, CaCO<sub>3</sub>).

### Water Hammer

Prevention of water hammer is required to avoid membrane damage.

### Protection from Abrupt Variations in Temperature

Avoid abrupt variations in temperature. The maximum operating temperature is 40°C (104°F). Temperature equalization should be realized slowly.

### Protection from Abrasive Materials

The membrane must be protected from abrasive materials (e.g. machining shavings, construction debris) which can cause irreversible damage to the membrane.

### Silicone or Lubricants Containing Silicone

Lubricants/materials containing silicone can cause irreversible blockage of the membrane and must not contact the membrane surface. Use glycerin as a lubricant for seals, o-rings, etc.

## SYSTEM CONFIGURATIONS

### Automatic Flushing Operation

Systems may be configured to flush in one or a combination of three basic modes. The table below describes the valve sequencing required.

**Forward-flush** – The drain valve is opened so that the flow through the bore of the fibers is significantly increased. Retained solids are flushed from the membrane surface due to the velocity of the water.

**Back-flush** – The drain valve is opened, the feed water is shutoff, and the filtrate is allowed to reverse flow through the membrane. This “lifts” retained solids from the membrane surface, flushing them to drain. The filtrate used for back-flushing can be provided by a storage tank or by other UF membranes that remain in service.

**Combined flush** – Combines both back-flush and forward-flush simultaneously. This normally occurs by opening the drain valve, while the feed water supply remains open and back-flush water is supplied by other membranes or an external source.

### Flush Valve Sequencing

| SYSTEM FLUSH TYPE                  | CYCLE                            | INLET VALVE | DRAIN VALVE | FILTRATE VALVE   | NOTES  |
|------------------------------------|----------------------------------|-------------|-------------|------------------|--|
| Forward-Flush Only                 | Forward-Flush                    | None        | Open        | None             | Filtrate check valve required if storage tank is used  |
| Back-Flush Only                    | Back-Flush                       | Closed      | Open        | None             | Back-flush water provided by storage tank or other membranes (no filtrate check valve)                                   |
| Sequential Back-Then Forward-Flush | Back-Flush                       | Closed      | Open        | Open (if used)   | If back-flush provided by tank and filtrate valve is not used, then backflow prevention during forward-flush is required |
|                                    | Forward-Flush                    | Open        | Open        | Closed (if used) |  |
| Combined Forward- and Back-Flush   | Combined Forward- and Back-Flush | None        | Open        | None             | Back-flush water provided by other membranes   |

The required flush frequency is dependent upon local operating conditions and may require adjustment after installation. Furthermore, feed water quality may vary seasonally or when alternate water supplies are used. Adjustments to flushing frequency may be required to accommodate changes in feed water quality.

### Initial Recommended Flushing Parameters by Water Source and Treatment

| WATER SOURCE                                  | FORWARD-FLUSH   | BACK-FLUSH      | SEQUENTIAL BACK-THEN FORWARD-FLUSH | COMBINED FORWARD- AND BACK-FLUSH | FLUSH FREQUENCY (GALLONS THROUGHOUT) |
|---|-----------------|-----------------|------------------------------------|----------------------------------|--------------------------------------|
| Surface Water Municipally Treated             | Minimum         | Minimum         | Recommended                        | Recommended                      | 100                                  |
| Surface Water Private Multi-Barrier Treatment | Not Recommended | Not Recommended | Recommended                        | Minimum                          | 50                                   |
| Well Municipally Treated                      | Minimum         | Minimum         | Recommended                        | Recommended                      | 200                                  |
| Well Private                                  | Minimum         | Minimum         | Recommended                        | Recommended                      | 100                                  |
| Pure Water                                    | Recommended     | Recommended     | Recommended                        | Recommended                      | 500                                  |

NOTE: The maximum recommended time between flush cycles is 24 hours. Wells that are under the influence of surface water (such as those less than 100 ft deep) may require treatment similar to surface water.

## Storage Tanks

Some systems may utilize a single UF membrane, while others may use multiple membranes to provide the required flow rate and features. Systems may be configured with a filtrate storage tank or configured as a direct feed system with no filtrate storage tank.

On some systems, it may be beneficial to provide a storage tank to maintain water pressure during the flush cycles, to provide water for back-flushing of the UF membrane, and to provide additional water pressure during short periods of high flow demand. The storage tank may also be used in back-flushing systems to store filtrate for the flush cycle.

The filtrate storage tank can be an atmospheric tank or a closed hydropneumatic tank. The advantages of the closed hydropneumatic tank is that the water is not exposed to airborne impurities and no pump is needed to repressurize the water.

**NOTE:** For the purposes of this guide, it is assumed that the storage tank is a closed hydropneumatic tank unless otherwise specified.

The figure below shows a system with a storage tank used for maintaining even water pressure, but not used for flushing.

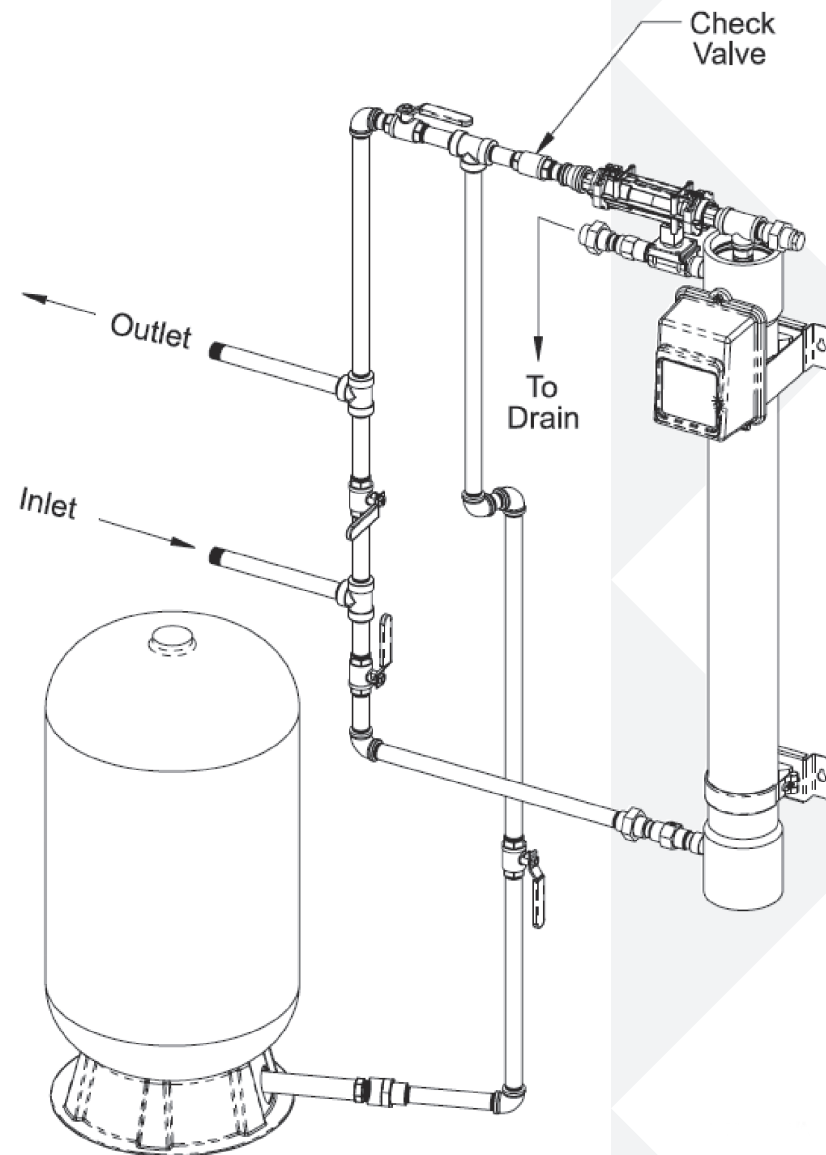

## SHIPPING AND HANDLING

### Careful Transport and Handling

Mechanical damage/rupture of the membrane shell and connections can result if the membranes are dropped or collide. Therefore, membrane units must be handled with care at all times during transportation, installation, and startup.

### Storage

Membranes should be stored in a dry setting with normal ventilation, removed from any direct sunlight, heat or ignition sources. Storage temperature should be between 4° and 30°C (40° and 86°F).

Membrane modules should not be subjected to any freezing conditions.

To prevent dehydration and control bacterial growth, membranes are saturated with a water/glycerin/sodium bisulfite solution (74.75% water, 25% glycerin, 0.25% sodium bisulfite) and sealed in plastic bags or individual membrane housings prior to shipment.

Sealed membranes (in original packaging) can be stored for up to eight months after delivery if stored between a temperature of 4° - 30°C (40° and 86°F).

When exceeding eight months of storage, the indicated solution must be refreshed.

RO or DI water is recommended for the saturation solution. Before storage, membrane modules should be sealed in plastic bags. If processed accordingly, membrane modules can be stored for another two months before the solution would have to be refreshed.

## SYSTEM STARTUP GUIDELINES

### Piping

System and installation piping should be cleaned before the UF system is started so that no impurities, abrasive materials, or oily materials are washed into the membranes. Piping must be purged of air to prevent water hammer which can damage the system.

### Flushing

Flush the membrane to remove the membrane storage solution prior to placing the UF system in service.

### System Disinfection

The system should be disinfected after flushing but prior to use. See this guide's disinfection/sanitizing guidelines (pages 14 - 15).

## MEMBRANE RINSING

To prevent dehydration and biological growth, membranes are shipped and stored in a water/glycerin/sodium bisulfite solution. The following 3-cycle membrane rinse procedure must be performed in order to remove the storage solution prior to use:

### Rinse Cycle 1

- Slowly fill the inflow side of the system with untreated water in order to avoid water hammer.
- Start a Forward-Flush Cycle (direction of flow from the bottom to the top) at a reduced flush flow rate for a minimum of three minutes or longer if required to purge all air from the system (observe the drain flow for air).
- Operate the unit in the normal filtration mode at a low flow rate—provide a range of flow 2.0-2.5 GPM—for a minimum of 20 minutes. Make sure the filtrate outlet is open and all water produced is discharged to the drain.
- If a storage tank is used, make sure that it is drained completely after the first rinse cycle.

### Rinse Cycle 2

- A. Operate the unit in the normal filtration mode at a low flow rate—provide a range of flow 2.0-2.5 GPM—for 20 minutes. Make sure the filtrate outlet is open and all water produced is discharged to the drain.
- B. Initiate a standard flush cycle (which may incorporate back- and forward-flush cycles). Ensure that the system flushes for a minimum of 60 seconds, which may require two flush cycles initiated back-to-back.
- C. If a storage tank is used, make sure it is drained completely after the second rinse cycle.

### Rinse Cycle 3

- A. Operate the unit in the normal filtration mode at a low flow rate—provide a range of flow 2.0-2.5 GPM—for 20 minutes. Make sure the filtrate outlet is open and all water produced is discharged to the drain.
- B. Initiate a standard flush cycle (which may incorporate back- and forward-flush cycles). Ensure the system flushes for a minimum of 60 seconds, which may require two flush cycles initiated back-to-back.
- C. If a storage tank is used, make sure it is drained completely after the third rinse cycle.
- D. Place the system in the normal filtration mode and fill the storage tank, if equipped.

NOTE: This information is provided as a general guideline. Always refer to a specific system's operating and maintenance manual for detailed procedures.

## SYSTEM SANITIZING

The unit should be sanitized/disinfected after the initial startup rinsing procedure or in case of biological fouling.

**CAUTION:** Sodium hypochlorite (bleach) is used for disinfection. The user should acquaint themselves with the appropriate safety precautions for storage and handling of the chemicals being used. Use only sodium hypochlorite. Do not use bleaches containing any other compounds.

Procedure if a cleaning system is available:

1. Prepare a solution containing 100 mg/l (as Cl<sub>2</sub>) of chlorine using UF filtrate water.
2. Remove the inlet, outlet, and drain plumbing from the membrane(s). Connect the cleaning system pump outlet to the membrane feed piping. Connect the drain and filtrate to the cleaning tank.
3. Recirculate the solution for five minutes, returning the filtrate and drain to the cleaning tank.
4. Let the system soak for one hour.
5. Empty the cleaning tank.
6. Refill the cleaning tank with clean water (UF filtrate if available).
7. Pump the water in the tank through the system with both filtrate and drain lines directed to the drain.
8. Reconnect the piping system for normal operation.
9. Operate the unit in the normal filtration mode for ten minutes. Make sure the filtrate outlet is open and all water produced is discharged to the drain.
10. Initiate a standard flush cycle (which may incorporate both back- and forward-flush cycles).
11. If a storage tank is used, make sure it is drained completely after the flush cycle.
12. Operate the unit in the normal filtration mode for ten minutes. Make sure the filtrate outlet is open and all water produced is discharged to the drain.
13. Initiate a standard flush cycle (which may incorporate both back- and forward-flush cycles).
14. If a storage tank is used, make sure it is drained completely after the flush cycle.
15. Place the system in the normal filtration mode and fill the storage tank (if equipped).
16. Sample the filtrate by checking the bacteriological quality. If test results are not satisfactory, repeat the disinfection procedure.

NOTE: Refer to the Cleaning System Schematic in the membrane cleaning section of this guide (page 17).

Procedure if a cleaning system is NOT available:

1. Prepare a solution containing 100 mg/l (as Cl<sub>2</sub>) of chlorine using UF filtrate water.
2. Remove the inlet, outlet, and drain plumbing from the membrane(s).
3. If the system is furnished with a cartridge filter(s) remove the filter elements.
4. Fill the membrane housing(s) and filter sump(s) with the chlorine solution.
5. Let the system soak for one hour.
6. Reconnect the piping system for normal operation. Do not install the filter elements yet.
7. Operate the unit in the normal filtration mode for five minutes. Make sure the filtrate outlet is open and all water produced is discharged to the drain.
8. Stop the unit and reinstall the cartridge filter(s) if applicable.
9. Operate the unit in the normal filtration mode for an additional five minutes. Make sure the filtrate outlet is open and all water produced is discharged to the drain.
10. Initiate a standard flush cycle (which may incorporate both back- and forward-flush cycles).
11. If a storage tank is used, make sure it is drained completely after the flush cycle.
12. Operate the unit in the normal filtration mode for ten minutes. Make sure the filtrate outlet is open and all water produced is discharged to the drain.
13. Initiate a standard flush cycle (which may incorporate both back- and forward-flush cycles).
14. If a storage tank is used, make sure it is drained completely after the flush cycle.
15. Place the system in the normal filtration mode and fill the storage tank (if equipped).
16. Sample the filtrate by checking the bacteriological quality. If the test results are not satisfactory, repeat the disinfection procedure.

Note: This information is provided as a general guideline. Always refer to a specific system's operating and maintenance manual for detailed procedures.

## MEMBRANE INTEGRITY TEST

All membrane elements are factory tested and pass integrity standards prior to shipment. However, a full system integrity test should be conducted upon startup and performed routinely thereafter (once per year minimum). The integrity is used to check for:

- Internal leaks, such as cut or misaligned o-rings
- Damaged membranes

The preferred integrity test is a pressure decay test. This test involves the application of air pressure to the membrane when it is fully "wet-out" (i.e. the pores are full of water, which is the condition of the membrane when it has been properly flushed after startup). The amount of pressure loss is measured over a set period of time. If the pressure declines too fast, this indicates that there is a seal leak in the system or membrane fiber damage.

### General Test Information

- The test requires that the membrane be fully "wet-out" (i.e. all pores full of water).
- The membrane assembly should be drained of all excess water.
- This test does not require the visual detection of a bubble; instead it measures the loss of pressure or vacuum over time via a gauge.
- A certain amount of pressure loss will occur in an intact system from simple diffusion of air through the water trapped in the membrane pores ("baseline decay"). But a higher pressure loss will occur from membrane flaws or broken seals.
- To prevent contamination, use either a clean air source or a 0.2-micron filter on the air source.

### Equipment

- Pressurized air source (~20 psig, 3+ scfm capacity with pressure regulator, typically a small portable air tank or portable compressor).
- Pressure gauge (0-20 or 0-30 psig) with accuracy to 0.1 psi.
- Positive shutoff valve (a bubble-tight ball valve) to isolate the UF membrane inlet, and one to isolate the air source.
- Stopwatch or watch with a second hand.



### Procedure

1. Ensure the membrane is fully “wet-out”; operate the system at its normal flow rate for several minutes by opening the nearest tap downstream.
2. Drain the feed side of the membrane for 10-15 minutes. If possible, drain the filtrate side of the system for 10-15 minutes.
3. Close supply and drain valves to isolate the feed side of the system. The filtrate side of the membrane should be open to atmosphere.
4. Gradually pressurize the feed side of the fibers to 15 psig.

NOTE: Do not over pressurize; this will force the water out of the pores and the membrane will no longer be “wet-out”, resulting in a false failure.

5. Close the valve between the air source and gauge; simultaneously begin measuring time.
6. Note the pressure at 60, 120, and 180 seconds and record it.
7. Relieve air pressure slowly before disconnecting the air lines.
8. If system pressure holds between 14.5 and 15.0 psig after two minutes, the system integrity is good and thus passes the test.
9. If system pressure is 14.5 psig or less after two minutes, check connections and plumbing for possible air leaks.
10. If system pressure drops to less than 14.5 psig after two minutes, the o-ring seal may be pinched, defective, or absent, or the membrane element may be damaged.

NOTE: The flush solenoid may need to be removed and the line capped off to ensure a good air seal.

**Integrity Test Simplified Diagram**

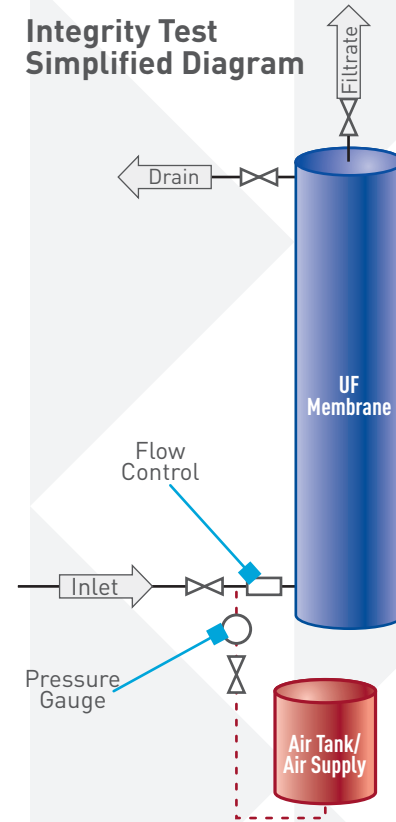

## MEMBRANE CLEANING

Membrane cleaning is required when the surface of the membrane and membrane pores become fouled. This is most often detected by a loss of flow rate. UF membranes should be maintained in a clean condition, unfouled by particulate matter, precipitates, or biological growth.

### Monitoring Membrane Performance for Fouling

Membranes are considered fouled if “normalized” filtrate flow declines more than 10 percent within 24 hours when measured immediately after a flush cycle. Normalizing the filtrate flow is required to account for the differences in feed water temperature and trans-membrane pressure.

### Normalizing Flow Data

Normalize the permeate flow data as follows:

- Operate the system at the same trans-membrane pressure when comparing two data points. Ensure the pressure drop associated with other system components is not included in the data.
- Correct for temperature differences using the temperature correction factor.

Example of a simplified method to normalize flow data:

- Day 1 filtrate flow = 2.5 gpm, water temperature = 20°C (68°F), trans-membrane pressure = 8 psid
- Day 2 filtrate flow = 2.0 gpm, water temperature = 17.5°C (63.5°F), trans-membrane pressure = 7 psid
- Day 2 data normalized to Day 1 conditions:
  - $2.0 \times 8/7$  (pressure)  $\times 0.86/0.80$  (temperature) = 2.46 gpm
  - Therefore, the normalized flux loss is 2%

### Before Cleaning

Before cleaning the membrane(s), make sure the membrane(s) is/are being properly flushed during normal automatic flush cycles. Ensure that there is adequate water pressure during all of the flush cycles and that the design flush flows are achieved. Then implement several manual flush cycles to see if the normalized flow is restored. If flow can be restored by additional flush cycles, it may be beneficial to increase the frequency of the time duration for automatic flush cycles.

### Cleaning Procedure

1. If flushing does not restore membrane flow/flux, clean as follows:
2. Perform two complete, consecutive, automatic flush cycles. Set up cleaning system as shown in the schematic.

NOTE: Cleaning system components must be compatible with the cleaning chemicals.

3. Prepare the cleaning solution per the table at the bottom of this page. Selecting the cleaning solution is dependent upon the type of foulant, which will depend upon feed water source and quality. Some general guidelines:

#### A. Source of water

- If the source water is surface water, the fouling will tend to be organic-based.
- If the source water is ground water, fouling tends to be inorganic-based.

#### B. Inlet water analysis

- If the inlet water has relatively high levels of TOC, DOC, or tannin, focus on organic cleaning methods.
- If the inlet water has relatively high levels of iron, manganese, or hardness, focus on inorganic cleaning methods.

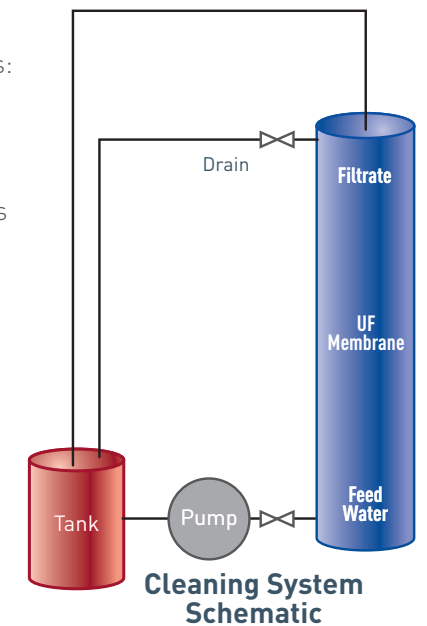

4. Make up the cleaning solution per the table below.
5. Connect cleaning system hoses to the membrane module(s) as shown in the schematic.
6. Start the pump and circulate the cleaning solution through the membrane(s) in the normal flow direction at the normal forward-flush flow rate. Return drain and filtrate hoses to the cleaning tank.
7. Circulate the cleaning solution through the membrane for 15 minutes.
8. Stop the pump and allow the system to soak for 15 minutes.
9. Repeat the recirculate/soak cycles until no additional foulants are being removed.

NOTE: Observe cleaning tank water clarity and dump/replace the cleaning solution if it is evident that the cleaning solution is fouled. Measure the cleaning tank water pH, adding acid if required to maintain the pH between 1 to 3, or caustic if required to maintain pH between 11 and 13.

10. Flush the membranes. (See Membrane Flushing).
11. Disinfect the membranes. (See Disinfection/Sanitizing).
12. Determine the normalized membrane flow/flux.
13. Repeat as needed.

NOTE: This information is provided as a general guideline. Always refer to a specific system’s operating and maintenance manual for the detailed procedure.

1. Use water with 50% NaOH.
2. Use H<sub>2</sub>O<sub>2</sub> 5% solution.
3. Use HCl (30% HCl).
4. Use household or commercial-grade bleach with no fragrances or additives.
5. Use food-grade citric acid.

CAUTION: Cleaning system waste should be treated to comply with local regulations (pH neutralized) before the spent cleaning solution is discharged to drain.

| CLEANING SOLUTION   |                     |                   |
|---|---------------------|-------------------|
| CLEANER   | FOULANT             | FINAL pH OR CONC. |
| Sodium Hydroxide Solution (NaOH)                            | Organics            | 13                |
| Bleach Solution (NaOCl)                                     | Organics/Biological | 200 mg/l          |
| Hydrogen Peroxide Solution (H <sub>2</sub> O <sub>2</sub> ) | Organics/Biological | 500 mg/l          |
| Hydrochloric Acid Solution (HCl)                            | Hardness            | 1                 |
| Citric Acid   | Iron                | 1                 |

## MEMBRANE STORAGE AFTER USE

After initial use, the membrane(s) need to be kept wet at all times. To avoid biological growth during shutdowns or storage, wet membranes should be treated with a compatible biocide.

Downtime up to 24 hours – No measures required

Downtime 1 to 7 days – Automatic flushing

Systems equipped with automatic time-based flush systems (with available feed water) can continue to flush automatically, provided the flush cycle occurs at least every 24 hours for a minimum of 30 seconds.

Downtime 1 to 15 days – Automatic flushing

Systems equipped with automatic time-based flush systems (with available feed water) can continue to flush automatically, provided the flush cycle occurs at least every 24 hours for a minimum of 60 seconds.

Downtime > 7 days – No automatic flushing/membranes stored in place

Membrane(s) should be cleaned and disinfected then filled with a 0.1% sodium bisulfite solution. Leave membrane(s) installed in the system. Replace the sodium bisulfite solution every 15 days.

Downtime > 15 days – No automatic flushing/membrane(s) stored in sealed containers

Membrane(s) should be cleaned and disinfected then filled with a 0.1% sodium bisulfite solution. The membrane should be removed from the system and stored in individually sealed (air tight) containers. Replace the sodium bisulfite solution every 60 days.

In all cases, the membrane(s) must be filled with water when stored.

Any time a storage solution is used, the membrane(s) must be flushed prior to use. See membrane rinsing guidelines (page 13).

## BASICS OF FOULING

As with all filtration media, a UF membrane becomes covered with the material it removes from water. Fouling reduces the filtrate produced at a given trans-membrane pressure and temperature. UF systems are designed to regularly flush to minimize accumulation of the fouling material.

There are four types of fouling, which are understood by their relationship to the membrane structure.

### Cake Layering –

Fouling occurs as the retained material builds into a layer on top of the membrane surface. This “cake” reduces water flow as it grows in thickness and density.

### Pore Blockage –

Occurs when a particle or group of combined particles locate directly over a pore opening on the membrane surface. Like a cork in a bottleneck, this blocks the water from entering the pore and reduces the flow rate in the system.

Cake layering and pore blockage are the easiest types of foulants to remove by flushing. It is also possible for a problematic “sticky” material to develop, causing a type of fouling that may be resistant to removal.

### Interior Pore Fouling –

Material enters the membrane’s pores, then lodges inside the remaining porous structure instead of passing all the way through the membrane. As this trapped material builds up, it reduces the available channel space for water flow, eventually blocking off channels and severely reducing flow.

Interior pore foulants are removed most efficiently by back-flushing rather than forward-flushing.

NOTE: Operating the membrane at high trans-membrane pressure promotes interior pore fouling which may not be reversible.

### Fiber Plugging –

This is an extremely severe fouling condition. In this case, the membrane fiber’s feed channel becomes filled either with large particles or form severe cake layer buildup from membrane fouling. Flow through both the fiber channel and membrane pores becomes severely restricted.

NOTE: Fiber plugging may occur with high concentrations of colloidal materials and iron. If high concentrations of iron or colloidal materials are present, a prefilter system such as a backwashing multimedia filter or iron removal filter should be employed.

## ULTRAFILTRATION TERMS

**Back-Flush (BF)** – Cleaning technique where filtrate is run opposite of normal direction through the membrane, for the purpose of flushing the foulant off the membrane surface.

**Bubble Point Test** – Nondestructive filter test used to determine a membrane element’s integrity and proper installation, based on the pressure necessary to displace a liquid held by surface tension forces from the largest pore in the membrane. The pressure hold test is based on the bubble point pressure.

**Colloid** – Matter which is held in water in a form between a solute and a discrete suspended particle, that does not precipitate but remains as a dispersion.

**Concentrate** – Portion of the feed water that does not pass through the membrane as filtrate, but carries the matter that is retained by the membrane away from the system (also known as reject or drain).

**Cross-Flow Filtration** – Operation mode where the feed stream flows through both the membrane (due to hydraulic pressure) and over the membrane. One influent feed stream becomes two effluent streams (filtrate and concentrate).

**Disinfection** – Process of removing or inactivating organisms in a water supply to a safe level.

**Element** – Membrane configuration that forms a discrete unit which is then placed in a housing for pressurized operation.

**Depth Filtration** – Removal of substances throughout the thickness or depth of the media. Disposable fibrous and wound filter cartridges are examples of depth filters.

**Feed (Feed Water)** – Water source fed to the UF to be purified.

**Filtrate** – Purified water that has passed through the membrane (See Permeate).

**Forward-Flush or Fast Forward-Flush (FFF)** – Cleaning technique where feed flows over the membrane surface at high velocity to drain, instead of through the membrane. The shear force caused by the high velocity removes foulants from the membrane surface.

**Flux** – Rate of filtrate flow through a membrane (usually expressed in volume of per unit time per unit area, such as gallons per day per ft<sup>2</sup> or gfd).

**Fouling** – Accumulation of retained matter on the surface or within the pores of the membrane, resulting in a loss of performance – most noticeably reduced flux.

**Foulant** – Any waterborne material that contributes to membrane fouling.

**Housing** – Pressure-bearing vessel that contains the membrane element during operation.

**Humic Acid** – Various water-soluble organic compounds resulting from decayed vegetable matter.

**Ion** – Charged solute in water, at an atomic or small molecular level (examples: sodium or carbonate).

**Integrity** – Condition of a UF membrane element where no internal bypassing of feed water into the filtrate exists due to broken fibers, membrane tears or failed seals.

**Irreversible Fouling** – When fouling material can not be removed with normal cleaning techniques, including fast forward-flushing, back-flushing or chemical cleaning which can result in a loss of performance.

**Membrane** – Semi-permeable barrier that permits the passage of materials only up to a certain size or electrochemical character.

**Microbes/Micro-Organisms** – Organism that requires a microscope to be seen. In water, these include virus, bacteria, and protozoan.

**Microfiltration (MF)** – Class of membranes that removes particles of a size above the approximate range of 0.05 microns, through sieving (or size exclusion).

**Milligrams per Liter (mg/L)** – Weight to volume ratio of concentration, equivalent to parts per million (ppm).

**Multi-Barrier** – Water treatment system that includes multiple treatment stages.

**Municipal Water** – Drinking water treated by a municipality and of potable quality. Treatment techniques and finished quality are both defined by State and USEPA standards.

**Natural Organic Matter (NOM)** – Any organic matter of natural origin found in water (as opposed to, for example, pesticides).

**Normalization** – Conversion of raw data to reference conditions in order to “standardize” operation to a comparable baseline.

**Operating Pressure** – Hydraulic gauge pressure in the system on the feed stream, or upstream side, of the membrane.

**Parts per Million (ppm)** – Volume to volume ratio of concentration, equivalent to milligrams per liter (mg/l).

**Permeate** – Purified feed stream after passing through a membrane. Also known as “product water” (See Filtrate).

**Pore** – Opening or void in a membrane that determines the size of a solute or particle passing through to the filtrate.

**Reverse Osmosis (RO)** – Separation process where impurities of a size down to the ionic level are removed by a semi-permeable membrane.

**Reversible Fouling** – Fouling material that can be removed with normal cleaning techniques, such as fast forward-flushing, back-flushing or chemical cleaning.

**Sanitization** – Reduction in the number of microbial impurities to safe levels. (See Disinfection).

**Silt Density Index (SDI)** – Value calculated from the rate at which a water source will plug a 0.45-micron membrane. The SDI test procedure is defined in ASTM Standard D4189. The SDI rating provides an indication of rating tendency of the feed water to foul membranes.

**Solutes** – Any matter dissolved in water (as opposed to suspended in water). Often reported as TDS (total dissolved solids).

**Surface Filtration** – Removal of substances mainly at the two dimensional planes of the media surface. Standard polymer membranes are surface filters.

**Suspended Solids** – Particulate matter held in suspension in water (usually particles, but colloids are often considered as suspended because they are not fully dissolved). Often reported as TSS (total suspended solids).

**Total Oxidizable Carbon (TOC) or Total Organic Carbon (based on how it is analyzed)** – Measure of the level of organic matter in water.

**Trans-Membrane Pressure (TMP)** – Hydraulic driving pressure moving water through the membrane, measured as the difference between feed and filtrate (upstream and downstream) sides of the membrane. Also termed “effective pressure”.

**Ultrafiltration (UF)** – Process using hydraulic pressure and a semi-permeable membrane for the separation of components in solutions and suspensions. Membrane pores are of a size that allows passage of water, but will retain non-ionic solutes based primarily on their physical size.

## FREQUENTLY ASKED QUESTIONS

The FAQs below are specific to the Pentair® FreshPoint® Ultrafiltration (UF) system, although they generally apply to most other hollow fiber UF systems as well.

### Q. Is this device designed for use on microbiologically unsafe water?

A. FreshPoint UF is best used as part of a multi-barrier system to treat microbiologically unsafe waters.

CAUTION: Only systems that are 3rd party-certified as water purifiers and meet state and local regulations can be used to purify unsafe drinking water supplies.

### Q. Will UF remove cysts from my water?

A. Yes, cysts will be removed by FreshPoint UF.

### Q. How often does the FreshPoint UF membrane need to be replaced?

A. Membrane life varies widely and is dependent on feed water quality and operating conditions. A 3- to 5-year membrane life is expected for a properly applied, well maintained system.

### Q. What is the nominal pore size?

A. The FreshPoint nominal pore size is 0.02 microns.

### Q. Is the pore size rating absolute?

A. No, the pore size is nominal.

### Q. How do I know the FreshPoint UF System is working?

A. A membrane integrity test should be performed to determine if the membrane is working.

### Q. How do I test the integrity of the membrane?

A. An air test is used to ensure that the FreshPoint membrane integrity is maintained.

### Q. How long does a membrane integrity test take?

A. The integrity test takes about 1/2 hour to complete, but then needs to be followed by sanitizing.

### Q. How much water will the UF system use for flushing?

A. FreshPoint UF uses three to four gallons per flush cycle.

### Q. Can UF be used to remove iron from my water?

A. FreshPoint UF will remove suspended iron particles and colloids above the membrane pore size. However, it is only recommended as a polishing iron filter as high concentrations of iron could plug the fiber bores. FreshPoint will not remove dissolved iron.

### Q. How frequently will the UF system flush?

A. Flushing frequency is programmable. The default setting for FreshPoint UF is 100 gallons or once per day, whichever occurs first.

### Q. Will my water flow be interrupted while the unit flushes?

A. Water will continue to be supplied while the system flushes, but you may notice a reduction in pressure. This reduction in pressure can be minimized by installing a product storage tank.

### Q. Do I have to do anything special with the FreshPoint UF System when I go on vacation?

A. If you are going to leave your water turned on while you are on vacation, the system will continue to flush daily and nothing needs to be done. If you will be gone for an extended period and shutting off the water completely, then preservatives should be added to the membrane.

### Q. What is the maximum flow rate?

A. Maximum flow rate is dependent on operating conditions. FreshPoint Model U440 is rated at a maximum of 10 gpm at standard operating conditions.

### Q. What is the pressure drop at the maximum flow rate?

A. Pressure drop is dependent on operating conditions and feed water temperature. FreshPoint UF has a pressure drop of <15 psid at maximum flow rate/standard operating conditions.

### Q. What is the continuous flow rate?

A. The continuous flow rate is dependent on operating conditions. The FreshPoint U440 is rated at a continuous flow of 3 gpm at standard operating conditions.

### Q. What is the pressure drop at the continuous flow rate?

A. The pressure drop is dependent on operating conditions and feed water temperature. The FreshPoint U440 has a pressure drop of <10 psid at continuous flow rate/standard operating conditions.

### Q. What cleaning chemicals are recommended?

A. Cleaning solutions vary by foulant and include: chlorine, hydrogen peroxide, sodium hydroxide, citric acid and hydrochloric acid.

### Q. Is any prefiltration recommended?

A. The need for prefiltration is dependent upon feed water quality. See the Feed Water Quality section of this guide (pages 7 - 9) for more information.

### Q. What is the permitted operating pH range?

A. A pH range of 3 to 10 is permissible for FreshPoint UF.

### Q. What is the required operating pressure range?

A. FreshPoint® can be operated at inlet pressures up to 120 psig. However, trans-membrane pressure should be limited to prevent long term fouling. See membrane specification sheets for more information.

### Q. What is the permitted operating temperature range?

A. FreshPoint UF can be operated with temperatures from 34° to 104°F (1.1° to 40°C).

### Q. Can I install this unit outside?

A. Outdoor installation is not recommended due to the temperature limits for the FreshPoint UF system.

### Q. What is the drain flow rate?

A. The FreshPoint U440 drain flow is 7 gpm maximum.

### Q. What size and length drain line is permitted?

A. The size of the drain line should be a minimum of 0.75" to meet code requirements. Drain line length should be minimized to prevent water hammer when the flush valve closes.

### Q. Does the module need to be installed vertically?

A. The FreshPoint UF module should be installed vertically for proper venting.

### Q. What is the maximum inlet chlorine concentration allowed?

A. Maximum continuous inlet chlorine concentration for FreshPoint is 4 mg/L.

### Q. What is the maximum inlet turbidity?

A. Maximum recommended inlet turbidity for FreshPoint UF is 5 NTU. Please refer to the Feed Water Quality section of this guide for more information.

### Q. What outlet turbidity can be expected?

A. The FreshPoint outlet turbidity is expected to be <1.0.

### Q. What outlet SDI can I expect?

A. The FreshPoint outlet SDI is expected to be <2.0.

### Q. What system flushing will be required after installation?

A. The FreshPoint membrane(s) must be flushed for approximately one hour prior to initial use.

### Q. Do membranes have a shelf life?

A. Membrane material is stable, however, a maximum membrane shelf life of eight months is recommended (if maintained in its original packaging).

### Q. What flocculants could be used ahead of the membrane(s)?

A. Polyelectrolytes can be used as part of an in-line coagulation / filtration process prior to the FreshPoint UF membrane(s), but great care must be used to avoid overdosing of the polyelectrolyte. Overdosing polyelectrolyte can irreversibly foul UF membranes.

### Q. What lubricants should be used on seals?

A. Glycerin is the preferred lubricant. (Silicone will foul the UF membrane(s).)

### Q. Is a dropped membrane safe to use?

A. Any dropped membrane(s) should be integrity-tested to ensure that it was not damaged.

### Q. What is the preservative solution in a new membrane?

A. Sodium bisulfite and glycerin.

### Q. Do UF systems have to be installed with a flush tank?

A. No, however flush tanks are preferred for most applications to minimize pressure reduction during flush cycles and periods of high flow. They also provide water for back-flushing of the membranes.

## TROUBLESHOOTING GUIDE

This troubleshooting guide focuses on basic membrane/process issues. See a specific system's operating and maintenance manual for troubleshooting information for specific UF systems.

| PROBLEM  | POTENTIAL CAUSE  | CORRECTION   |
|--|--|--|
| Low flow / pressure available.                   | Unit is flushing.  | Wait for flush to be completed.<br>Install a pressure tank to maintain system pressure during flush cycles.                          |
|  | Prefilter(s) is plugged (if so equipped).  | Change prefilter(s) – disposable type.<br>Regenerate back-washable filters.  |
|  | Feed water pressure is too low.  | Increase UF feed water pressure.   |
|  | Membrane is fouled.  | Decrease the volume between flushes.<br>Increase the flush time.<br>Decrease the time between flushes.<br>Chemically clean/sanitize. |
| No product water flow.                           | Bypass valves are not in the correct position.   | Correct bypass valve position to restore flow.   |
|  | Inlet water is shutoff.  | Open inlet valve(s).   |
|  | Prefilter(s) is plugged (if so equipped).  | Change prefilter(s) – disposable type.<br>Regenerate back-washable filters.  |
|  | Membrane is fouled.  | Decrease the volume between flushes.<br>Increase the flush time.<br>Decrease the time between flushes.<br>Chemically clean/sanitize. |
| Unpleasant taste and odor in the water.          | Membranes were not sufficiently flushed following installation, disinfection, or cleaning. | Follow the system startup guide for flushing new membranes.  |
|  | Water has become stagnant from low water use.  | Perform additional flushing of the system per operation manual.  |
|  | Membrane is fouled.  | Decrease the volume between flushes.<br>Increase the flush time.<br>Decrease the time between flushes.<br>Chemically clean/sanitize. |
| Suds in the water.                               | Membranes were not sufficiently flushed following installation, disinfection, or cleaning. | Follow the system startup guide for flushing new membranes.  |
| System not producing the expected water quality. | Impurities are unable to be removed by UF system.  | Refer to UF application guide for approximate removal capabilities.<br>Add additional treatment steps to aid in impurity removal.    |
|  | Seals/internal connections are leaking.  | Confirm with pressure decay test.<br>Replace internal seals.   |
|  | Membrane has an internal leak.   | Confirm with pressure decay test.<br>Replace membrane.   |
| System is flushing continuously.                 | Drain solenoid valve is stuck open.  | Remove debris from the valve.<br>Replace the drain solenoid valve.   |
|  | System controller circuit board is sending continuous flush signal.                        | Confirm the controller is programmed correctly.<br>Contact your Water Specialist for service.  |

## MEMBRANE DATA

### Membrane Data Sheet – FreshPoint® Ultrafiltration System (Model U440)

| UF MEMBRANE SPECIFICATION                               | UNIT OF MEASURE | SPECIFICATION VALUE    |
|---|-----------------|------------------------|
| Membrane Model  | n/a             | Pentair® U440          |
| Membrane Area   | sq. ft.         | 51.0                   |
| Peak Flux Rate  | gfd             | 280.0                  |
| Pure Water Continuous Flux Rate                         | gfd             | 180.0                  |
| Well Water Continuous Flux Rate                         | gfd             | 85.0                   |
| Surface Water Continuous Flux Rate                      | gfd             | 35.0                   |
| Peak Flow Rate (Not Continuous)                         | gpm             | 9.9                    |
| Pure Water Continuous Flow                              | gpm             | 6.4                    |
| Well Water Continuous Flow                              | gpm             | 3.0                    |
| Surface Water Continuous Flow                           | gpm             | 1.2                    |
| Trans-Membrane Pressure – Continuous                    | psid            | 11.5                   |
| Trans-Membrane Pressure – Maximum                       | psid            | 36.0                   |
| Trans-Membrane Pressure – Back-Flush                    | psid            | 36.0                   |
| Molecular Weight Cut-Off                                | Dalton          | 150,000                |
| Operating Temperature – Minimum                         | °F              | 34                     |
| Operating Temperature – Maximum                         | °F              | 104                    |
| Operation   | n/a             | Inside Out             |
| Flush – Fluid   | n/a             | Water                  |
| Flush – Direction                                       | n/a             | Forward and Back       |
| Membrane Type   | n/a             | Multibore Hollow Fiber |
| Capillaries per Fiber                                   | n/a             | 7                      |
| Hollow Fiber ID   | in.             | 0.04                   |
| Hollow Fiber OD   | in.             | 0.17                   |
| Diameter – Nominal                                      | in.             | 4                      |
| Length – Nominal  | in.             | 38                     |
| pH Range – Continuous                                   | pH              | 3 to 10                |
| NaOCl – Continuous                                      | mg/l            | 4                      |
| pH Range – Intermittent (Cleaning)                      | pH              | 1 to 13                |
| NaOCl – Intermittent (Cleaning)                         | mg/l            | 200                    |
| H <sub>2</sub> O <sub>2</sub> – Intermittent (Cleaning) | mg/l            | 500                    |
| NaOH – Intermittent (Cleaning)                          | pH              | 13.0                   |
| HCl – Intermittent (Cleaning)                           | pH              | 1.0                    |
| Citric Acid – Intermittent (Cleaning)                   | pH              | 1.0                    |



**FILTRATION & PROCESS**

5730 NORTH GLEN PARK ROAD, MILWAUKEE, WI 53209

P: 262.238.4400 | F: 262.518.4404 | [WWW.PENTAIRAQUA.COM](http://WWW.PENTAIRAQUA.COM) | CUSTOMER CARE: 800.279.9404

All Pentair trademarks and logos are owned by Pentair, Inc. or its affiliates. All other registered and unregistered trademarks and logos are the property of their respective owners. Because we are continuously improving our products and services, Pentair reserves the right to change specifications without prior notice. Pentair is an equal opportunity employer.

42680 REV B MY13 © 2013 Pentair Residential Filtration, LLC. All Rights Reserved.