

DO NOT DISCARD - GIVE THIS MANUAL TO THE OWNER AFTER INSTALLATION

- Installation must conform to all local plumbing codes and regulations.
- Do **NOT** use with water that is microbiologically unsafe or of unknown quality without adequate disinfection before or after the system.
- Connect system to cold water supply only! Water temperature must not exceed 100°F/38°C.
- Do **NOT** solder plumbing connections attached to the filter housing or inlet valve. High temperature will damage these components.
- Do **NOT** over-tighten fitting connections into inlet valve or housing outlet. Always back-up valves and fittings with a wrench to avoid turning the valve.
- Allow a minimum of 3" under the housing to allow for sump removal and filter replacement.
- Do **NOT** mount the system near a heat source or above the electrical wiring or any device or area that would be adversely affected by water.
- Do **NOT** mount the system behind equipment. The unit must be easily accessible for filter replacement.
- Failure to change cartridges per recommended intervals with OptiPure replacement cartridges may lead to system failure and property damage.

Introduction

Your new OptiPure QT1-Series FoodService Filtration System will cleanse and condition the tap water providing optimum water characteristics for their specified applications. The result is reduced equipment maintenance requirements, longer equipment life and improved quality & consistency of your products. The OptiPure System is built with the finest, most advanced materials and each system is quality inspected and pressure tested prior to shipment. Proper system installation and routine filter changes will ensure years of trouble-free operation and performance.

Please refer to this manual when performing routine filter changes. The instructions make periodic maintenance quick and easy, and ensure you will receive maximum benefit from your system.

System/Operating Specifications & Dimensions

Maximum Pressure: 125 psi/8.6 bar

Maximum Temperature: 100°F/38°C, Min.: 35°F/2°C

Inlet/Outlet Connections: 3/8" fmp

Capacity: Change filters at gallon rating or at least every 6 months, or when pressure gauge needle enters the red zone on the outlet gauge while water is flowing through the filter system under normal operating conditions.

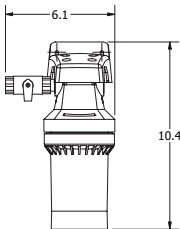

Model QT15-1

Capacity: 6,000 gals./22,712 L

Service Flow Rate: 0.75 gpm/2.85 lpm

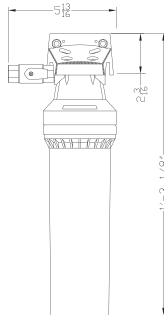

Model QT110-1

Capacity: 15,000 gals./56,700 L

Service Flow Rate: 1.5 gpm/5.67 lpm

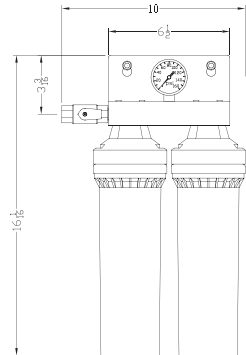

Model QT110-2

Capacity: 30,000 gals./113,400 L

Service Flow Rate: 3.0 gpm/11.34 lpm

Model QTTS10-1

Capacity: 20,000 gals./75,700 L

Service Flow Rate: 2.5 gpm/9.5 lpm

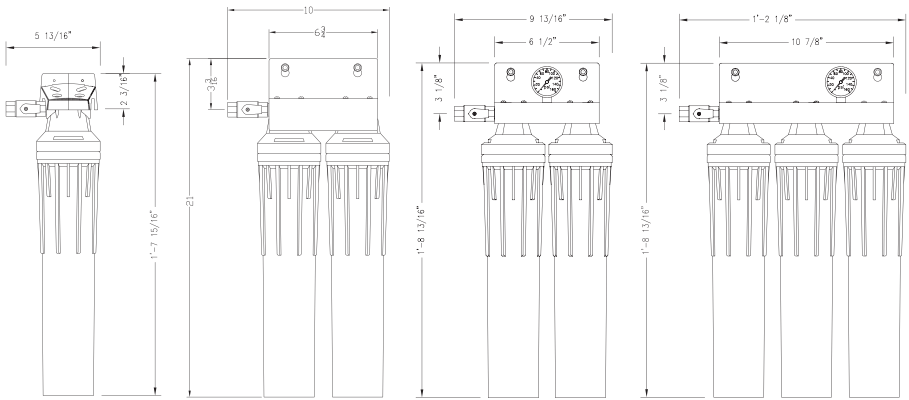

Model QTI-1

Capacity:
22,500 gals./85,162 L
Service Flow Rate:
2.25 gpm/8.5 lpm

Model QTI-1+

Capacity:
22,500 gals./85,162 L
Service Flow Rate:
2.25 gpm/8.5 lpm

Model QTI-2

Capacity:
45,000 gals./170,325 L
Service Flow Rate:
4.5 gpm/17 lpm

Model QTI-2+

Capacity:
45,000 gals./170,325 L
Service Flow Rate:
4.5 gpm/17 lpm

Model QTI-3

Capacity:
67,500 gals./255,487 L
Service Flow Rate:
6.75 gpm/25.5 lpm

Installation Precautions

- Do **NOT** install system on line pressure above 125 psi.
- Do **NOT** install the system backwards with the feed water line connected to the outlet.
- Do **NOT** use liquid pipe compounds for fitting connections. **USE** two to three wraps of Teflon tape.
- Do **NOT** allow system to freeze. Turn off water supply to housing and drain housing if temperature falls below 33°F.
- Do **NOT** install system in direct sunlight or where system is exposed to harsh chemicals or may be subjected to being struck by moving equipment, carts, mops or any other item that may cause damage.
- **IF** water hammer is evident, install water hammer arrestors before OptiPure unit.

Installation Procedure

1. Turn off all equipment to be fed by the OptiPure System.
2. Locate water supply cut-off valve and turn off.
3. Install a minimum 1/2" full-flow ball valve on the water supply side that will feed the water system.
4. Anchor the OptiPure System on a wall stud or suitable mounting material spanning wall studs.
5. Run a suitable line from the full-flow ball valve at the tap water source to the inlet ball valve on the left side of the OptiPure system. Use 2-3 wraps of Teflon tape and brace the inlet ball valve on the system with a wrench when connecting the feed water line.
NOTE: DO NOT OVERTIGHTEN CONNECTION FITTING INTO BALL VALVE.
6. Select the appropriate size tubing for the equipment being fed and connect it to the outlet of the OptiPure System.
NOTE: DO NOT connect the tubing to the equipment at this time. Prior to making connection to the equipment this line will be used to facilitate flushing the system. As an option, a flush valve in a tee on the outlet side of the OptiPure system can be installed in the line to facilitate flushing when changing filters.
7. With OptiPure inlet valve closed, slowly open the full-flow ball valve at the tap water source. Check for leaks.
8. If a flush valve was not installed on the outlet side of the system, hold the tubing that will connect to equipment in a clean bucket or over sink or drain. Open the system inlet feed valve and allow water to flush through system for 10 minutes at the specified system flow rate to allow air and any carbon fines to escape. **NOTE: NO ACTIVATION IS REQUIRED FOR THE OPTIPURE SYSTEM TO PERFORM PROPERLY. FLUSHING IS RECOMMENDED TO ALLOW AIR TO ESCAPE THE SYSTEM AND REMOVE ANY CARBON FINES PRIOR TO CONNECTING TO EQUIPMENT.**
9. Make certain that the end of the tubing to be connected to the equipment is clean and sanitized.
10. Connect tubing to equipment. Open all water supply valves and check for leaks.
11. If no leaks turn on equipment and check for normal operation.
12. Register your warranty.

Operation

With adequate pressure, normal operation of the OptiPure System is completely automatic. Dependable operation involves only monitoring of outlet pressure, periodic filter changes and service documentation.

Pressure Gauge Monitoring

Periodically monitor the pressure gauge on the OptiPure unit. If the needle on the gauge ever enters the red zone (while the connected equipment is in operation and water is flowing through the system to the equipment) it may be an indication that the filters have become clogged with sediment. Ideally the pressure should never drop into the red zone.

Maintenance

The only routine maintenance your OptiPure System should ever require is periodic filter cartridge changes or replacement sump O-rings. Filter changes are necessary for optimum performance of your foodservice equipment. If the system sizing recommendations have been followed the OptiPure System is designed to provide a six (6) month filter replacement interval on most tap water.

Filter Change Frequency

Several situations will mandate filter changes. Complete filter sets should be changed when any of the following apply:

- Six (6) Months have passed since unit installation or previous filter change.
- Reduced water flow.

If filter change frequency is less than 6 months due to pressure drop, it may be necessary to add additional prefiltration or evaluate system sizing recommendations.

Filter Cartridge Replacement Procedure

IMPORTANT: Determine whether all equipment connected to the OptiPure System must be turned off prior to shutting off water supply from filters.

1. Close inlet ball valve.
2. Relieve pressure downline by opening flush valve or briefly actuating equipment.
3. Turn cartridge to the left 1/4 turn until it stops.
4. Pull down on the cartridge until it clears head. Discard old cartridge.
5. Line up the upward-arrow on the new cartridge with the upward pointing arrow on the head.
6. Push cartridge up into head until it stops and turn to right until it stops. (The upward-arrow on the cartridge should align with the downward-arrow on the head).
7. Open the inlet ball valve.
8. Open down-stream flush valve to flush new cartridge at the specified flow rate for a minimum of ten (10) minutes.

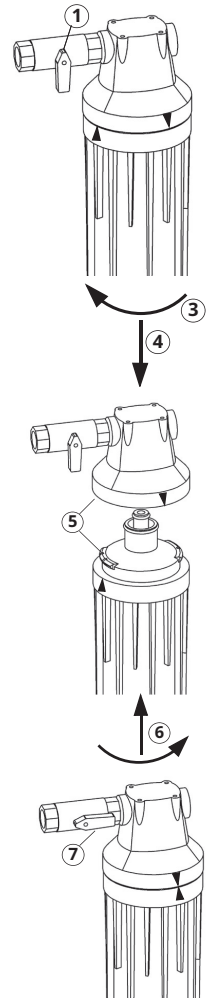

Replacement Parts for: QT15-1, QT110-1, QTTS10-1, QT110-2, QTI-1, QTI-1+, QTI-2, QTI-2+ & QTI-3

Part No.	Description
300-05899	Head, Qwik-Twist - 3/8" I/O
520-12215	Valve, Inlet Ball
530-20019	Pressure Gauge
160-52912	Flush Kit -3/8" (Optional)
160-52904	Gauge Kit for QT10-1, QT-1, QT-1+

Replacement Cartridges

System	Cartridge	Qty.
QT15-1	CTOS-Q5	1
QT110-1	CTOS-Q10	1
QTTS10-1	PTS-Q	1
QT110-2	CTOS-Q10	2
QTI-1	CTOS-Q	1
QTI-1+	S5-Q CTOS-Q	1 1
QTI-2	CTOS-Q	2
QTI-2+	S5-Q CTOS-Q	1 2
QTI-3	CTOS-Q	3

Replacement Filter Cartridges

OptiPure Filter Systems are designed, tested, and certified with OptiPure filter cartridges with proven performance, size and operating capacities. Use of replacement cartridges other than those specified will void warranties, certifications and may compromise equipment protection, water quality and cartridge life.



QTI10-1, QTI10-2, QTI-1, QTI-1+, QTI-2, QTI-2+ & QTI-3
Tested and Certified by NSF International against NSF/
ANSI Standard 42 for the reduction of:

Standard 42: Aesthetic Effects

Chlorine Reduction
Taste and Odor Reduction
Particulate Reduction Class I

NOTE: Testing was performed under standard laboratory conditions, actual performance may vary. It is recommended that you have your water supply tested to determine your actual water treatment requirements.

For further information regarding OptiPure NSF Certified systems visit the NSF website at www.NSF.org.

OptiPure warrants the quality of workmanship of their system components and assembly, except for replacement cartridges and membranes, for a period of 36 months. OptiPure Systems are designed, tested and certified with OptiPure cartridges. Use of replacement cartridges or parts other than those specified will void warranties and Certifications, and compromise equipment protection, water quality and cartridge life.



FilterTrak - Filter System Management Resource

The single biggest problem with filter systems is the lack of attention after the system is installed. Many times the equipment supplied by the filter systems has a service problem related to water because the filter system has not been maintained. This is simply because personnel in the establishment change and it becomes difficult to keep track of what filters are needed and when. FilterTrak eliminates this problem since it automatically notifies users when a scheduled filter change is due and what filter cartridges are needed via mail, fax, email or autoship.

Manufactured by OptiPure

a division of Aquion, Inc.

101 S. Gary Ave, Suite A

Roselle, IL 60172, USA

P: 972.881.9797 | F: 972.422.6262 | email: ps@optipure.net

www.optipurewater.com