

SHURFLO® LVPO F2 LOW VOLUME FILTER STARTER KIT

FILTRATION SYSTEM TO ENSURE CONSISTANT BEVERAGE QUALITY

LVPO F2 Starter Kit: 94-479-00

LVPO F2 Cartridge: 94-470-00



APPLICATIONS

Ice

FEATURES • BENEFITS

Designed for versatile installation capabilities

Fiberdyne® media for right sized capacity and flow rates for lower volume accounts

Optional water boost to ensure consistent flow and pressure

Reduces particulate and protects against scale while maintaining chlorine level for slime prevention

NSF® Certified under NSF Standard 42

INSTALLATION TIPS

Do not use with water that is microbiologically unsafe or of unknown quality without adequate disinfection before or after this system

Filter must be protected against freezing, which can cause cracking of the filter and water leakage

Install this filter on cold water lines only. Do not use on water lines exceeding 100°F (37.2°C). Minimum water pressure of 20 psi (1.4 bar) and a maximum water pressure of 125 psi (8.62 bar) is required

When installing behind an appliance use ample amount of tubing to allow removal of the appliance to prevent damage to the tubing, filter or fittings. Damage to tubing, filter or fittings could cause leakage and damage

OPERATION TIPS

Change cartridge when capacity is reached or at least once a year

Always flush filter at time of installation and cartridge change

SIZING

Service Flow Rate: 3.0. gpm (11.35 Lpm)

Ports: 3/8" NPT

Treatment Capacity: 6,000 gallons (22,712 L)

SHURFLO® LVPO F2 LOW VOLUME FILTER STARTER KIT

94-479-00

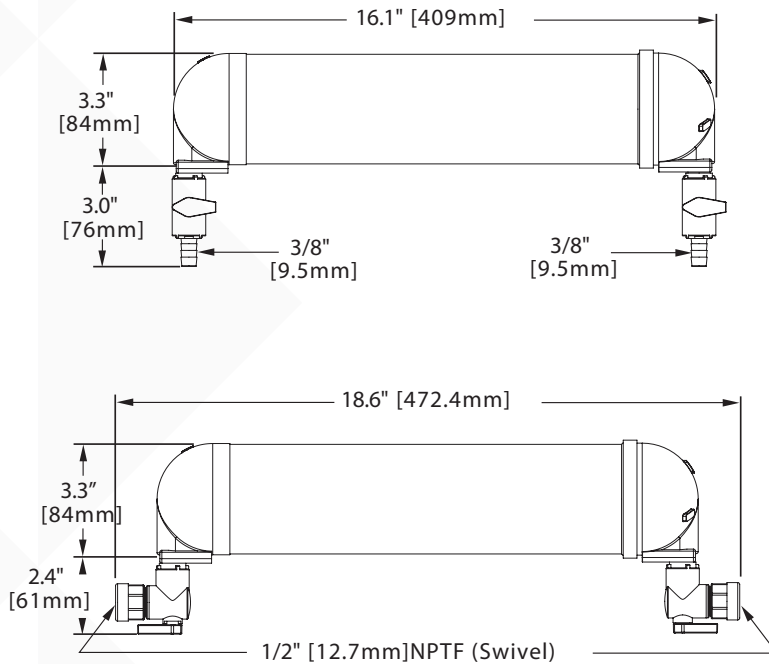

SPECIFICATIONS

Overall Dimensions

18.6" L x 5.7" dia [47.24 x 14.48 cm]

Ports

3/8" NPT

Service Flow Rate

3.0 gpm [11.35 Lpm]

Rated Capacity

6,000 gallons [22.712 L]

Pressure Requirements

20-125 psi [1.4-8.2 bar]

Temperature

40-100°F [4.4-37.8°C]

WARRANTY

Limited Pentair® Warranty is valid from the date of manufacture or with proof of purchase:

2088 - One year
 Water Boost - One year
 Water Pressure Reducer Valve - One year
 8000, 8025, 8010, 8075, 8095 - One year

Pentair will provide a copy of the warranty upon request.



The LVPO-F2 System is Tested and Certified by NSF International against NSF/ANSI Standard 42 for Nominal Particulate Class III.



FILTRATION & PROCESSING SOLUTIONS

EVERPURE-SHURFLO WORLD HEADQUARTERS, 1040 MUIRFIELD DRIVE, HANOVER PARK, IL 60133 USA • WWW.EVERPURE.COM
 800.942.1153 MAIN (US ONLY) • 630.307.3000 MAIN • 630.307.3030 FAX • CSEVERPURE@PENTAIR.COM EMAIL

EVERPURE-SHURFLO AUSTRALIA / NEW ZEALAND, 1-21 MONASH DRIVE, DANDENONG SOUTH, VIC, 3175, AUSTRALIA
 1300.576.190 TEL • AU.EVERPURE@PENTAIR.COM EMAIL

EVERPURE-SHURFLO CHINA, 21F CLOUD 9 PLAZA, NO 1118, SHANGHAI, 200052, CHINA
 86.21.3211.4588 TEL • 86.21.3211.4580 FAX • CHINA.WATER@PENTAIR.COM EMAIL

EVERPURE-SHURFLO INDIA, GREEN BOULEVARD, B-9/A, 7TH FLOOR - TOWER B SECTOR 62, NOIDA - 201301
 91.120.419.9444 TEL • 91.120.419.9400 FAX • INDIACUSTOMER@PENTAIR.COM EMAIL

EVERPURE-SHURFLO EUROPE, PENTAIR WATER BELGIUM BVBA, INDUSTRIEPARK WOLFSTEE, TOEKOMSTLAAN, 30 B-2200 HERENTALS, BELGIUM
 +32.(0).14.283.500 TEL • +32.(0).14.283.505 FAX • SALES@EVERPURE-EUROPE.COM EMAIL

EVERPURE-SHURFLO JAPAN INC., HASHIMOTO MN BLDG. 7F, 3-25-1 HASHIMOTO, MIDORI-KU, SAGAMIHARA-SHI KANAGAWA 252-0143, JAPAN
 81.(0)42.775.3011 TEL • 81.(0)42.775.3015 FAX • INFO@EVERPURE.CO.JP EMAIL

EVERPURE-SHURFLO SOUTHEAST ASIA, 390 HAVELOCK ROAD, #04-01, KING'S CENTRE, SINGAPORE 169662
 65.6795.2213 TEL • FAX: 65.6795.2219 FAX • CSEVERPURE@PENTAIR.COM EMAIL

All Pentair trademarks and logos are owned by Pentair, Inc. All other brand or product names are trademarks or registered marks of their respective owners. Because we are continuously improving our products and services, Pentair reserves the right to change specifications without prior notice. Pentair is an equal opportunity employer.