

3M™ Water Filtration

SPEC# _____

QUANTITY _____

application: **ESPRESSO**

models:

SGP195BN-T



3M™ Water Filtration Products Model SGP195BN-T single cartridge water filtration system helps provide consistent high quality water for espresso and espresso based drinks at flow rates up to 1.0 gpm (3.8 lpm). A high capacity weak acid ion-exchange resin reduces calcium and magnesium ions to help prevent hard scale formation on heating coils and boilers resulting in energy inefficiency, downtime and expensive service calls. Inlet water TDS and alkalinity are also reduced. Inlet water TDS and alkalinity are also reduced. Premium activated carbon reduces chlorine taste and odor and bitterness associated with poor water quality. A built-in bypass direct 75% of the inlet water through the media.

- **SGP195BN-T** has a capacity of 1,200 gallons (4,542 liters) for inlet water with 150 ppm (9 gpg) hardness.

PRODUCT BENEFITS

- Consistent great tasting espresso and espresso drinks from water with reduced hardness, alkalinity, TDS and chlorine taste and odor.
- Increased lifetime and capacity from a built-in bypass that allows 25% of inlet water to pass through untreated.
- NSF and/or FDA CFR-21 compliant materials.
- Reduced hard scale formation on the heating coils by the reduction of calcium and magnesium ions results in improved energy efficiency and reduced downtime and expensive service calls.
- Valve-in-head design simultaneously shuts off and vents water, allowing for simple and virtually trouble-free cartridge change-outs without the need to shut off the upstream feed water.
- Sanitary Quick Change (SQC) encapsulated cartridge design allows for fast and easy cartridge change-outs with a 1/4 turn.
- 3/8" FNPT horizontal inlet and outlet ports allow direct or easily adaptable connections to existing plumbing lines.
- Optional pressure gauge allows monitoring of downstream water pressure.

PRODUCT SPECIFICATIONS

Model Number	Part Number	Reduction Claims	Capacity ¹	Service Flow Rate	Application	Replacement Cartridge
SGP195BN-T	56176-02	Hardness, Chlorine Taste and Odor	1,200 gallons @ 9 gpg (4,542 liters @ 150 ppm)	1.0 gpm (3.8 lpm)	Hard Water	P-195BN: 56150-01

¹Capacity may be approximated by ratio of inlet water hardness



SGP195BN-T

3M™ Water Filtration Products

SPEC# _____
QUANTITY _____
MODEL NUMBER _____
PART NUMBER _____

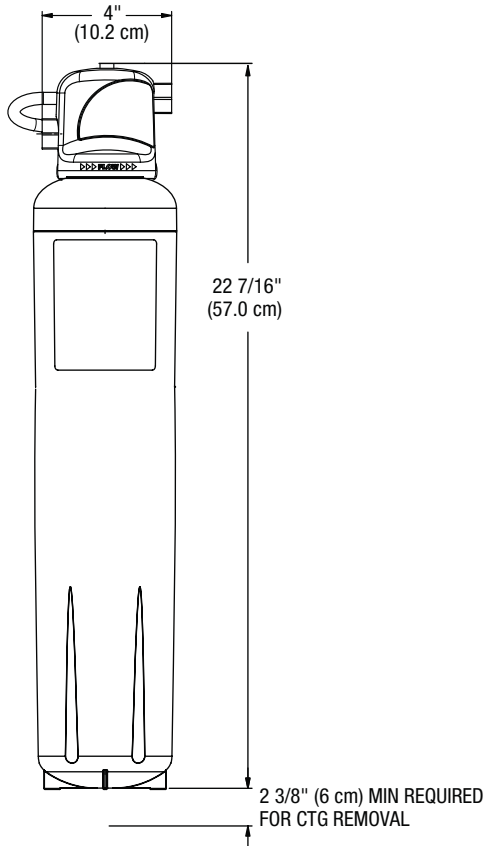

⚠ WARNING: To reduce the risk associated with the ingestion of contaminants:

- Do not use with water that is microbiologically unsafe or of unknown quality without adequate disinfection before or after the system.

CUNO Incorporated recommends regularly scheduled maintenance and replacement of the filter cartridge(s) in order for the product to perform as advertised/sold. CUNO shall not be liable for system failures due to improper maintenance.

LIMITED WARRANTY

CUNO Incorporated warrants this Product (excluding disposable filter cartridge(s)) to be free from defects in material and workmanship for five (5) years from the date of purchase. The disposable filter cartridge is warranted from defects in material and workmanship for a period of one (1) year from the date of purchase. This warranty does not cover failures resulting from abuse, misuse, alteration or damage not caused by CUNO or failure to follow installation and use instructions. If the Product is defective CUNO will replace the Product or refund your Product purchase price. CUNO will not be liable for any indirect, special, incidental, or consequential damages arising from the use of this Product. Some states do not allow the exclusion or limitation of incidental or consequential damages, so the above limitation may not apply to you. To obtain warranty service, mail your request to Warranty Claims, CUNO Incorporated, 400 Research Parkway, Meriden, CT 06450. Proof of purchase (original sales receipt) must accompany the warranty claim, along with a complete description of the Product, model number and alleged defect. This warranty gives you specific legal rights and you may have other rights which vary from state to state, or country to country.

PHYSICAL SPECIFICATIONS

- System includes a head assembly with integral mounting bracket and a single cartridge filter.
- Port for optional downstream pressure gauge in top of head assembly.
- Inlet and outlet plumbing connections are 3/8" FNPT.
- System incorporates an internal automatic 1/4 turn shut-off valve.
- Filter cartridge is o-ring seal type.
- System maximum operating pressure of 125 psi (862 kPa) and operating temperature of 100°F (37.8°C).
- Recommended service flow rate is up to 1.0 gpm (3.8 lpm).
- Filter cartridges incorporate carbon block filtration medium and ion exchange media.
- System materials are NSF and/or FDA CFR-21 compliant.
- Cartridges are sanitary in design, requiring no contact with the filter media during cartridge change-out.
- Filter cartridge requires no pre-activation.
- Shipping weight: 5.8 lbs. (2.6 kg) per case.
- Case quantity: 1.

IMPORTANT: INSTALLATION TIPS

These installation tips are for informational purposes only and are not intended to be used as actual installation instructions. CAUTION: To reduce the risk associated with property damage due to water leakage:

- **Read and follow** Use Instructions before installation and use of this system.
- Installation and use **MUST** comply with all state and local plumbing codes.
- **Protect from freezing**, remove filter cartridge when temperatures are expected to drop below 40°F (4.4°C).
- **Do not install on hot water supply lines.** The maximum operating water temperature of this filter system is 100°F (37.8°C).
- **Do not install** if water pressure exceeds 125 psi (862 kPa). If your water pressure exceeds 80 psi (552 kPa), you must install a pressure limiting valve. Contact a plumbing professional if you are uncertain how to check your water pressure.
- **Do not install** where water hammer conditions may occur. If water hammer conditions exist you must install a water hammer arrester. Contact a plumbing professional if you are uncertain how to check for this condition.
- The disposable filter cartridge **MUST** be replaced every 12 months, at the rated capacity or if a noticeable reduction in flow rate occurs.

