

CONFIGURATION – B
Optional (Horizontal Installation)

For best results, use Configuration – A only

1. Measure the midpoint on the horizontal waste ell and cut out 1 ½” of tubing. (See Fig. 7)

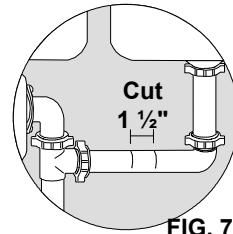

2. Slip S.J. nut and beveled waster over both ends of the cut tube, then insert the 3-way repair tee in the following manner: Loosen the S.J. nut on the horizontal waste ell where it joins the vertical tailpiece. (See Fig. 8) Remove the short “ell” piece by pulling down the tailpiece, then put cut ends of ell into a tee and tilt vertical end back up over tailpiece and re-secure S.J. nut. Rotate tee so that the side outlet is facing straight up, then firmly tighten both S.J. nuts to tee. (See Fig. 9)

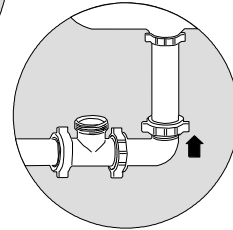
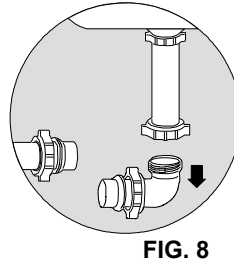

OPTIONAL: To further decrease or eliminate reject water noise, rotate side outlet for a tee from vertical down to 45°

3. Follow instructions 5 & 6 (configuration – A) to complete installation.

**CONFIGURATION – C
(Not Recommended)**

For best results: Do not install an ET112-002 on the horizontal pipe coming straight out of the disposal (See Fig. 10). If the vertical tailpiece is too short, use an ET116-002.

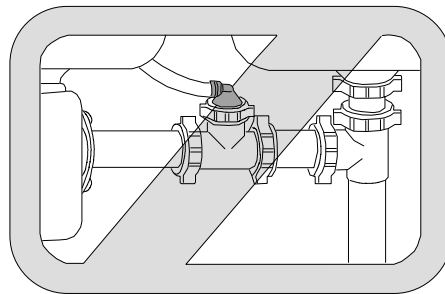

FIG. 10

CAUTION: Be careful not to “over-tighten” any screw on plastic fittings.

NOTE:

To connect reverse osmosis reject water drain line to the plumbing of a single compartment sink with disposal, please request an ET109-002 or ET116-002.

The ET112-002 is designed to be used downstream of an approved air gap.

 MADE IN USA
ASTM F 409

 Serving the
Reverse Osmosis
Water Treatment Industry

Copyright AIR GAP INTERNATIONAL

500 Jefferson Street, Placentia, California 92870 USA • 949-955-3928 • Email: orders@airgap.com

Model:

ET112-002 REVERSE OSMOSIS DRAIN LINE ADAPTER

Pat. No. 5,449,456

Pat. No. 5,681,459

Pat. No. 5,944,985

Pat. No. 6,193,879

MADE IN USA

- ▶ For Multi Compartment
-OR-
Single Compartment Sink
without Disposal



ASTM F 409

 Old Part
Number:
12-38QC
DLA-12™

Doc. # 400-0718-006

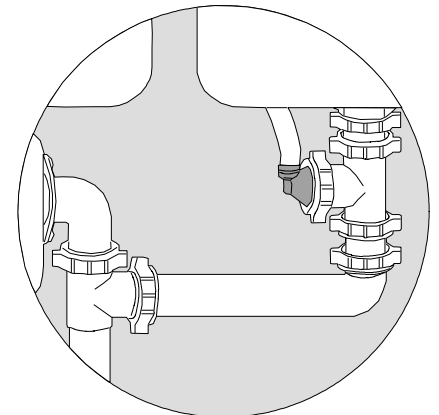





ET112-002

Installation Procedures

For Multi Compartment Sinks or Single
Compartment Sink without Disposal

LIST OF PARTS ENCLOSED

- 1 – Drain Line Adapter with Push-In Connection (ET109-002/ET112-002) 
- 1 – 3-Way Repair Tee 
- 3 – Slip Joint (S.J.) Wing Nuts 
- 3 – Slip Joint (S.J.) Beveled Washers 
- 1 – Locking clip for 3/8" tube 

•The ET112-002 provides an IAPMO / UPC listed alternative to the use of the drain saddle, which is a prohibited fitting in the United States.

• To install the ET112-002 reverse osmosis reject water drain line adapter, follow these instructions.

Please read the instructions once through before starting.

CONFIGURATION – A Recommended (Vertical Installation)

1. Measure the midpoint on the vertical tailpiece between the basket strainer and the horizontal waste extension. A minimum of 4" of uninterrupted tubing is required. (See Fig. 1)

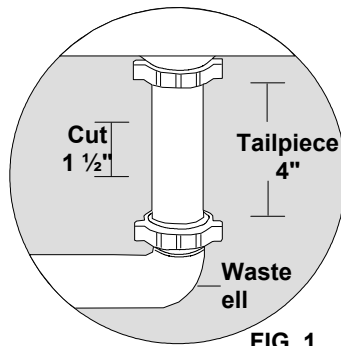

2. Cut out 1-1/2-inch of tubing (3/4-inch on both sides of the midpoint). (See Fig. 1) Always ensure that tube ends are cut squarely and inserted into the bottom of all slip joint sockets.

3. Slip the nut and beveled washer over both ends of the pipe. Always face the beveled side of the washer towards the fitting. (See Fig. 2) Then insert the 3-way repair tee, ensuring that the tube ends seat fully into sockets of the tee. This may be accomplished by loosening the nut joining the horizontal waste ell to the baffle tee until there is enough play to bend the waste ell down, then up into the bottom of the 3-way repair tee. (See Fig. 3)

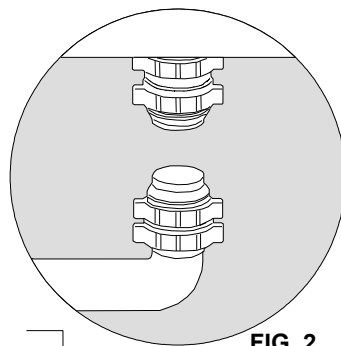

4. Rotate side outlet of repair tee to the desired direction and firmly tighten top, then bottom nuts. Now re-secure the waste ell to baffle tee.

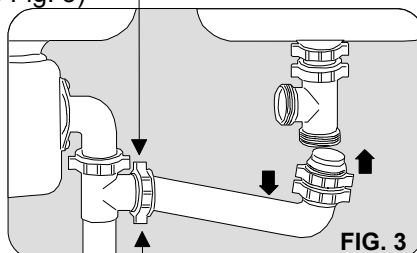

5. Insert new drain line adapter with push-in connector (provided) into side outlet of tee, and rotate towards incoming 3/8" rejected water drain tube. Make sure that adapter is firmly seated in bottom of socket, then tightly secure with beveled S.J. washer and wing nut (provided). (See Fig. 4)

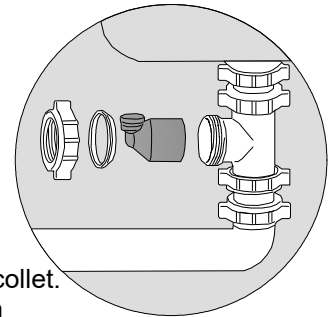

6. Remove locking clip from the collet. Insert 3/8" drain tube into push-in connector to complete the installation. (See Fig. 5)

FIG. 4

7. Apply locking clip for push in connector fittings (See Fig. 5b). Clip fits around the connector to prevent leaks or accidental disconnection of the tube.

NOTE: To install the ET112-002 to a single compartment sink without disposal, follow instructions 1-7 above with the following exception: Once you have removed 1 1/2" of the tubing from the center of the tailpiece (Fig. 1), disconnect and lower the J-bend of the trap. Insert the 3-way repair tee, then reconnect the trap. Use a bowl to catch trap water. (See Fig. 6)

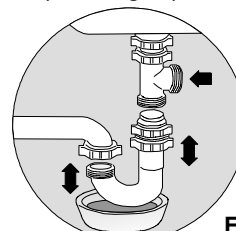

FIG. 6

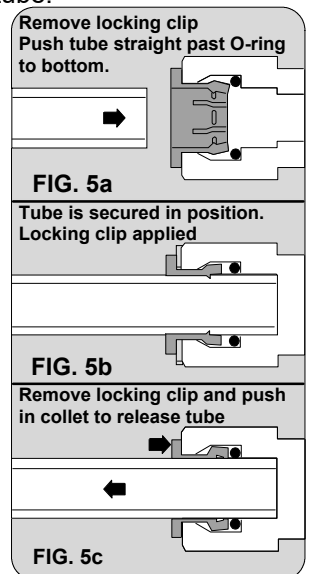

FIG. 5
Quick Connect / Push-In Connector