

# 3M™ Water Filtration Products

SPEC# \_\_\_\_\_

QUANTITY \_\_\_\_\_

application:

**ESPRESSO EQUIPMENT**

model:

## SGP-124B & SGP-248B

The 3M™ Water Filtration Products SGP-124B and SGP-248B Scale-Gard™ Pro System are designed to reduce hard scale build-up on espresso machine boilers, improve beverage quality and maintain efficient brewing machine operations. High capacity ion exchange resin reduces the ability of calcium and magnesium to form hard scale. This exchange also creates an environment in which existing hard scale can actually be dissolved. Premium activated carbon reduces chlorine taste and odor and bitterness associated with poor water quality.

### PRODUCT BENEFITS

- 1/4" NPT horizontal inlet and outlet ports are compatible with common equipment and tubing installation.
- Single or dual cartridge systems allow for specific customization of filtration volume needs.
- Sanitary Quick Change (SQC) encapsulated cartridges reduce contamination during change-outs.
- FDA CFR-21 and/or NSF compliant materials.



**SGP-124B**  
Rated for 422.6 gal.  
(1,600 lit.) @ 180 ppm

**SGP-248B**  
Rated for 845.2 gal.  
(3,200 lit.) @ 180 ppm

### PRODUCT SPECIFICATIONS

Model Number	Part Number	Reduction Claims	Capacity	Flow Rate Each	Application	Replacement Cartridge	Qty	Sizing
SGP-124B	56089-04	Hardness Reduction, Alkalinity Reduction, Chlorine Taste and Odor Reduction	422.6 gal. (1,600 lit.) at 180 ppm	0.5 gpm (1.9 lpm)	Up to 20 Grains	P-124B	1	See chart on back page
SGP-248B	56090-04		845.2 gal. (3,200 lit.) at 180 ppm	1 gpm (3.8 lpm)			2	



# SGP-124B & SGP-248B

# 3M™ Water Filtration Products

SPEC# \_\_\_\_\_  
 QUANTITY \_\_\_\_\_  
 MODEL NUMBER \_\_\_\_\_  
 PART NUMBER \_\_\_\_\_

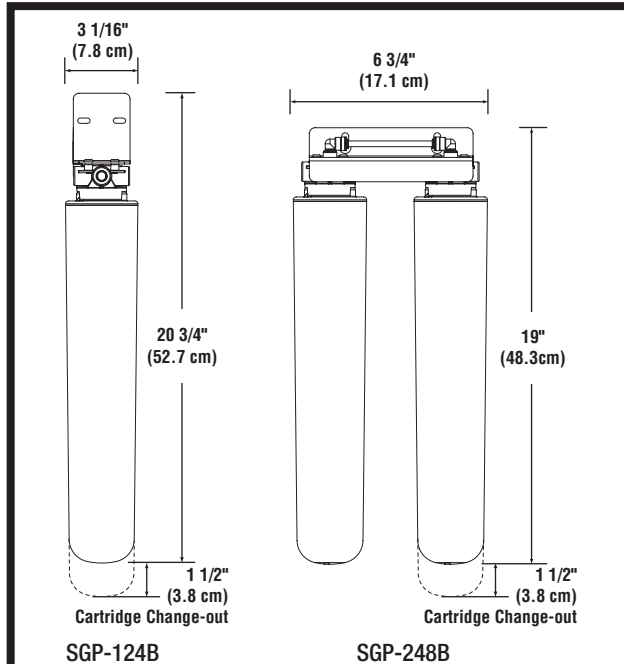

## PHYSICAL SPECIFICATIONS

- System is a single or dual resin cartridge design.
- Dual cartridge system is plumbed in parallel.
- System reduces carbonate hardness through the use of selective ion exchange resin.
- System reduces chlorine taste and odor.
- System reduces alkalinity.
- Resin has no color throw in the effluent water.
- System maximum operating pressure of 125 psi (862 kPa) and operating temperatures of 100°F (37.8°C).
- System materials are FDA CFR-21 and/or NSF compliant.
- Cartridges are sanitary in design, requiring no contact with the filter media during cartridge change-out.
- System flow rate of 0.5 gpm (1.9 lpm).

SGP-124B - Single System				
Incoming Hardness		Gallon Throughput Before Change-out	Number of Cups (Cup size based on 2.2 oz.)	Number of Cups (Cup size based on 8 oz.)
PPM <sup>1</sup>	GPG <sup>2</sup>			
40	2	1,902	110,662	30,432
60	3	1,268	73,775	20,288
100	6	760	44,218	12,160
140	8	543	31,593	8,688
160	9	475	27,636	7,600
180	10	422	24,553	6,752
200	11	380	22,109	6,080
240	13	317	18,444	5,072
280	16	271	15,767	4,336
320	19	237	13,789	3,792
360	20	211	12,276	3,376

<sup>1</sup> PPM - Parts per million  
<sup>2</sup> GPG - Grains per gallon

SGP-248B - Dual System				
Incoming Hardness		Gallon Throughput Before Change-out	Number of Cups (Cup size based on 2.2 oz.)	Number of Cups (Cup size based on 8 oz.)
PPM <sup>1</sup>	GPG <sup>2</sup>			
40	2	3,804	221,324	60,864
60	3	2,536	147,549	40,576
100	6	1,520	88,436	24,320
140	8	1,086	63,185	17,376
160	9	950	55,273	15,200
180	10	844	49,105	13,504
200	11	760	44,218	12,160
240	13	634	36,887	10,144
280	16	542	31,535	8,672
320	19	474	27,578	7,584
360	20	422	24,553	6,752

<sup>1</sup> PPM - Parts per million  
<sup>2</sup> GPG - Grains per gallon

Optional System								
Model Number	Part Number	Reduction Claims	Cap.	Flow Rate	Appl.	Repl. Cartridge	Qty	Sizing
SGP-124BV Valve-In-Head	56098-04	Hardness Reduction, Alkalinity Reduction, Chlorine Taste & Odor Reduction	422.6 gal. (1,600 lit.) at 180 ppm	0.5 gpm (1.9 lpm)	Up to 20 Grain	P-124BV	1	See chart

**⚠ WARNING: To reduce the risk associated with the ingestion of contaminants:**

- Do not use with water that is microbiologically unsafe or of unknown quality without adequate disinfection before or after the system.

CUNO Incorporated recommends regularly scheduled maintenance and replacement of the filter cartridge(s) in order for the product to perform as advertised/sold. CUNO shall not be liable for system failures due to improper maintenance.

## LIMITED WARRANTY

CUNO Incorporated warrants this Product (excluding disposable filter cartridge(s)) to be free from defects in material and workmanship for five (5) years from the date of purchase. The disposable filter cartridge is warranted from defects in material and workmanship for a period of one (1) year from the date of purchase. This warranty does not cover failures resulting from abuse, misuse, alteration or damage not caused by CUNO or failure to follow installation and use instructions. If the Product is defective CUNO will replace the Product or refund your Product purchase price. CUNO will not be liable for any indirect, special, incidental, or consequential damages arising from the use of this Product. Some states do not allow the exclusion or limitation of incidental or consequential damages, so the above limitation may not apply to you. To obtain warranty service, mail your request to Warranty Claims, CUNO Incorporated, 400 Research Parkway, Meriden, CT 06450. Proof of purchase (original sales receipt) must accompany the warranty claim, along with a complete description of the Product, model number and alleged defect. This warranty gives you specific legal rights and you may have other rights which vary from state to state, or country to country.

## IMPORTANT: INSTALLATION TIPS

These installation tips are for informational purposes only and are not intended to be used as actual installation instructions. **CAUTION: To reduce the risk associated with property damage due to water leakage:**

- **Read and follow** Use Instructions before installation and use of this system.
- Installation and use **MUST** comply with all state and local plumbing codes.
- **Protect from freezing**, remove filter cartridge when temperatures are expected to drop below 40°F (4.4°C).
- **Do not install on hot water supply lines.** The maximum operating water temperature of this filter system is 100°F (37.8°C).
- **Do not install** if water pressure exceeds 125 psi (862 kPa). If your water pressure exceeds 80 psi (552 kPa), you must install a pressure limiting valve. Contact a plumbing professional if you are uncertain how to check your water pressure.
- **Do not install** where water hammer conditions may occur. If water hammer conditions exist you must install a water hammer arrester. Contact a plumbing professional if you are uncertain how to check for this condition.
- The disposable filter cartridge **MUST** be replaced every 12 months, at the rated capacity or if a noticeable reduction in flow rate occurs.

