



Limited One Year Warranty

T&S warrants to the original purchaser (other than for purposes of resale) that such product is free from defects in material and workmanship for a period of one (1) year from the date of purchase. During this one-year warranty period, if the product is found to be defective, T&S shall, at its options, repair and/or replace it. To obtain warranty service, products must be returned to...

*T&S Brass and Bronze Works, Inc.
Attn: Warranty Repair Department
2 Saddleback Cove
Travelers Rest, SC 29690*

Shipping, freight, insurance, and other transportation charges of the product to T&S and the return of repaired or replaced product to the purchaser are the responsibility of the purchaser. Repair and/or replacement shall be made within a reasonable time after receipt by T&S of the returned product. This warranty does not cover items which have received secondary finishing or have been altered or modified after purchase, or for defects caused by physical abuse to or misuse of the product, or shipment of the products.

Any express warranty not provided herein, and any remedy for Breach of Contract which might arise, is hereby excluded and disclaimed. Any implied warranties of merchantability or fitness for a particular purpose are limited to one year in duration. Under no circumstances shall T&S be liable for loss of use or any special consequential costs, expenses or damages.

Some states do not allow limitations on how long and implied warranty lasts or the exclusion or limitation of incidental or consequential damages, so the above limitations or exclusions may not apply to you. Specific rights under this warranty and other rights vary from state to state.

P/N: 098-006105-45 Rev.1
Date: 980324
Drawn: CVW
Checked: JLT 4-14-98
Approved: MW 4-14-98

Installation and Maintenance Instructions



KETTLE & POT FILLER B-0600 Series (Also for B-0601, B-0605, B-0606, B-0610 and B-0611)

Deutsch: Installations- und
Wartungsanleitungen

Español: la Instalación y las
Instrucciones de
Mantenimiento

Français: les Instructions
d'Installation et
d'Entretien

Exploded View

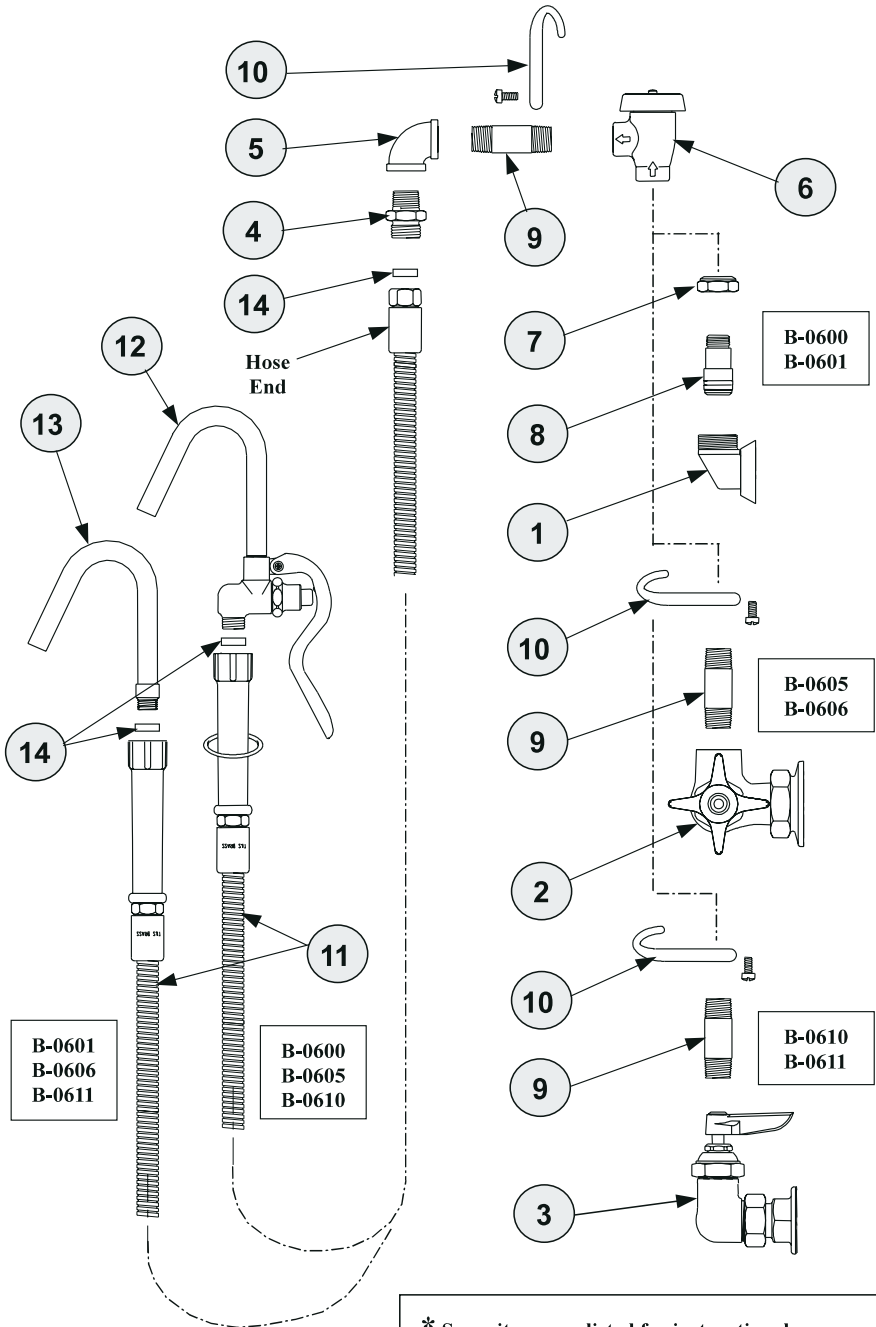

* Some items are listed for instructional purposes and may not be sold as separate parts.

Part Number Guide

Vacuum Breaker & Faucet Assemblies

1	Asm, Body Faucet B-0600 & B-0601	000101-40 & 000181-40
2	Asm, Body Faucet B-0605 & B-0606	B-0310-LN
3	Asm, Body Faucet B-0610 & B-0611	B-0330-LN
4	Adapter 3/8 MA x 3/4-14 MA	000545-25
5	Elbow, 3/8	001355-40
6	Asm, 3/8 Vacuum Breaker	*
7	Nut, Swivel Adapter	*
8	Adapter, Swivel	000843-25
9	Nipple, 3/8 x 2"	000357-40
10	Asm, Finger Hook w/ Screw	002873-40

Spray Valve Assembly

11	Asm, "B68H" Flex S/S Hose	B-0068-H
14	Washer, #27	010476-45
12	Asm, Spray Vlv & Hook	002851-40
13	Asm, Hook Nozzle 33-A	002860-40

General Instructions

Installation: B-0600

Other units will be similar, except where noted.

1. Shut off water supply and drain lines. Existing supply lines should be roughed into wall or sink decking. Use ½" NPT inlets.
2. Install no.1 to supply line, using teflon tape. Flange of no.1 should screw in toward body. Once no.1 is in place, adjust flange against wall or sink deck.

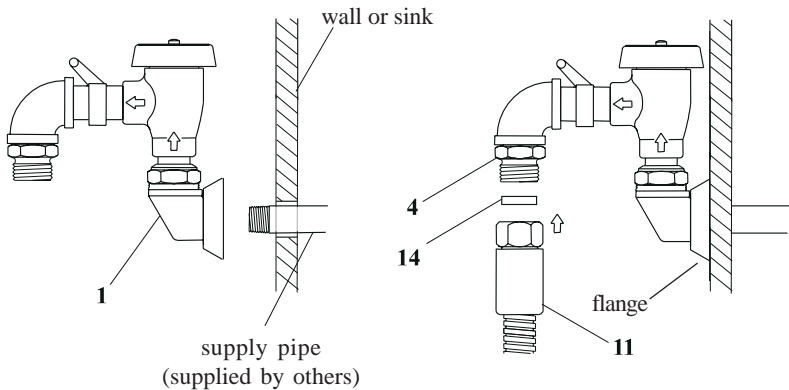

3. Attach no.11 to no.4 (with no.14 in place). Attach other end of no.11 to no.12 or no.13 (with no.14 and hold down ring in place, where used.)
4. Turn on water supply and check for leaks.

Note: Installation of B-0610 and B-0611 requires (2) two supply lines (Hot and Cold) roughed into wall or sink deck, 8" center to center. Use teflon tape on threads.

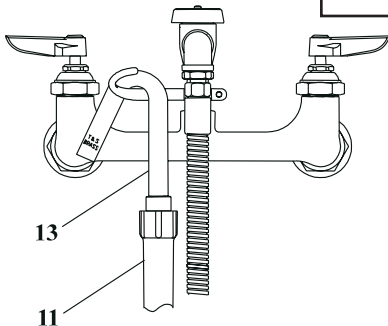

Note: B-0601, B-0606 and B-0611 do not have squeeze valves at end of hose. No.13 is attached directly into end of no.11.

Instrucciones Generales

Instalación: B-0600

Otras unidades serán similares, excepto donde está indicado

1. Cierre la fuente principal de agua y deságüe las tuberías. Las líneas existentes de surtido, deben de ser aproximadas en la pared ó en el armario de la sentina, use entradas de 1/2" NPT (rosca de tubo).

2. Instale la parte No.1 a la línea del surtido, usando cinta para rosca de tubo. El reborde de la parte No.1 debe ser atornillado en la dirección del tronco. Una vez que la parte No.1 esté en su lugar, ajuste el reborde contra la pared ó el armario de la sentina.

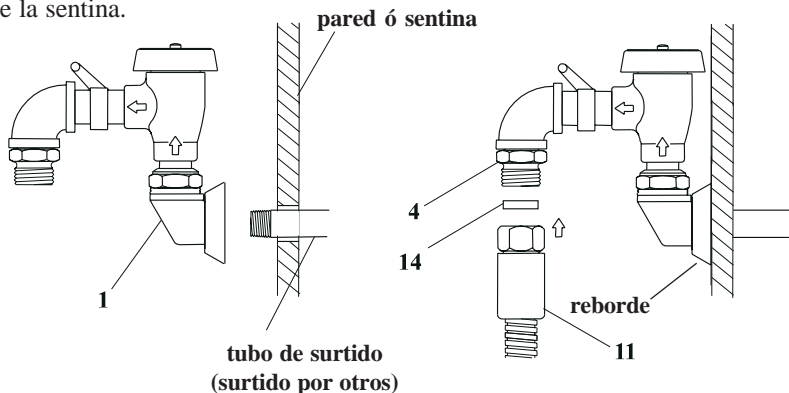

3. Junte la parte No.11 a la parte No.4 (con la parte No.14 en su lugar). Junte el otro extremo de la parte No.11 a la parte No.12 ó No.13 (Con la parte No.14 y la argolla retenedora en su lugar, donde sea usada).

4. Abra la fuente de agua e inspeccione por filtraciones.

Nota: Instalación de B-0610 y B-0611 requiere (2) dos líneas de surtido (Caliente y Fría) aproximadas en la pared ó el armario de sentido, 20.3 cm centro a centro. Use cinta para rosca de tubo.

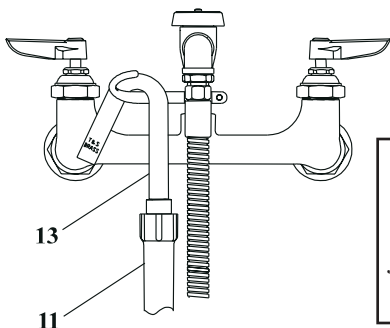

Nota: B-0601, B-0606 y B-0611 no tienen valvulas comprimibles al extremo de la manguera. La parte No.13 esta juntada directamente dentro del extremo de la parte No.11.

Instructions Générales

L'Installation: B-0600

Les autres éléments aller être semblable, sauf où noter.

1. Fermer la réserve de l'eau et égoutter la tuyauterie. La tuyauterie qui fournir l'eau qui exister devoir être installer dans le mur ou le comptoir de l'évier. Utiliser les inlets 1" NPT.
2. Installer N°.1 au tuyau qui fournir l'eau, en utilisant le ruban en Téflon. La bride de N°.1 devoir visser vers N°.1 soi-même. Quand N°.1 être à sa place, régler la bride contre le mur ou le comptoir de l'évier.

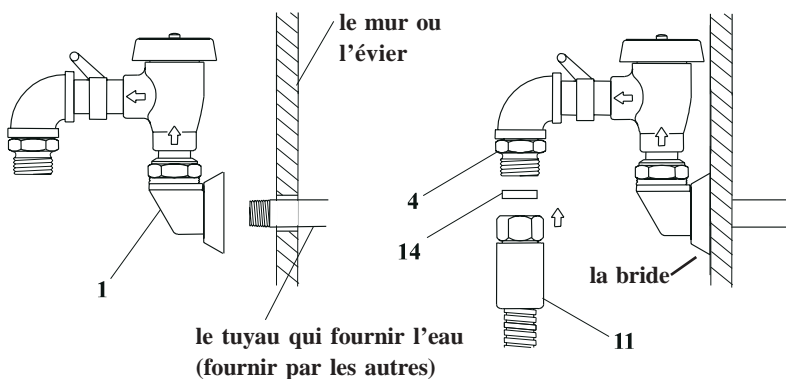

3. Attacher N° .11 à N° .4 (avec N° .14 à sa place). Attacher l'autre extrémité de N° .11 à N° .12 ou N° .13 (avec N° .14 pour retenir l'anneau à sa place, où on l'utiliser).
4. Recommencer l'eau et vérifier s'il y a des fuites.

Noter: L'installation de B-0610 et B-0611 nécessiter (2) deux tuyaux qui fournir l'eau (Chaud et Froid) installer dans le mur ou le comptoir de l'évier, 20.3 cm centre à centre. Utiliser le ruban en Téflon sur les filets.

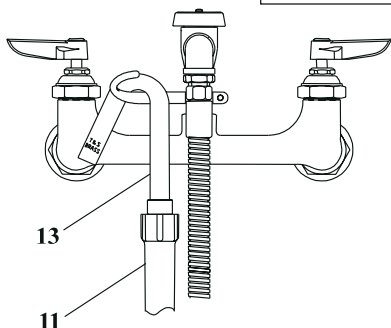

Noter: B-0601, B-0606 et B-0611 n'avoir pas les soupapes de pression à l'extrémité du tuyau N° .13 attacher directement dans l'extrémité de N° .11.

Allgemeine Anleitungen

Installation: B-0600

Die anderen Einheiten sind ähnlich, sofern nichts anderes angegeben

1. Wasserzufuhr sperren und Wasserleitungen entleeren. Bestehende Wasserleitungen sind in die Wand oder die Abdeckplatte für das Waschbecken einzuführen. 1,27 cm NPT-Einlaßventile verwenden. (NPT = Nation Pipe Taper)
2. Teil Nr.1 unter Verwendung von Teflonband mit der Wasserleitung verbinden. Flansch von Nr.1 in Richtung Vorrichtung einschrauben. Wenn Nr.1 eingeschraubt ist, Flansch gegen Wand oder Abdeckfläche des Waschbeckens justieren.

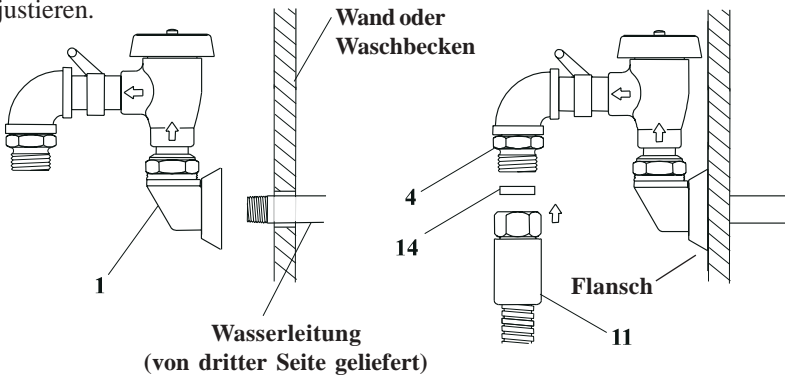

3. Teil 11 mit Nr.4 verbinden (dabei ist Teil 14 richtig ausgerichtet). Das andere Ende von 11 mit 12 oder 13 verbinden (mit Teil 14, falls verwendet, und den Ring richtig nach unten ausgerichtet festhalten).
4. Wasserzufuhr öffnen und auf Lecks überprüfen.

Anmerkung: Installation von B-0600 und B-0611 erfordert zwei (2) Wasserleitungen (warm und kalt), die 20,32 cm von Mitte zu Mitte in die Wand oder Abdeckfläche für das Waschbecken einzuführen sind. Teflonband für das Gewinde verwenden.

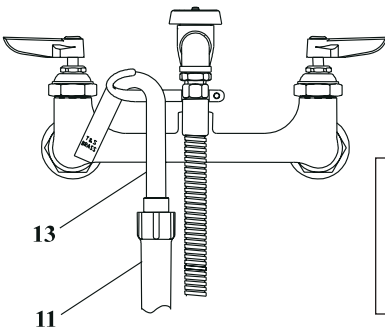

Anmerkung: B-0601, B-0606 und B-0611 haben am Schlauchende keine Druckdüsen. Teil 13 wird direkt an das Ende von Teil 11 angesetzt.

RELATED T&S BRASS PRODUCT LINE



B-0592
Pot and Kettle
Filling Faucet



B-0597
Pot and Kettle
Filling Faucet

T&S BRASS AND BRONZE WORKS, INC.

A firm commitment to application-engineered plumbing products

2 Saddleback Cove, P.O. Box 1088,
Travelers Rest, SC 29690

Phone: (864) 834-4102

Fax: (864) 834-3518

E-mail: tsbrass@tsbrass.com

T & S Brass-Europe

'De Veenhoeve'

Oude Nieuwveenseweg 84

2441 CW Nieuwveen

The Netherlands

