



**The High Efficiency Reverse Osmosis  
Drinking Water System Installation,  
Operation and Service Manual**

---

**PRO-41000-A Series**

---



## Table of Contents

Introduction - Pre Installation Precautions .....	3
Reverse Osmosis System and Component Introduction .....	4
Water Flow and Component Diagram .....	5
Membrane and Flow Restrictor Location and Installation.....	6
Permeate Pump and Outlet Elbow Assembly Installation .....	7
Component Location Diagram .....	8
System Component and Replacements .....	9
Drain Saddle Location Description .....	10
Drain Saddle and Feed Supply Installation .....	11
Airgap Faucet Installation .....	12
Final Tubing Connections .....	13
System Start-up Steps and System Maintenance .....	14
Filter Replacement -Pre/Post and Membrane .....	15
Filter Replacement Remineralization Cartridge .....	16
Tank Sanitizing Instructions .....	17
Troubleshooting Guide .....	18
Warranty Information .....	19
Contact Information .....	20



Scan this code to see a video tutorial on the installation of this reverse osmosis drinking water system

## Typical Reductions:

- Arsenic (As5)
- Barium
- Cadmium
- Chromium (6, 3)
- Copper
- Fluoride
- Lead
- Nitrate
- Radium 226/228
- Selenium
- TDS
- Cysts

Dimensions		
A.	Depth	6.25"
B	Width	14"
C	Height	16.5"



## Pre Installation Precautions

- **Location of the RO system, water supply, and drain** - Using the diagrams on page 8, make sure there is adequate space for the system, the tank, and there is access to the cold water supply and drain
- **Location for the Air Gap Faucet** - Refer to page 10 to make sure you understand the location and installation requirements of an air gap faucet. (Not included with this system)
- **Water Quality** - In order for the system to function properly, it is important to make sure that the feed water is within the parameters shown below in the applications and operating parameters table. Operating the system outside of these parameters will negatively effect the system's performance as well as the longevity. Pretreatment may be necessary to allow the system to work properly.
- **Water Pressure** - The reverse osmosis process requires adequate feed pressure to overcome the natural function of osmosis. The minimum feed pressure should be 40-50 psi. If level of Total Dissolved Solids (TDS) is over 500 in the feed supply a booster pump is highly recommended.
- **Electricity (if Needed for a booster pump)** - If a booster pump is necessary, make sure you have an outlet in the cabinet to plug in to.
- **Pre and Post Filters** - To save shipping space, they have been loaded into the filter housings but are still shrink wrapped. Unscrew the housings, remove the filters and remove the shrink wrap before loading them back into the housings.

Application and Operating Parameters			
<b>Water Pressure</b>	40-100 psig (280-690 kPa)	<b>Water Supply</b>	Chlorinated, Chloramines, Non Chlorinated
<b>Temperature</b>	40-100°F (4-38°C)	<b>Turbidity</b>	<1 NTU
<b>pH</b>	4-11 (Optimal at 7.0-7.5)	<b>Iron</b>	< 0.3 ppm (mg/L)
<b>Maximum TDS</b>	2000 ppm / mg/L	<b>Manganese</b>	< 0.05 ppm (mg/L)
<b>Hardness</b>	Less than 10 gpg (171 mg/L)	<b>Hydrogen Sulfide</b>	< 0.001 ppm (mg/L)

CAUTION: Do not use on water that is microbiologically unsafe or of unknown quality without adequate disinfection before or after the unit. For use on potable water only.

## Reverse Osmosis System and Component Introduction

Your new Reverse Osmosis Drinking Water System (RO) uses a combination of filtration and membrane technologies and efficiency components to provide the highest quality water possible. The following components combine to give you high quality water in the most efficient way possible.

### Pre and Post Filtration

The first stage is a 5 micron activated carbon block, the pre-filter, which is designed to reduce chlorine that may be present to protect the membrane as well as eliminating taste and /or odors. Another 5 micron activated carbon block acts as the post filter in between the storage tank and the faucet to give the RO water a fresh pass through carbon before it goes into your glass.

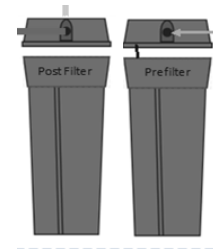

### Reverse Osmosis Membrane

The RO Membrane is the heart of the filtration system. It is designed to reduce the dissolved mineral content of the water. Minerals picked up in the environment by the water are measured as Total Dissolved Solids (TDS). In the Reverse Osmosis process, dissolved minerals are separated from the incoming water (Feed Water) to produce the product water (the Permeate). The excess minerals are rinsed to drain (brine water).



The membrane is a specially constructed, fully aromatic polyamide film and is classified as a Thin Film Composite (TFC). The spiral wound construction of the RO Membrane provides maximum surface area for water production and is less susceptible to fouling by particulate matter, turbidity and colloidal materials.

### Permeate Pump

This component provides the system efficiency that most RO systems do not possess. Powered only by the hydraulic energy of the reject water usually lost to the drain (i.e. no electricity required), the Permeate Pump forces product water into the storage tank, reducing membrane back pressure and maximizing available feed pressure. These pumps dramatically improve the efficiency of RO water production, **reducing wastewater by up to 80%**. It also enhances water production and water quality from the membrane. That means it will fill the tank faster and the water will be a higher quality!

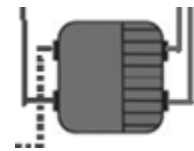

### Automatic Shut-Off Valve

The ASO Valve senses when the Holding Tank is full and closes the feed water supply. This prevents excess reject water from going to drain when the unit is not producing water. This device, used in conjunction with the permeate pump makes this system one of the most efficient available.

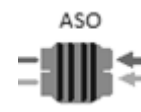

### Remineralization Cartridge

Water directly produced by the membrane travels through the ALKAline re-mineralization cartridge. This increases water alkalinity through exposure to re-mineralization media boosting the water's pH and increases beneficial mineral content.

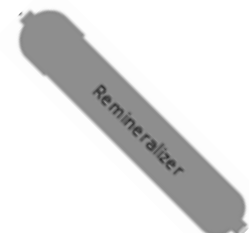

## Water flow and Connections

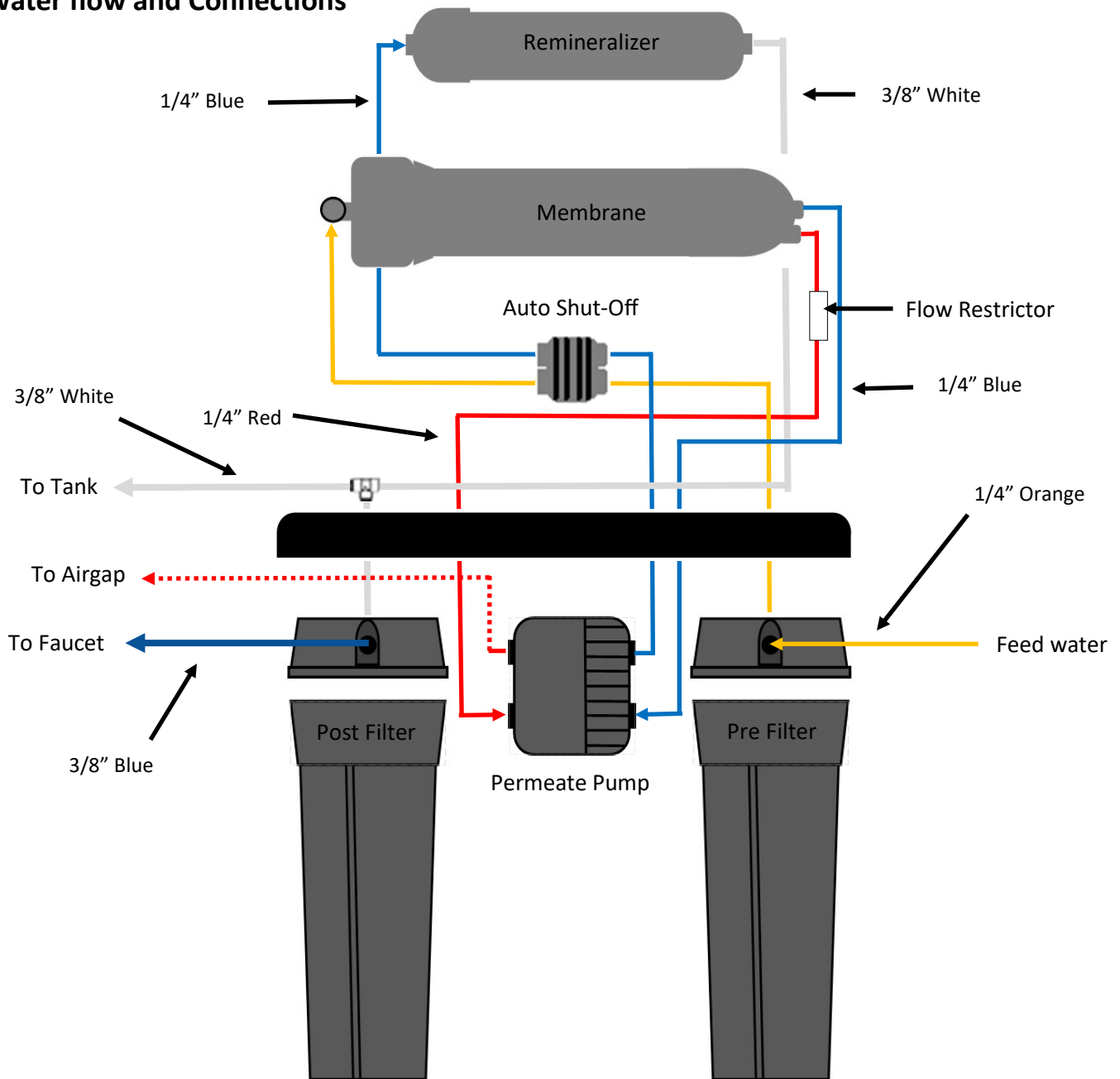

## Installation Kit Components

- Tubing for connection to water supply, tank, faucet and drain
- Feed supply adapter
- Drain saddle clamp
- Stem adapter and elbow fitting for post filter outlet
- Filter housing Wrench



\*Assembled with NSF Certified components

## Install the Membrane and Flow Restrictor

The membrane and flow restrictor are packed in the box and must be installed.

1. Disconnect the feed supply tubing attached to the cap of the membrane housing and then unscrew the cap from the housing.
2. Insert the membrane, o-ring end first with the brine seal on the cap end. Push it in all the way.
3. Replace the housing cap and reconnect the feed supply tubing

Each membrane output size has to have an appropriate flow restrictor for the system to operate properly. If not already in place, the inline flow restrictor installs on the red brine tube coming from the bottom of the membrane housing as shown in the diagram to the right. Make sure the arrow points away from the membrane.

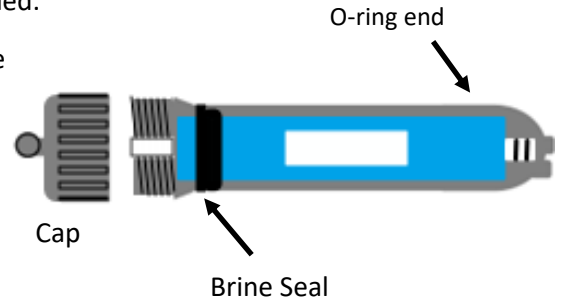

System SKU	Tank	Membrane	Flow restrictor
PRO-41110-A	3.2	25 GPD	220 ml/min
PRO-41120-A	4.5	25 GPD	220 ml/min
PRO-41310-A	3.2	50 GPD	420 ml/min
PRO-41320-A	4.5	50 GPD	420 ml/min
PRO-41410-A	3.2	75 GPD	650 ml/min
PRO-41420-A	4.5	75 GPD	650 ml/min

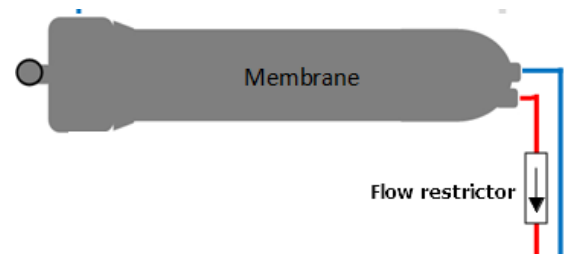

## Storage Tank Assembly and Prep

1. Apply 3-4 wraps of Teflon® tape to the tank threads and thread tank valve on to the tank. DO NOT OVER TIGHTEN!
2. Connect 3/8" white tubing from tee connected to inlet port (on back) of the post filter housing
3. Using a low pressure bicycle tire gauge, check that the empty tank precharge is 7-8 psi. Adjust accordingly if needed.

**NOTE: Tank pressure must be at 7 psi before the permeate pump will operate. If the empty tank pre-charge pressure is below 7 psi, the tank will have to fill with enough RO water to reach 7 psi before the permeate pump will operate.**

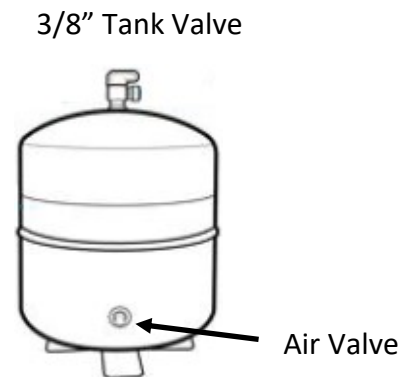

## Permeate Pump

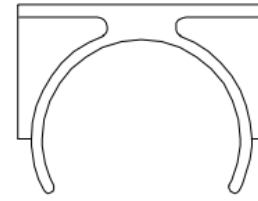
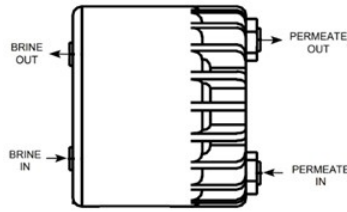
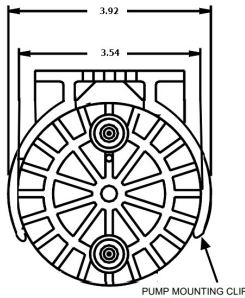

#3

## Permeate Pump Installation

1. It may be necessary to trim tubing to ensure a proper fit of pump in the bracket with out ports on top.
2. The permeate pump snaps into the black mounting clip already assembled to the bottom of the mounting bracket between the pre and post filter housings. (#3 above) Orient the pump so the OUT ports are at the top (12:00) after the pump is snapped into the bracket.
3. Locate the blue tubing hanging between the housings that is attached to the ASO (Auto Shut-Off) Push the stem elbow on the other end into the PERMEATE OUT port. The other blue tube will connect to the PERMEATE IN port
4. Locate the red tubing hanging between the two housings that is connected to the membrane housing and flow restrictor. This connects to the BRINE IN port. Once the air gap faucet is installed, the red 1/4" tube from the faucet air gap attaches to the BRINE OUT port.

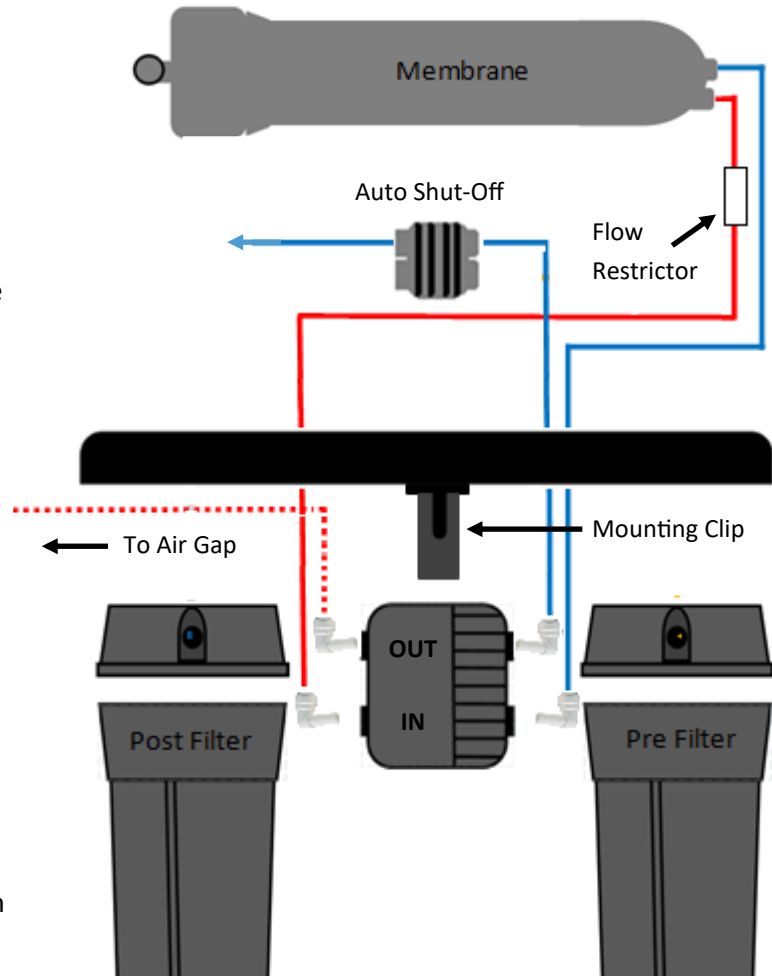

## Outlet Elbow Assembly

The post filter outlet requires the stem adapter and elbow be installed. These parts are in the install kit bag to avoid shipping damage.

1. Apply 3-4 wraps of Teflon tape to the threaded end of the stem adapter and screw into the threaded port of the post filter be careful to not over tighten.
2. Once the stem adapter is securely in place, push the elbow onto the stem so the collet is all the way down on the stem



## Installation Diagram

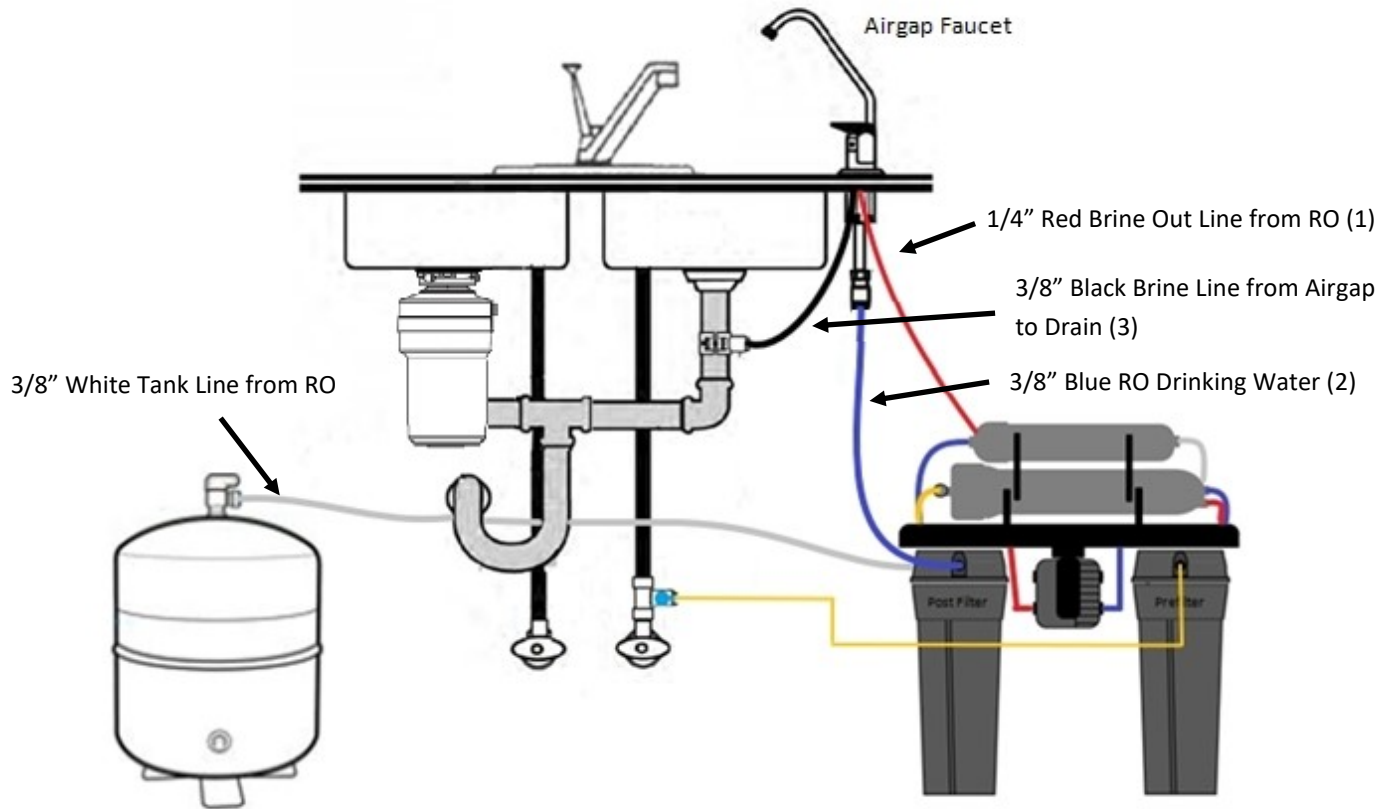

### Installation Notes:

Under a standard sink base cabinet is usually plenty of room for the water system. The airgap faucet and drain installations are described later in this manual. The RO system is best mounted to the side wall of the cabinet with about 3" of clearance to the cabinet floor to make it easier for filter changes.

There are five tubing connections to make once the location has been determined;

- The feed supply line connects the feed supply adapter (page 11) to the front of the prefilter on the right. (1/4" yellow tube)
- The tank line connects the tank valve with the tee located behind the post filter (3/8" white tube)
- It is best to attach all of the tubes to the faucet prior to installing it. Then feed the tubes down through the installation hole for the faucet. Finish the faucet mount and connect the tubing to the following:
  - (1) - 1/4" Red tube goes on the small barb on the faucet base and connects to BRINE OUT port
  - (2) - 3/8" Blue drinking water line connects to the stem of the faucet and the outlet port of the post filter
  - (3) - 3/8" Black tube goes on the large barb under the faucet base and connects to the drain saddle. This run must be as straight as possible without dips or bends.

**Tip:** To make it easier to push the tubes onto the barbs, pour a cup of near boiling hot water and soak the ends of the red brine tube and the black tube in the hot water for a few minutes. This will soften the tubing enough to smoothly slide on to the barb. As the tube cools it will conform to the barb for a better fit.



## System Components and Replacements

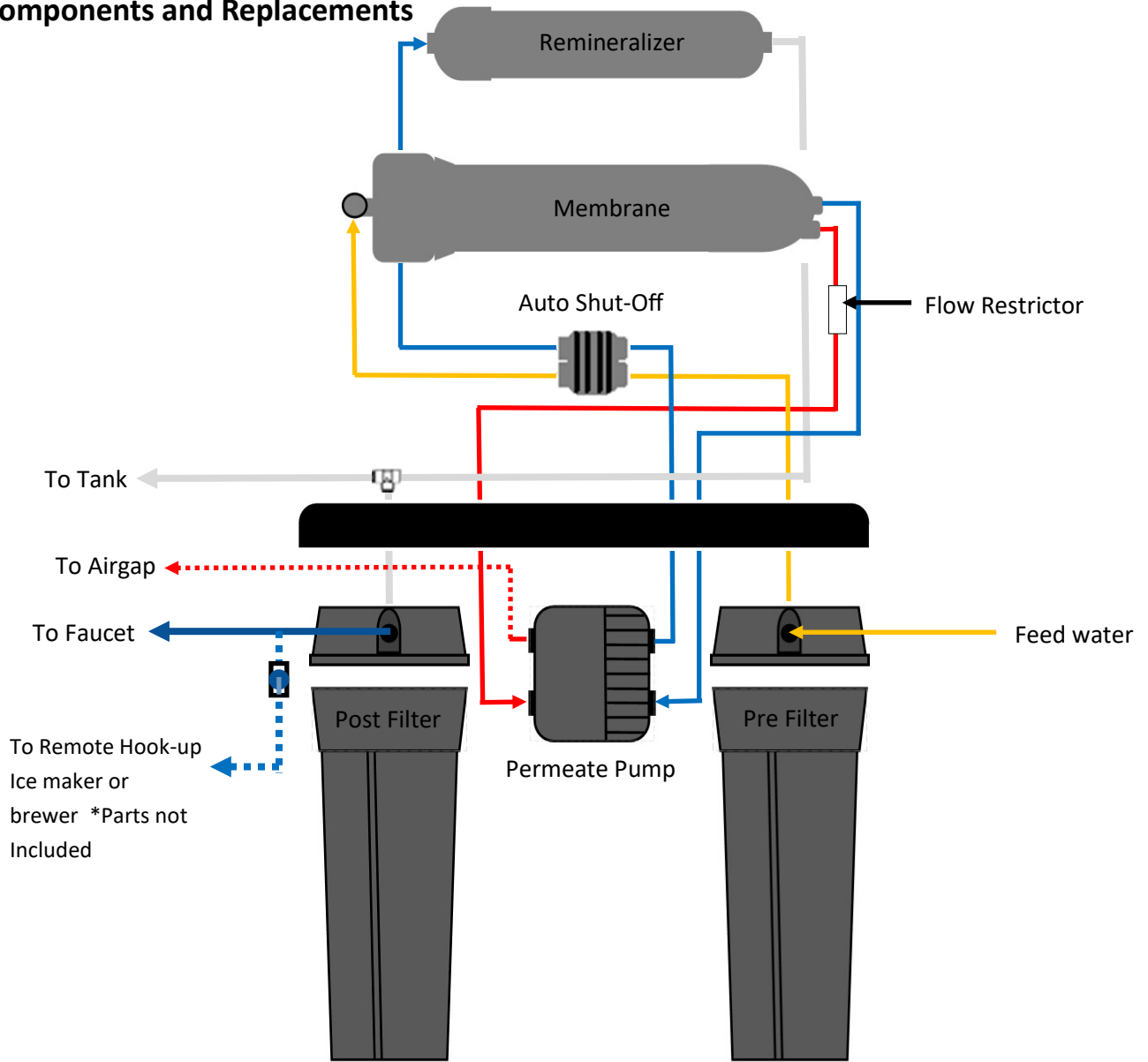

\*Assembled with NSF Certified components

Part Number	Description
CTO1-2510	Prefilter
CTO1-2510	Post filter
ERP-500	Permeate Pump
S3000HCB	ASO Valve
IL2512-57-4Q	Remineralization Cartridge
OR-FHSL-N	Housing O-Ring

Part Number	Description
NP-TW1812-25	25 GPD Membrane
FRIL86-220-4Q	Flow Restrictor (25)
NP-TW1812-50	50 GPD Membrane
FRIL86-420-4Q	Flow Restrictor (50)
NP-TW1812-75	75 GPD Membrane
FR-650-JG	Flow Restrictor (75)

Filter Kit Replacements		Pre Filter	Post Filter	Remineralizer	Membrane
PRO-FK-1125A	25 GPD	CTO1-2510	CTO1-2510	IL2512-57-4Q	NP-TW1812-25
PRO-FK-1150A	50 GPD	CTO1-2510	CTO1-2510	IL2512-57-4Q	NP-TW1812-50
PRO-FK-1175A	75 GPD	CTO1-2510	CTO1-2510	IL2512-57-4Q	NP-TW1812-75

## Location and Installation of the Drain Saddle

Here are a few tips to use when deciding the location and installing:

- **Place the drain saddle as far away from a disposal as possible.** A disposal can shoot debris into the drain line and block the air gap. Locate a place where tubing can run as straight as possible without looping or extreme bending.
- **Adjust excess tubing** that dips below the saddle location that causes water to back up the air gap and leak out.
- **Keep the drain saddle from rotating away from the drilled hole.** Here's how: apply the clamp, tighten it, then drill the hole. Be careful not to damage the tube connection fitting. Rotation can also occur over time if your system under the sink gets bumped.
- **Use a horizontal mount** to minimize the gurgling noise your RO system makes while filtering water. The location of the saddle drain may also help.
- **Never position on the wall side of the P-Trap.** The P-Trap is there to keep sewer gas from coming out your sink drain. Placing the saddle on the back side of the p-trap will allow the sewer gas to come out the airgap hole!

**Clear accumulated debris** by taking the tubing apart from the saddle. During the cleaning process, make sure the hole is properly lined up with the clamp. Insert a pencil or small screwdriver through the fitting to ensure proper alignment.

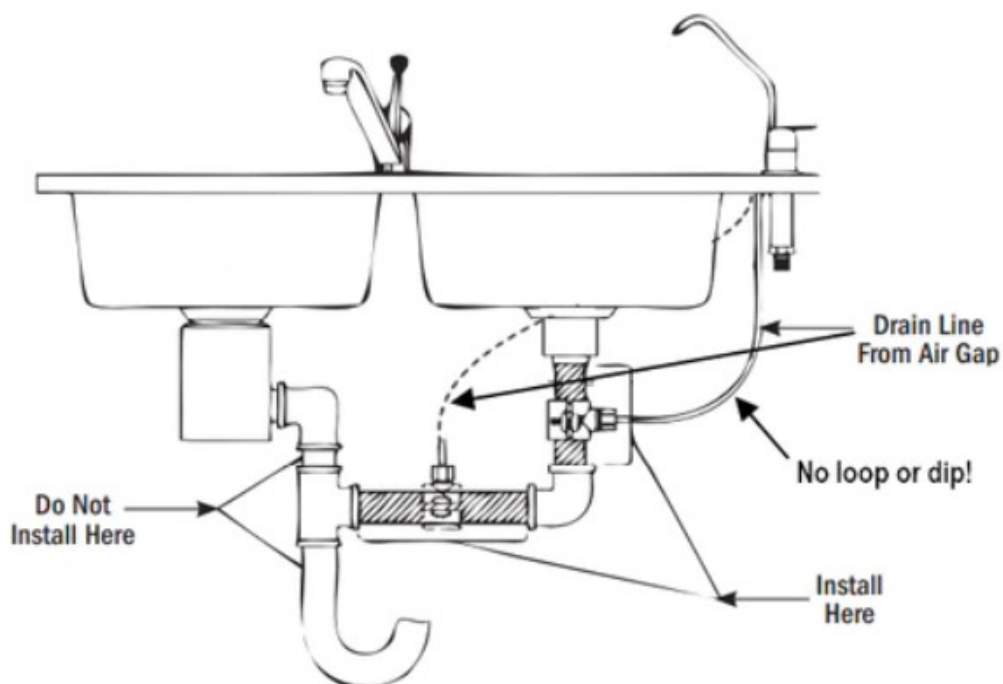

## Drain Saddle Installation Steps

1. Position the drain saddle in the desired location, mark the spot to be drilled and remove the saddle.
2. Drill a 7/16" hole through just one side of the drain pipe.
3. The drain saddle comes with a self adhesive foam pad. Peel off the backing and apply to the inside of the saddle with the tube connection fitting.
4. Attach the saddle parts around the pipe being sure to line up the drilled hole with the saddle port. (hint) place a pencil through the saddle's hole and into the drilled drain line as you tighten the parts together with the two bolts.
5. The 3/8" tube from the air gap faucet will connect to this part. Trim it to fit so that the run from the faucet barb and the drain saddle is as straight as possible.

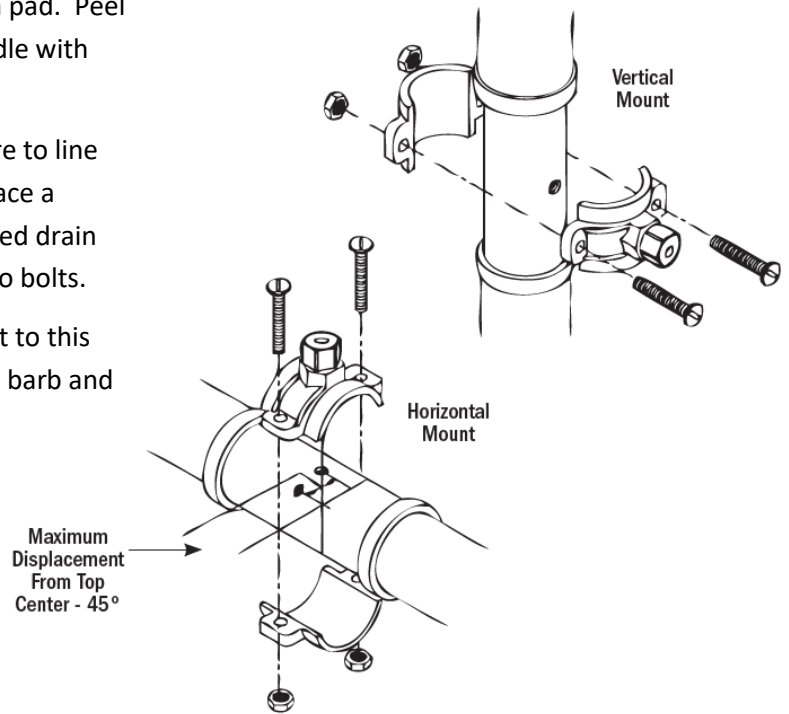

## Feed Supply Valve Installation

Note: This adaptor is designed to fit 3/8" compression supply threads and has adapters for 1/2" NPS connections

1. Locate the cold water supply valve (shut-off) under the sink. Turn off the cold water supply.
2. Turn on the kitchen faucet. This will release pressure and allow water to completely drain from the line.
3. Disconnect the cold water feed supply line from the top of the cold water supply valve. (Angle stop valve)
4. Holding the Angle Stop Valve Adapter in an upright position, thread the female side of the faucet adapter on to the cold water supply valve.
5. Attach the cold water supply line for the faucet to the male - top side of the adapter.
6. Occasionally, The adapter will have to be located at the base of the base of the cold water side of the sink faucet and the reason for the 1/2" NPS adapters.

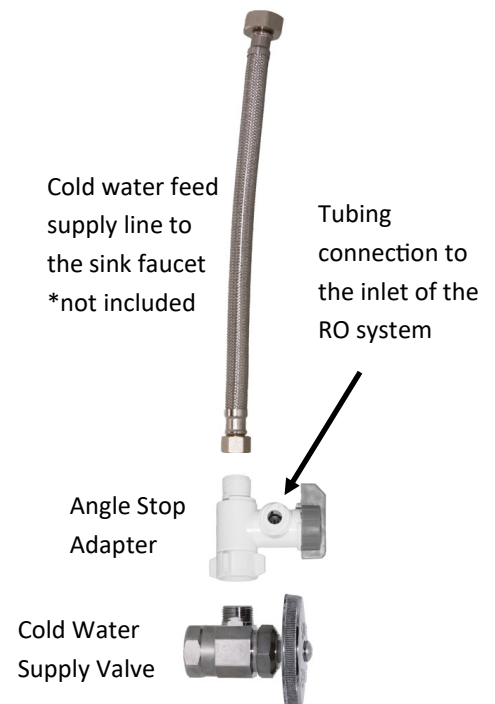

Angle Stop Adapter shown with 1/2" NPS adapters

## Air Gap Faucet Installation

Installation of the Air Gap Faucet is a required part of installation and is the system's means of drain water backflow prevention. If sink top includes an unused knockout hole, remove knockout cover plate and mount faucet there. If no knockout hole exists, drill 1.25" diameter mounting hole in sink top using 1.25" hole saw and drill motor. Sink material will determine drilling method. Faucet should be positioned so it empties into sink and spout swivels freely for convenience. Before drilling mounting hole, check underneath sink to ensure nothing will interfere with Air Gap Faucet plumbing such as reinforcement ribs, support brackets, or other under-sink construction.

**CAUTION:** To prevent eye injury, safety glasses must be worn during sink drilling operation.

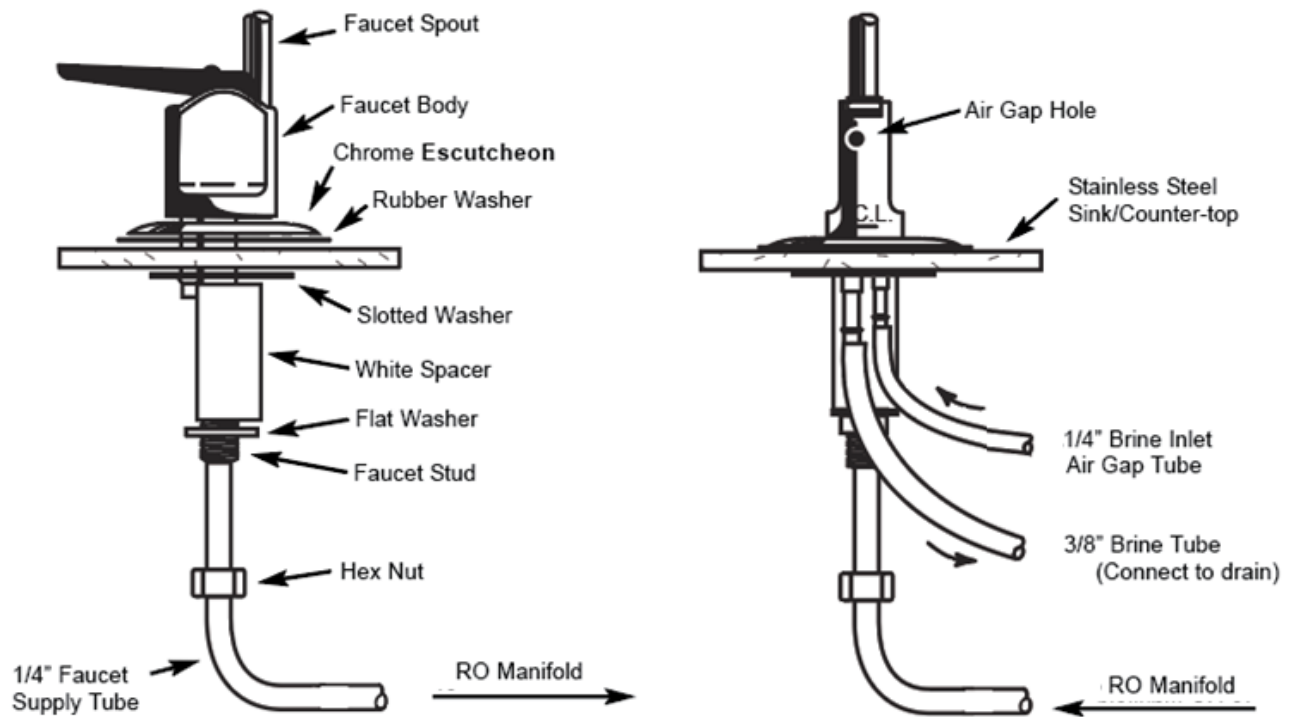

Figure 2

- Review components shown in Air Gap Faucet diagram (Figure 2).
- Attach the tubing to the faucet . Red 1/4" tubing and black 3/8" to the barbs under the faucet base and the blue 3/8" tube to the faucet adapter on the stem. Make sure the hex nut is on the stem above the adapter first.
- From above sink/counter-top, feed tubing and remaining mounting hardware on faucet stem through the 1.25" diameter mounting hole
- Position faucet spout over sink
- Loosen hex nut further and insert the slotted washer between the white spacer and underside of the counter. Place the open side of slotted washer towards air gap tubes.
- After rechecking the faucet orientation, tighten the hex nut with a 9/16" wrench until the faucet is securely mounted.

## Final Tubing Connection

With all system components now properly installed, final tubing connection can be completed.

This product is outfitted with user friendly “Push-In” connectors. Proper use of “Push-In” connectors is shown in Figure 9. Tubing selected for use with connectors should be of high quality, exact size and roundness, and have no surface nicks or scratches. If it is necessary to cut tubing, use tubing cutter tool or sharp razor knife. Make clean square cuts on ends of all tubing. Should a leak occur at a “Push-In” connector, the cause is usually the tube is not pushed in far enough or the end of the tube is compromised.

### How to Use Quick Connect / Push to Fit Fittings

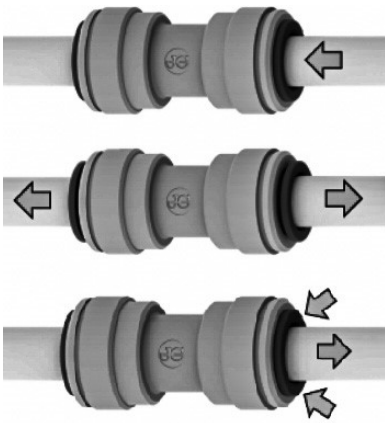

**To Install:**

- Cut tubing Square - Remove burrs and sharp edges. Ensure the outside diameter is free of scratches.
- Push the tube into the fitting all the way to tube stop. (measure 3/4" up tube and make a line. Push tubing in so that line is even or below the collet)
- Pull to check it is secure and test the system for leaks before use

**To Disconnect:**

- Ensure the system is off and depressurized, push the collet square against the fitting body. With collet held in this position, the tube can be removed

Figure 3

#### To remedy leaks at push in connections:

- Make sure the tubing is pushed all the way in. If uncertain, measure 3/4" and mark the end of the tube. It is pushed in all the way if the line disappears into the fitting:
- If tubing is in far enough and still leaks, check to make sure there are no deep scratches and the end of the tube is smooth. If not, cut back 1" nice and square and re-insert

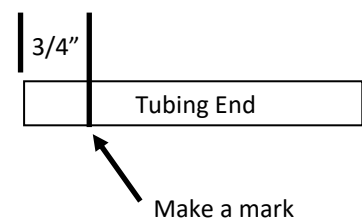

## System Start-up

1. Check all connections and ensure they are secure.
2. Turn on the feed water valve and check for leaks. (Turn off and correct leaks if any occur)
3. Close the valve on the storage tank and open the faucet until a steady fast drip or stream of water flows. (The higher the selected membrane output, the more water will flow) Water will be flowing to the drain as well. NOTE: The permeate pump will not start working until the tank valve is opened and the tank reaches 7 psi.
4. Once there is a steady fast drip or stream of water coming from the faucet, close the faucet and wait five minutes to see if any leaks result on the system. The initial water from the system may be slightly discolored. This is normal.
5. If there are no leaks, open the storage tank valve and allow the system to fill. Most systems will be full within 2-3 hours depending on feed pressure, membrane output, and tank size. The system is full when the water to the drain stops. Check for leaks with the system full and repair them accordingly. NOTE: When the system is first turned on, water may intermittently "spurt" from the air gap opening on the side of air gap faucets. This is common and should correct itself after the air is purged from the system. CAUTION: Ensure that the system is not being fed with water above 75 PSI or damage to the system could occur.

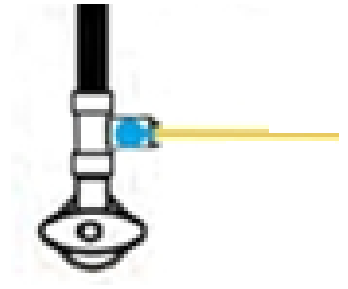

## System Routine Maintenance

Periodic maintenance is needed on any water filtration appliance. The PRO-41000A is equipped with filters, a membrane and a remineralization cartridge that will all require replacement from time to time to ensure that the system continues to produce very high quality water.

Filter life is dependent on water usage as well as water conditions at the installation site. Carbon filters have a definite exhaustion point. With a family of four with frequent use, the carbons and remineralizer should be replaced every six months. A smaller family with less frequent use replacing them annually may be sufficient.

Membrane life will be extended if water is softened first. Non softened water will shorten replacement cycles but typical membrane life is 2-3 years before needing to be replaced.

Filter Kit Replacements		Pre Filter	Post Filter	Remineralizer	Membrane
PRO-FK-1125A	25 GPD	CTO1-2510	CTO1-2510	IL2512-57-4Q	NP-TW1812-25
PRO-FK-1150A	50 GPD	CTO1-2510	CTO1-2510	IL2512-57-4Q	NP-TW1812-50
PRO-FK-1175A	75 GPD	CTO1-2510	CTO1-2510	IL2512-57-4Q	NP-TW1812-75

## System Routine Maintenance

### Changing the Carbon Pre and Post Filters

1. Turn off the ball valve on top of the storage tank 1/4 turn clockwise. (Page 6).
2. Turn off the feed (cold) water supply valve. (Page 8).
3. Open the handle on the dispensing faucet and wait a few minutes for the pressure to be relieved from the RO system.
4. Remove the Filter housing by turning it counterclockwise (as viewed from the bottom). If you encounter difficulty, use the filter wrench provided with your RO.
5. Discard the old filters
6. Wash out the filter housing using warm, soapy water and rinse thoroughly.
7. Be sure the O-Ring is properly seated in the groove that is located in the top of the filter housing and lubricated with silicon based lube.
8. Insert the new Filter into the housing and rotate the housing back on to the cap clockwise. Be careful to allow the top of the filter to properly engage the inside off the cap for a proper seal. Hand Tighten to snug.

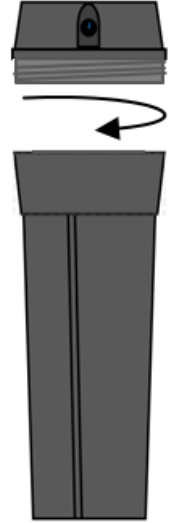

### Changing the Membrane

1. If just changing the membrane and not the pre and post, Follow steps 1 through 4 above.
2. Detach the tubing connection on the pressure vessel end cap.
3. Remove the pressure vessel end cap by turning counterclockwise.
4. Remove the membrane, use needle nose pliers to grab the product tube and pull the membrane out of the housing.
5. Insert the new membrane, making sure that the brine seal and the product water O-Rings are fully seated.
6. Replace the end cap by turning clockwise.
7. Reattach the tubing to the pressure vessel end cap.

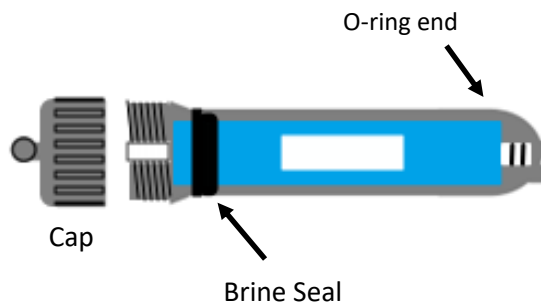
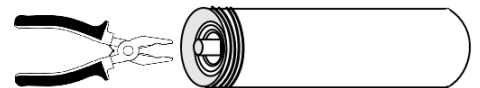

## System Routine Maintenance

### Changing the Remineralization Cartridge

The cartridge has 1/4" quick connect fittings on each end so replacing it is pretty simple. Refer to the how to use quick connect fittings guide on page 13.

1. Release the elbow fittings from each end of the cartridge then remove it from the mounting clips.
2. Snap the new cartridge in to the mounting clips paying attention that the flow direction arrow on the cartridge is pointing left to right.
3. Plug the elbows into the new cartridge making sure they press in all the way.

### Repressurize system

1. Turn on the feed water valve and check for leaks. (Turn off and correct leaks if any occur)
2. Close the valve on the storage tank and open the faucet until a steady fast drip or stream of water flows. (The higher the selected membrane output, the more water will flow) Water will be flowing to the drain as well. NOTE: The permeate pump will not start working until the tank valve is opened and the tank reaches 7 psi.
3. Once there is a steady fast drip or stream of water coming from the faucet, close the faucet and wait five minutes to see if any leaks result on the system. The initial water from the system may be slightly discolored. This is normal.
4. If there are no leaks, open the storage tank valve and allow the system to fill. Most systems will be full within 2-3 hours depending on feed pressure, membrane output, and tank size. The system is full when the water to the drain stops. Check for leaks with the system full and repair them accordingly. NOTE: When the system is first turned on, water may intermittently "spurt" from the air gap opening on the side of air gap faucets. This is common and should correct itself after the air is purged from the system. CAUTION: Ensure that the system is not being fed with water above 75 PSI or damage to the system could occur.

## Sanitizing the Storage Tank

Periodic sanitization of the storage tank is an often missed step in the overall maintenance of reverse osmosis systems. We have created a kit made up of 4 thumb latch style quick disconnect fittings to make the process of sanitizing incredibly easy so the step will not be missed.

The Kit consists of 4 fittings, a packet of Sani system, a tank pressure gauge, and a plastic syringe.

Once the fittings are installed, sanitizing the tank takes just a few minutes and during filter change outs, specifically membrane change outs the tank sanitization process is so simple it makes good sense to get it done. The tank pressure gauge allows you to keep track of the empty tank precharge pressure to ensure proper tank function.

Use this OCR code to order your kit today:

Order additional packs of Sani system when ordering replacement filters

- Kit with fittings: SANI-101
- Sanitizer packet: SANISYSTEM-RO



# Tank Sanitation Kit for PRO-41000A RO Systems

## Installation Instructions

1. Close the feed supply valve
2. Close the tank valve
3. To relieve pressure, open the RO faucet until water flow stops
4. Cut tubing from feed line
5. Install valved insert (1) closest to feed supply valve
6. Install body (3) closest to the RO inlet
7. Cut tubing from tank line
8. Install body (4) closest to the tank valve

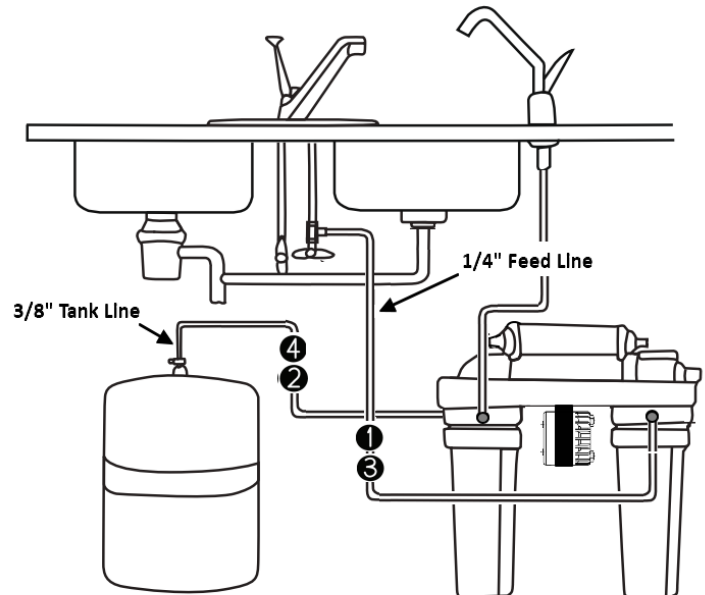

## Sanitizing Steps

1. Close feed supply valve to the RO unit and open RO faucet to allow all water to empty from the storage tank.
2. Close tank valve and disconnect the body (4) from the non-valved insert (2). Shake as much water as you can from the tube.
3. Fill the syringe with the liquid sanitizer and empty it into the coupling body (4) so that it enters the tank through the tubing.
4. Connect the body (4) to the valved insert (1).
5. Open tank valve and feed supply valve and allow the tank to fill for several minutes. If using Sani System, you only need to let the water sit for 60 seconds once the tank is full.
6. Close the tank valve. Reconnect the couplings to their original positions, install valved insert (1) to body (3), and non-valved insert (2) to body (4). Then open the RO faucet to empty the tank.
7. Close the RO faucet and allow system to fill the tank. This should take 3 to 4 hours.

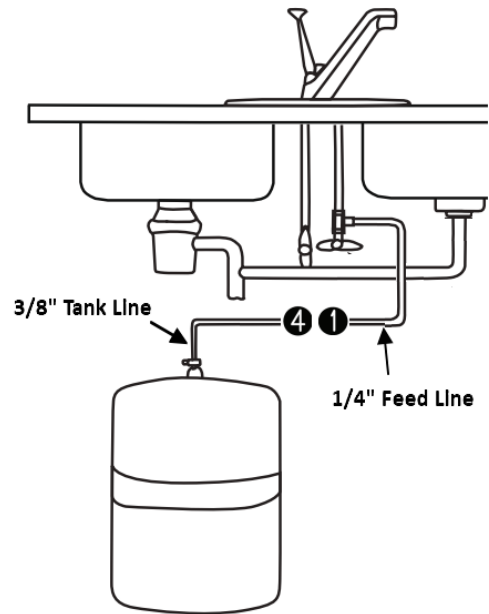

## Troubleshooting

### Not Enough Water From The Storage Tank

Possible Cause	Solution
Feedwater valve is plugged or closed.	Open valve or unclog.
Pre or post filter is clogged	Replace filters
Low feed water pressure	Water pressure should be above 50 psi. Install a booster pump
RO Membrane is fouled	Make sure drain line is not clogged. Correct fouling cause, replace membrane
Air pressure in storage tank is not correct	Empty water from tank. Adjust empty tank precharge to 5-7 psi
Air bladder in tank has failed	Replace the storage tank
Tank valve is closed (off)	Open the valve
Drain flow is too high	Check that flow restrictor is correct for the membrane - replace restrictor

### Low Water Pressure from Drinking Water (RO) Faucet

Possible Cause	Solution
Air Pressure in storage tank is incorrect	Open faucet and empty water from storage tank. Shut off feedwater to the system and remove the tank from under the sink (much easier to work on)  Locate the air valve and add air. If there is still water in the tank, continue to add air until the water is out. Once water is out adjust the empty tank air pressure to 5-7 psi. Reinstall the tank under the sink and turn feedwater back on and allow the tank to fill
Carbon post filter is clogged	Replace filter
Tank valve is partially closed	Open valve all of the way
Low water production	See section above on not enough water from storage tank

### Poor Water Quality - High TDS, Bad Taste or Odors

Possible Cause	Solution
RO Membrane is expended	If membrane life is unusually short, find and correct the problem. (High hardness, iron or manganese in the feed water) Avg membrane life is 2-3 years. Replace the membrane.
Low feedwater pressure	Water pressure should be 50 psi or better. Add a booster pump
Pre filter clogged preventing good pressure	Replace the filter
Dissolved gas in feedwater (Rotten egg smell)	Well water - Pretreat feedwater to remove gasses
Change in feedwater quality - Worsens	Pre-treat issues
No water moving to drain	Drain flow restrictor is clogged - replace it

### Drain water coming from Faucet air-gap

Possible Cause	Solution
Drain line is clogged	Clear or replace tubing - check that drain pipe is clear
New Install	Too much tubing used from airgap connection to drain line (see page 10)



## Neo-Pure PRO-41000A Series Limited Warranty

**What Does This Warranty Cover?** This warranty covers any defects in materials and workmanship of the Neo-Pure® PRO-41000A Series High Efficiency Reverse Osmosis Drinking Water System when installed and operated within recommended parameters, with the exceptions stated below.

**How Long Does the Coverage Last?** NeoLogic Solutions will warrant its R.O. Drinking Water System (except for the reverse osmosis membrane), for a period of five years from the date of purchase. The reverse osmosis membrane is warranted for one year from date of purchase. All implied warranties including merchantability and fitness for a particular purpose are limited to five years from the date of purchase for the R.O. Drinking Water System, except for the reverse osmosis membrane which is limited to one year from date of purchase. Some states do not allow limitations on how long an implied warranty lasts, so the above limitations may not apply to you.

**What Will NeoLogic Solutions Do?** NeoLogic Solutions will repair or replace at its discretion any defective component. You must pay any labor charges. You must also pay for shipping or travel charges to return the defective part(s).

**What Does This Warranty Not Cover?** This warranty does not cover the disposable sediment and carbon filters whose service life depends on feed water conditions. In addition, the membrane is only warranted if the required feed water conditions are met.

The above warranty will also not apply to any part of the Neo-Pure R.O. Drinking Water System that is damaged because of neglect, misuse, alterations, accident, misapplication, physical damage, or damage caused by fire, acts of God, freezing or hot waters or similar causes. Consequential and incidental damages are not recoverable under this warranty. Some states do not allow the exclusion or limitation of incidental or consequential damages, so the above limitation or exclusion may not apply to you.

We recommend that you use only authorized Neo-Pure replacement parts since improper parts or incorrectly performed maintenance or repair voids this warranty. In addition, if non Neo-Pure parts are used, contaminant reduction claims and/or state approvals are no longer valid.

**How Does State Law Apply?** This warranty gives you specific legal rights and you may also have other rights which vary from state to state.

Distributed By:



2299 Ridge Rd., Greenville, SC 29607

Call: 888.859.1188 • Email: [info@NeoLogicSolutions.com](mailto:info@NeoLogicSolutions.com) • Visit: [NeoLogicSolutions.com](http://NeoLogicSolutions.com)

All Rights Reserved. Manufacturer reserves the right to make changes without notice. ©2019 NeoLogic Solutions

Distributed By:



2299 Ridge Rd., Greenville, SC 29607

Call: 888.859.1188 • Email: [info@NeoLogicSolutions.com](mailto:info@NeoLogicSolutions.com) • Visit: [NeoLogicSolutions.com](http://NeoLogicSolutions.com)

All Rights Reserved. Manufacturer reserves the right to make changes without notice. ©2019 NeoLogic Solutions