

REVISIONS						
SHEET	ZONE	REV.	ECO	DESCRIPTION	DATE	APPROVED
1	ALL	A	50242	PIN, PIN SPRING AND FORMAT DWG FORMAT	10/25/2017	HRC

**SOCKET BODY,
(ACETAL)**

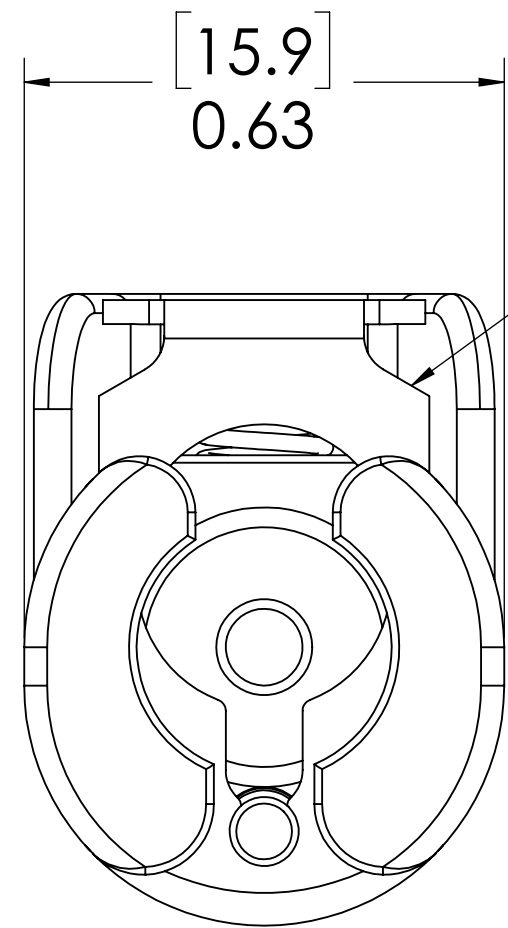

**LATCH HARDWARE,
(STAINLESS STEEL)**

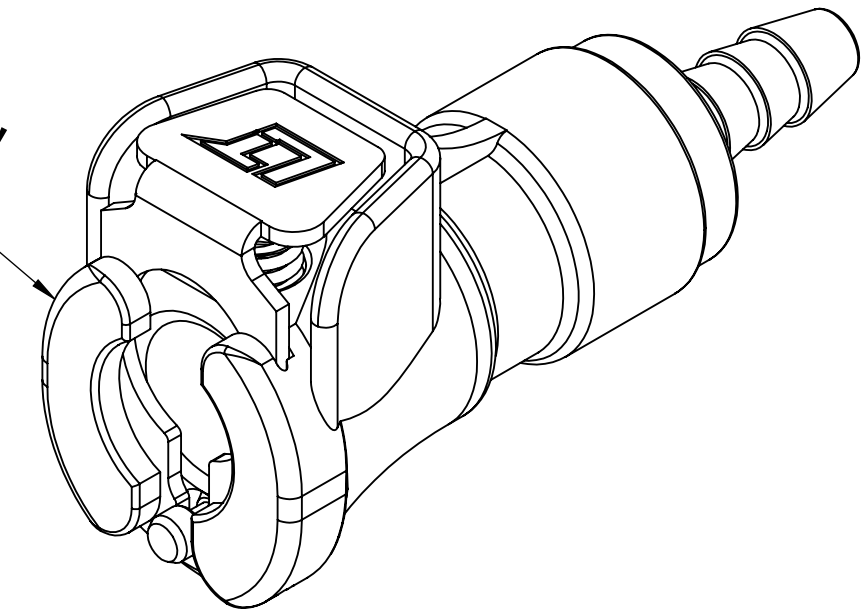
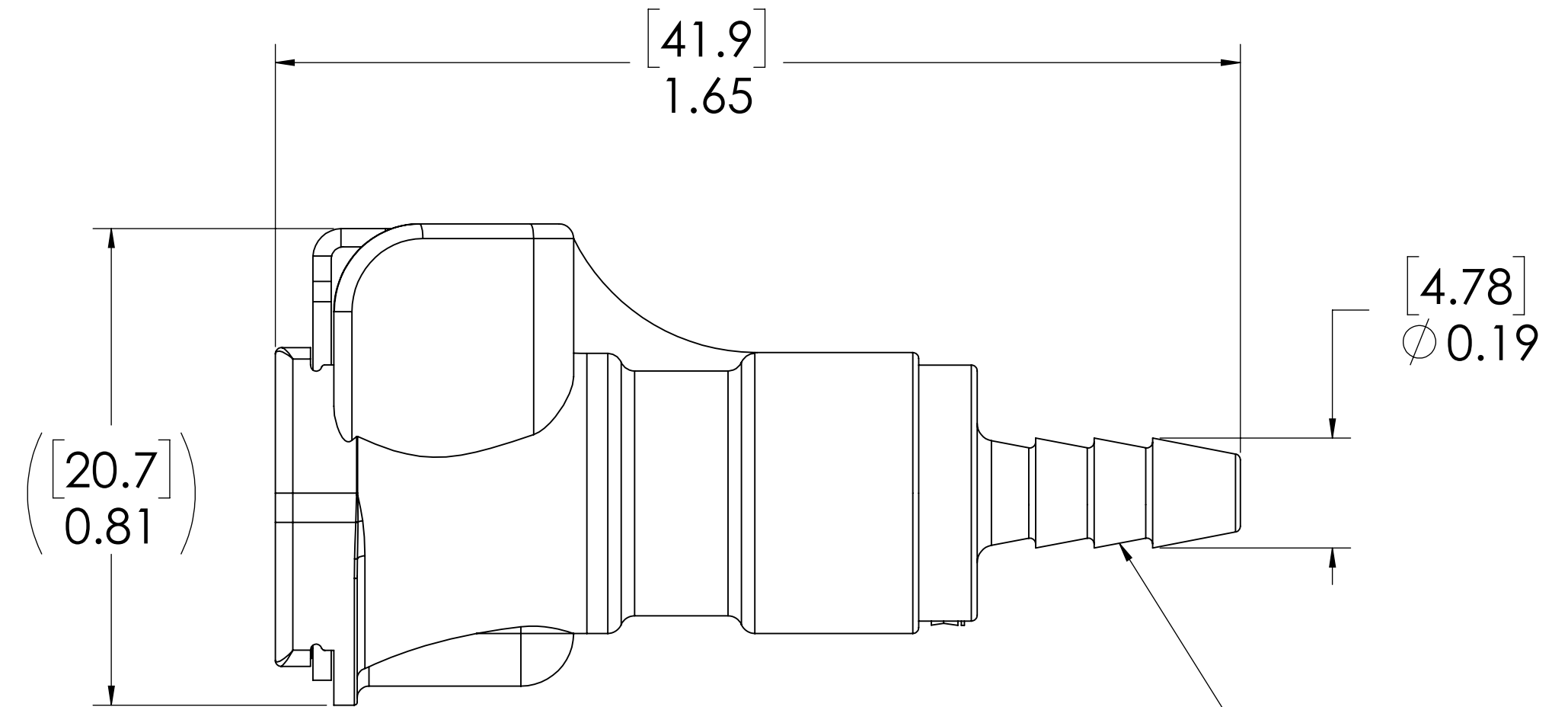

1/8" TUBE ID

NOTES:

1. MATERIAL: ACETAL
2. COLOR: NATURAL WHITE
3. FINISH: HIGH GLOSS

FOR REFERENCE ONLY

<small>UNLESS OTHERWISE SPECIFIED: DIMENSIONS ARE IN INCHES TOLERANCES: FRACTIONAL ± 1/32 ANGULAR: MACH ± 0.5 BEND ± 2 ONE PLACE DECIMAL ± 0.1 TWO PLACE DECIMAL ± 0.01 THREE PLACE DECIMAL ± 0.005 TWO PLACE DUAL (mm) [± 0.12]</small>	DRAWN	RDA	7/10/2017	
	CHECKED	HRC	7/10/2017	
	ENG APPR.	HRC	10/25/17	
	MFG APPR.	BDB	10/25/17	
PROPRIETARY AND CONFIDENTIAL	Q.A.	JJB	10/25/17	PART NO: 20AC-S2-02 DESCRIPTION: LinkTech 20AC Series Straight Female, Non-valved, 125 HB Natural Acetal
<small>THE INFORMATION CONTAINED IN THIS DRAWING IS THE SOLE PROPERTY OF LINKTECH LLC. ANY REPRODUCTION OR DISCLOSURE IN PART OR AS A WHOLE WITHOUT THE WRITTEN PERMISSION OF LINKTECH LLC IS STRICTLY PROHIBITED.</small>			COMMENTS:	
SIZE	DWG. NO.	REV		
	C	20AC200311	A	
SCALE: NTS	WEIGHT:	SHEET 1 OF 1		