

For Residential and Commercial Applications

Job Name _____

Contractor _____

Job Location _____

Approval _____

Engineer _____

Contractor's P.O. No. _____

Approval _____

Representative _____

LEAD FREE*

Series LFN55B Water Pressure Reducing Valves**

Sizes: 1¼" – 2" (32 – 50mm)

Series LFN55B Water Pressure Reducing Valves are designed to reduce incoming water pressure to a sensible level to protect plumbing system components and reduce water consumption. The LFN55B features Lead Free* construction to comply with Lead Free* installation requirements. This series is suitable for water supply pressures up to 300psi (20.7 bar) and may be adjusted from 25 – 75psi (172 – 517 kPa). The standard setting is 50psi (345 kPa). All parts are quickly and easily serviceable without removing the valve from the line. The standard bypass feature permits the flow of water back through the valve into the main when pressures, due to thermal expansion on the outlet side of the valve, exceed the pressure in the main supply.

Features

- Bronze cage
- Double union inlet & outlet connections
- Integral stainless steel strainer
- Thermoplastic seat
- Lead Free* brass body construction
- Serviceable in line
- Bypass feature controls thermal expansion pressure***
- Sealed spring cage on all models for accessible outdoor or pit installations

Models

LFN55B	NPT threaded female inlet x NPT female outlet
LFN55BU	NPT threaded union inlet x NPT female outlet
LFN55BU-S	Solder union inlet x NPT female outlet
LFN55BDU	Double Union – NPT threaded union female inlet and outlet
LFN55BDU-S	Double Union – Solder union inlet and outlet

Specifications

A Water Pressure Reducing Valve and strainer shall be installed on the water service pipe near its entrance to the building where supply main pressure exceeds 60psi (413 kPa) to reduce it to 50psi (345 kPa) or lower. The water pressure reducing valve shall be constructed using Lead Free* materials. Lead Free* regulators shall comply with state codes and standards, where applicable, requiring reduced lead content. Sill cocks and outside wall hydrants may be left on full main pressure at the option of the owner. Provision shall be made to permit the bypass flow of water back through the valve into the main when pressures, due to thermal expansion on the outlet side of the valve, exceed the pressure in the main supply. Pressure reducing valves with built-in bypass check valves and integral strainer will be acceptable. Approved valves shall comply with ASSE 1003. Valve shall be a Watts Series LFN55B.

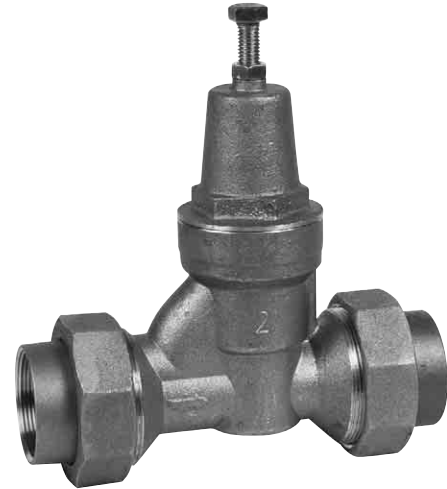

Series LFN55BDU – 2" (50mm) size shown

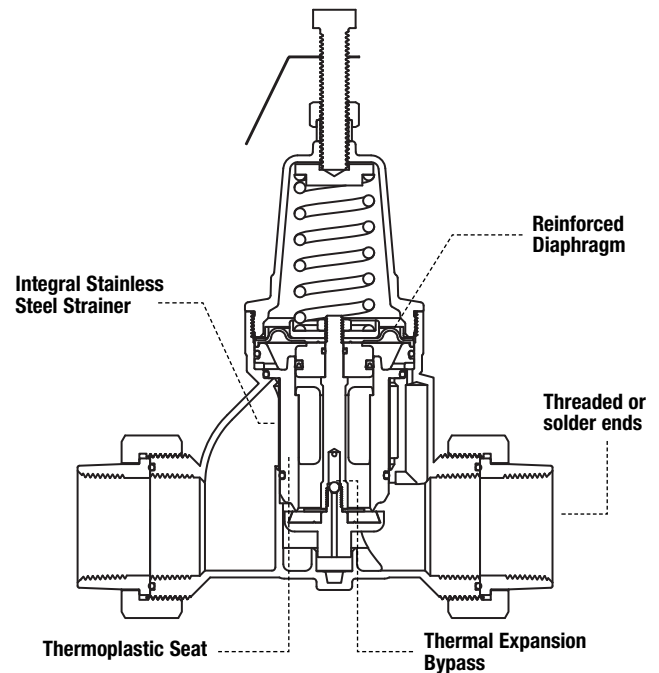

*The wetted surface of this product contacted by consumable water contains less than one quarter of one percent (0.25%) of lead by weight.

**A water saving test program concluded that reducing the supply pressure from 80-50psi (551-345 kPa) resulted in a water savings of 30%.

***The bypass feature will not prevent the pressure relief valve from opening on the hot water supply system with pressure above 150psi (10.3 bar).

Watts product specifications in U.S. customary units and metric are approximate and are provided for reference only. For precise measurements, please contact Watts Technical Service. Watts reserves the right to change or modify product design, construction, specifications, or materials without prior notice and without incurring any obligation to make such changes and modifications on Watts products previously or subsequently sold.

WATTS®

Materials

Body: Lead Free* brass
 Seat: Thermoplastic
 Cage: Bronze
 Integral Strainer: Stainless steel
 Diaphragm: Reinforced EPDM
 Valve Disc: Elastomer

Pressure – Temperature

Temperature Range: 33°F – 180°F (0.5°C – 82°C)
 Maximum Working Pressure: 300psi (20.7 bar)
 Adjustable Reduced Pressure Range: 25 – 75psi (172 – 517 kPa)
 Standard Reduced Pressure Setting: 50psi (345 kPa)

Standards   

Meets requirements of ASSE Standard 1003; (ANSI A112.26.2);
 CSA Standard B356; and listed by IAPMO.

Options

G Gauge tapping
 GG Gauge tapping and 160psi (11.0 bar) gauge

Dimensions – Weights

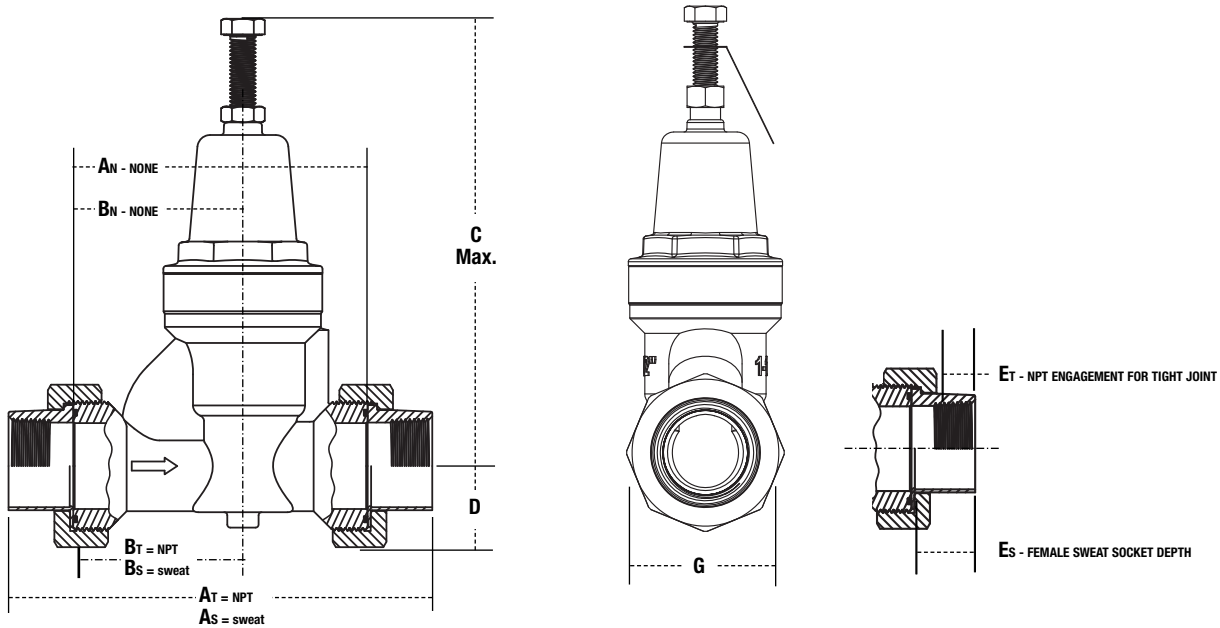

Capacity

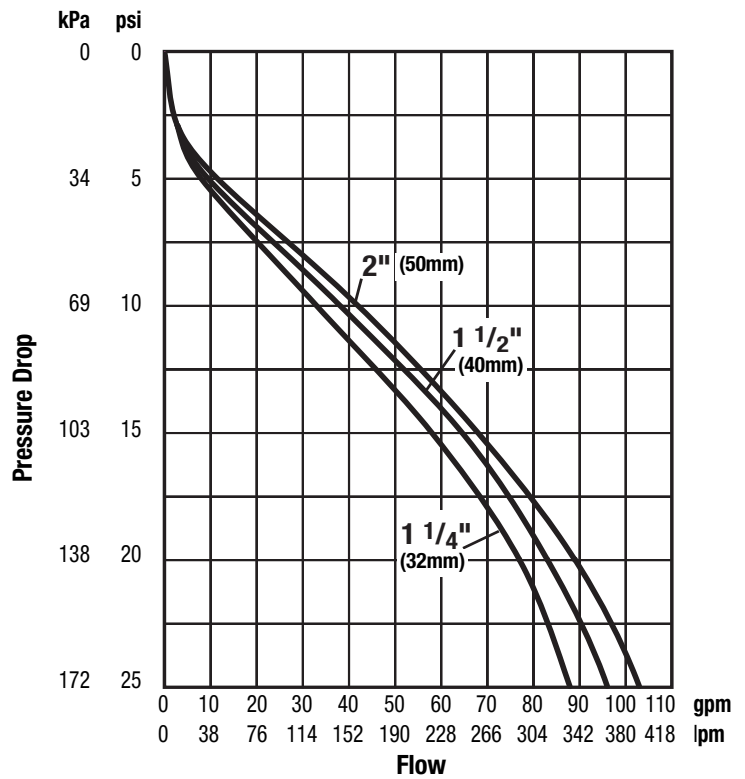

SIZE (DN)		DIMENSIONS										WEIGHTS													
in.	mm	A _T	A _S	A ₁	B _T	B _S	B _N	C	D	E _T	E _S	G	lbs.	kgs.											
1 1/4	32	8 3/8	213	7 15/16	201	5 13/16	148	4 3/8	111	4 1/8	105	3 1/16	78	8 7/8	225	1 7/16	36	1 1/16	17	1	25	3 1/4	82	7.5	3.4
1 1/2	40	8 3/8	213	8 3/16	207	5 13/16	148	4 9/16	115	4 7/16	112	3 1/4	83	8 7/8	225	1 5/8	41	1 1/16	17	1 1/8	28	3 1/4	82	9	4.0
2	50	9	228	9 1/4	235	6 3/8	162	5	126	5 1/16	129	3 1 1/16	93	8 7/8	225	1 7/8	47	1 1/16	17	1 3/8	34	3 1 1/16	93	10	4.5



A Watts Water Technologies Company



USA: 815 Chestnut St., No. Andover, MA 01845-6098; www.watts.com

Canada: 5435 North Service Rd., Burlington, ONT. L7L 5H7; www.wattscanada.ca