



Specifications



GE Infrastructure Water & Process Technologies Merlin™ Reverse Osmosis Systems

System Performance Specifications

Average Permeate Flow Rate → 0.75 Gallons/Minute (2.84 Liters/Minute)
or
1080 Gallons/Day (4,090 Liters/Day)

Average TDS Rejection → 95% NaCl

Based on 3.44 bar (50 psi), 25°C (77°F), 750 mg/L NaCl, 33% recovery

Minimum and Maximum Performance Specifications*

Specification	Minimum	Maximum
Permeate Flow Rate	0.50 Gallons/Minute (1.90 Liters/Minute)	1.0 Gallons/Minute (3.78 Liters/Minute)
TDS Rejection (NaCl)	90%	99%
Concentrate Flow	1.0 Gallons/Minute (3.80 Liters/Minute)	2.0 Gallons/Minute (7.56 Liters/Minute)

Based on 3.44 bar (50 psi), 25°C (77°F), 750 mg/L NaCl, 33% recovery

System Dimensions

Height → 17.05 inch (43.3 cm)
Length → 20.34 inch (51.7 cm)
Depth → 9.68 inch (24.6 cm)

*Pending final product testing





Minimum and Maximum Operating Conditions

Condition	Minimum	Maximum
Inlet Pressure	40 psi (2.76 bar)	80 psi (5.52 bar)
Inlet Temperature	40° F (4.44° C)	100° F (37.78° C)
Inlet TDS	50 mg/L	2,000 mg/L
Inlet Hardness	0 mg/L - (0 grain)	171 mg/L - (10 grain)
Inlet Chlorine	0 mg/L	1.0 mg/L
Inlet Iron	0 mg/L	0.3 mg/L
Inlet Manganese	0 mg/L	0.1 mg/L

*System is designed for use on potable water sources only.

Tubing/Fitting Dimensions

- Inlet Tubing** → 4 feet of 1/2" natural tubing
(1.22 meters of 12.7 mm natural tubing)
- Concentrate Tubing** → 4 feet of 3/8" black tubing
(1.22 meters of 9.53 mm black tubing)
- Permeate Tubing** → 4 feet of 3/8" blue tubing
(1.22 meters of 9.53 mm blue tubing)
- Drain Tubing** → 3 feet of 1/2" red tubing
(0.91 meters of 12.7 mm red tubing)
- Drain Connection** → 1/2"
(12.7 mm)
- Carbon Post Filter** → 3/8" quick disconnect fittings
(9.53 mm quick disconnect fittings)
- Inlet Connection (Option 1)** → 3/8" x 3/8" x 1/2" tee
(9.53 mm x 9.53 mm x 12.7 mm tee)
- Inlet Connection (Option 2)** → 1/2" x 1/2" x 1/2" tee
(12.7 mm x 12.7 mm x 12.7 mm tee)

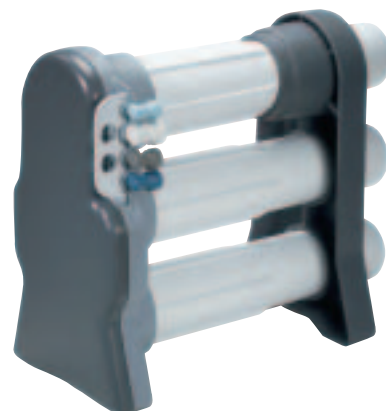



Filter/Membrane Performance Specifications

FILTER TYPE	DIMENSIONS		FLOW RATE	PRESSURE DROP	AVERAGE LIFE
	Length	Diameter			
Carbon Prefilter	17.0"	2.9"	3.75 GPM (14.2 LPM)	3 psi	6 months
RO Element	18.75"	3.16"	0.375 GPM (1.42 LPM)	Pending Final Testing	3 years
Carbon Postfilter	10.5"	2.6"	.750 GPM (2.8 LPM)	Pending Final Testing	6 months

Based on:

50 psi (3.4 bar), 77° F (25° C), 750 mg/L NaCl, 33% Recovery, 1.0 mg/L inlet chlorine

Options

- Booster Pump → For low pressure applications
- Membrane Rinse System → Permeate flushing accumulator
- Ice Maker Installation Kit → Connections to 1/4" ice maker line

Outline Dimensions – Inches (cm)

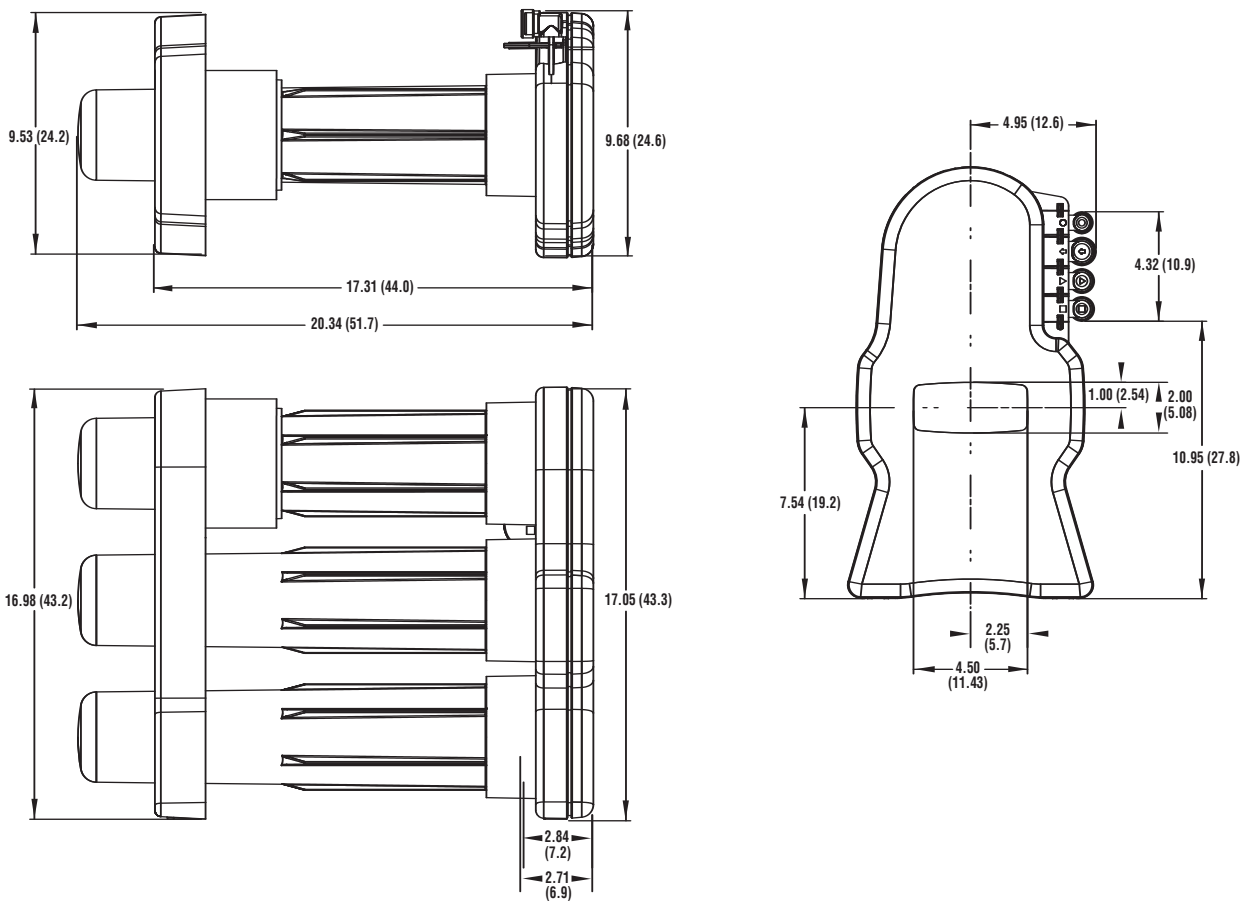



Estimated System Flow Rate (GPM) Temperature vs. Pressure @750ppm NaCl/RO

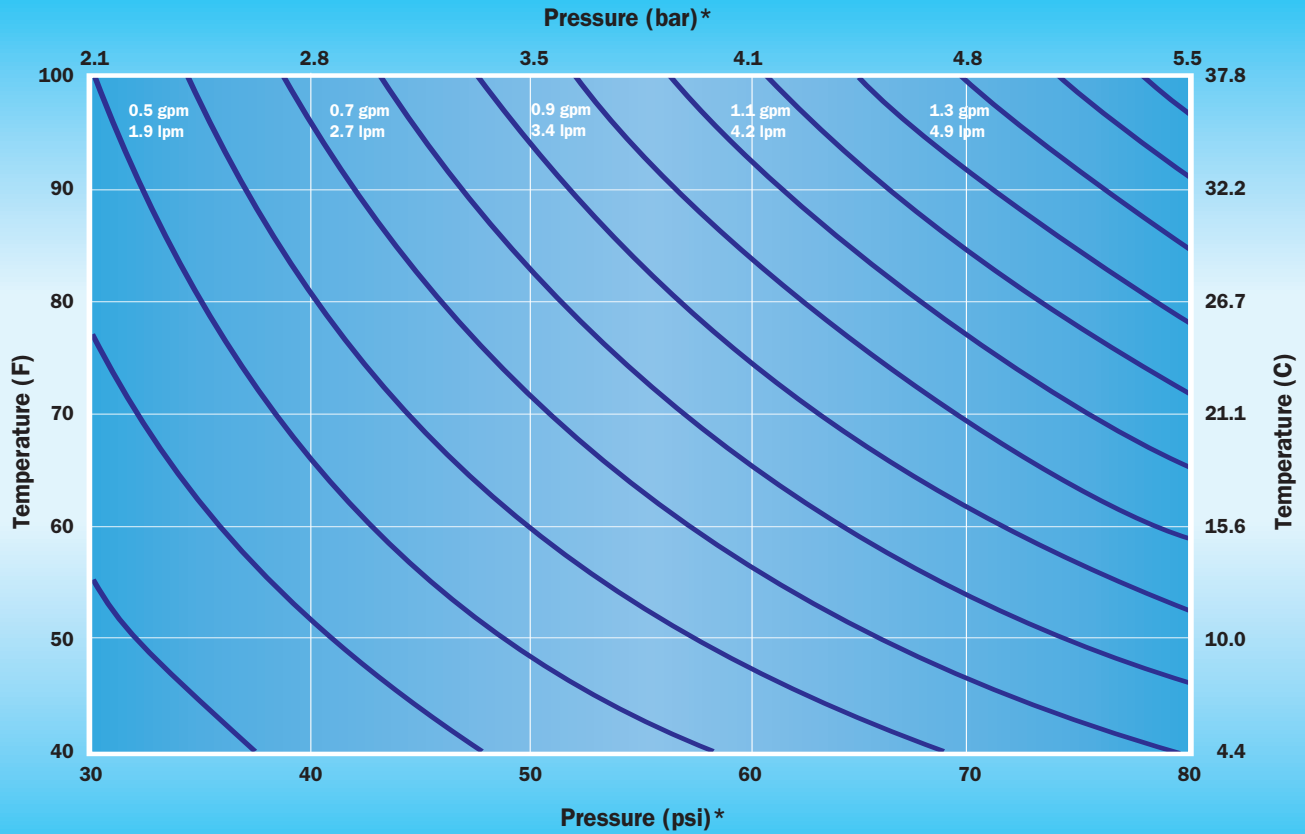

*Pressure measured at membrane element inlet.

Flow Adjustment Based on TDS
Estimated Flow Change from
750ppm NaCl/RO = $-0.0002 \text{ (TDS)} + 0.15$

For More Information:

Call **GE Infrastructure Water and Process Technologies; Household Water Group** at **(262) 238-4400** or **(800) 279-9404**, or visit **www.gewater.com**



North American Sales

5730 N. Glen Park Road
Milwaukee, WI
53209-4403
USA
(262) 238-4400 Phone
(262) 238-4402 Fax

Euro/Africa Operations

230 rue Robert Schuman
ZA des Uselles
F-77350 Le Mée sur Seine
FRANCE
+33 1 64 10 2000 Phone
+33 1 64 10 3747 Fax

Asia/Pacific Operations

1044/8 Soi 44/2
Sukhumvit Road Parkanog
Bangkok 10110
THAILAND
+66 2 38 14213 Phone
+66 2 39 18183 Fax



Merlin™

On-Demand Reverse Osmosis Drinking Water System Model “Merlin I”

Performance Data Sheet



This system has been tested according to NSF/ANSI 58 for reduction of substances listed below. The concentration of the indicated substances in water entering the system was reduced to a concentration less than or equal to the permissible limit for water leaving the system, as specified in NSF/ANSI 58. The substances are: Arsenic, Barium, Cadmium, Chromium (Hexavalent), Chromium (Trivalent), Copper, Fluoride, Lead, Nitrate, Nitrite, Radium 226/228, Selenium and TDS.

This reverse osmosis system contains replaceable components critical for effective performance. It is the user's responsibility to, and the manufacturer strongly recommends that the user, periodically have the product water tested to verify the system is performing satisfactorily by the system's installing dealer every six months. This system shall only be used for arsenic reduction on chlorinated water supplies containing detectable residual free-chlorine at inlet to the system.

If Merlin I filters and membrane elements are not used, health related contaminant reduction claims are invalid.

SPECIFIC CONTAMINANT PERFORMANCE				
Contaminant	Influent (avg. mg/L)	Effluent (ave. mg/L)	Effluent (max. mg/L)	Ave % Reduction
Arsenic ¹	0.049	0.00265	0.00612	94.6%
Barium	11.1	0.189	1.9	98.3%
Cadmium	0.0307	0.0000704	0.0000704	99.8%
Chromium (VI)	0.353	0.00742	0.0147	97.9%
Chromium (III)	0.312	0.000624	0.00453	99.8%
Copper	3.22	0.0721	0.0721	97.8%
Fluoride	8.11	0.51	0.65	93.7%
Lead	0.159	0.000628	0.000628	99.6%
Nitrate/Nitrite (as N) ²	28.96	6.26	7.55	78.4%
Radium 226/228				
Selenium	0.113	0.00249	0.003	97.8%
Total Dissolved Solids (TDS)	726	74.8	94.8	89.7%
<p><i>1 – This system has been tested for the treatment of water containing pentavalent arsenic (also known as As(V), As(+5), or arsenate) at concentrations of 0.050 mg/L or less. This system reduces pentavalent arsenic, but may not remove other forms of arsenic. This system is to be used on water supplies containing a detectable free-chlorine residual at the system inlet or on water supplies that have been demonstrated to contain only pentavalent arsenic. Treatment with chloramines (combined chlorine) is not sufficient to ensure complete conversion of trivalent arsenic to pentavalent arsenic. Please see the Arsenic Facts section of this performance data sheet.</i></p> <p><i>2 – This system is acceptable for treatment of influent concentrations of no more than 27 mg/L nitrate and 3 mg/L nitrite in combination measured as N and is certified for nitrate/nitrite reduction only for water supplies with a pressure of 40 psi (2.76 bar) or greater.</i></p> <p>Testing performed under standard laboratory conditions. Actual results may vary.</p>				

SYSTEM PERFORMANCE RATING:	
Product Water Production:	748 Gallons Per Day (2,831 Liters Per Day)
Average System Recovery:	23.70%
Average System Efficiency:	23.70%
<p><i>Average System Recovery is the percentage of the influent water to the membrane portion of the system that is available to the user as reverse osmosis treated water when operated as designed (without a pressurized storage tank).</i></p> <p><i>Average System Efficiency rating is the percentage of the influent water to the system that is available to the user as reverse osmosis treated water under operating conditions that approximate typical daily usage.</i></p> <p><i>System efficiency rating is identical to recovery rating when the system is tested without a storage tank or when the storage tank is bypassed.</i></p>	

SYSTEM SPECIFICATIONS AND OPERATING PARAMETERS:		
Minimum and Maximum Operating Conditions:		
Inlet Water Condition	Minimum	Maximum
Pressure	40 psi (2.76 bar)	80 psi (5.52 bar)
Temperature	40 F (4.44 C)	100F (37.78 C)
TDS	50 mg/L	2,000 mg/L
Hardness	0 mg/L	171 mg/L
Chlorine	0.0 mg/L	1.0 mg/L
Iron	0.0 mg/L	0.1 mg/L
Manganese	0.0 mg/L	0.05 mg/L
PH	4.0	10.0

Actual system performance will vary depending on varying water temperature and pressure, TDS levels and inlet water chemistry. Operating the system in water conditions outside the minimum or maximum operating parameters may result in reduced system performance and membrane element life.

Note: Do not use with water that is microbiologically unsafe or of unknown quality without adequate disinfection before or after the system. Systems certified for cyst reduction may be used on disinfected water that may contain filterable cysts.

RO SYSTEM & FILTRATION COMPONENTS:

Merlin I RO System: Complete System – Part #1205052

Sediment/Carbon Prefilter: 5 Micron/Activated Carbon Filter – Part #1237460

Membrane Element(s): Thin Film Composite Reverse Osmosis – Part #1238342

Carbon Post Filter: Granular Activated Carbon – Part #1244746

- *Refer to Owner's Manual for installation instructions and servicing/replacement component recommendations.*

WARRANTY:

GE Osmonics Merlin™ Point of Use Drinking Water System Limited Warranty

- A. GE Osmonics (Manufacturer) warrants that the Merlin I drinking water system sold hereunder will be free from defects in material or workmanship at the time of shipment from the GE Osmonics factory. The Manufacturer warrants the Merlin I drinking water system in residential applications for a period of 36 months from the date of manufacture. This warranty does not extend to the system's replaceable components including:
- a. Carbon/sediment prefilter cartridge
 - b. Carbon post filter cartridge/housing
 - c. Merlin I membrane element cartridges will be warranted from a period of 12 months from the date of shipment from the Manufacturer's facility or 18 months from the date of manufacture of the membrane element. The membrane element warranty will not be valid if installed improperly, and must be operated on a chlorine, ozone, bromine and iodine-free domestic water supply in accordance with the published operating parameters for the Merlin I system. The system's prefilter, when used/serviced correctly, will protect the membrane elements from chlorine.
- B. Before using the Merlin I system, the user shall determine the suitability of the product for his/her intended purposes, and shall assume all risk and liability in connection of the system therewith. The Manufacturer shall not be liable for any injury, loss or damage, direct or indirect, special or consequential, arising out of the use of, misuse, misapplication or the inability to use the system.
- C. The Manufacturer's only obligation shall be to issue credit against the purchase or replacement of the equipment proved to be defective in material or workmanship.
- D. The warranty is only applicable if upon demand by the Manufacturer, the Buyer proves to the Manufacturer's satisfaction that:
- a. No repairs or alterations were made to the system or goods without expressed written consent by the Manufacturer.
 - b. The defect is due solely to the materials or workmanship of the goods.
 - c. The defect was not caused by any act of the Buyer or its agents.
 - d. The defect was not caused by any manner beyond the reasonable control of the Manufacturer, including, without limitation, accident or normal wear and tear.
 - e. The system was installed in an application within the published operating specifications for the Merlin I system.
 - f. The system was installed using only supplied or recommended supplier components as described in the Merlin I system documentation.
- E. The warranty does not extend to any goods not manufactured by GE Osmonics even though supplied by GE Osmonics, nor does it extend to any second-hand or reconditioned goods.
- F. If the Merlin I system is used for commercial or industrial purposes, GE Osmonics warrants the Merlin I system will be free from defects in material and workmanship for a period of 12 months from the date manufactured. All other terms of this warranty other than duration shall apply.

ARSENIC FACTS SECTION:

Arsenic (abbreviated As) is found naturally in some well water. Arsenic in water has no color, taste or odor. It must be measured by a lab test. Public water utilities must have their water tested for arsenic. You can get the results from your water utility. If you have your own well, you can have the water tested. The local health department or the state environmental health agency can provide a list of certified labs. The cost is typically \$15 to \$30. Information about arsenic in water can be found on the Internet at the US Environmental Protection Agency website:
www.epa.gov/safewater/arsenic.html.

There are two forms of arsenic: pentavalent arsenic (also called As(V), As(+5), and arsenate) and trivalent arsenic (also called As(III), As(+3), and arsenite). In well water, arsenic may be pentavalent, trivalent, or a combination of both. Special sampling procedures are needed for a lab to determine what type and how much of each type of arsenic is in the water. Check with the labs in your area to see if they can provide this type of service.

Reverse osmosis (RO) water treatment systems do not remove trivalent arsenic from water very well. RO systems are very effective at removing pentavalent arsenic. A

free chlorine residual will rapidly convert trivalent arsenic to pentavalent arsenic. Other water treatment chemicals such as ozone and potassium permanganate will also change trivalent arsenic to pentavalent arsenic. A combined chlorine residual (also called chloramine) may not convert all the trivalent arsenic. If you get your water from a public water utility, contact the utility to find out if free chlorine or combined chlorine is used in the water system.

The Merlin I system is designed to remove pentavalent arsenic. It will not convert trivalent arsenic to pentavalent arsenic. The system was tested in a lab. Under those conditions, the system reduced 0.050 mg/L (ppm) pentavalent arsenic to 0.010 mg/L (ppm) (the USEPA standard for drinking water) or less. The performance of the system may be different at your installation. Have the treated water tested for arsenic to check if the system is working properly.

The RO component of the Merlin I™ system must be replaced every 2-4 years to ensure the system will continue to remove pentavalent arsenic. The component identification and locations where you can purchase the component are listed in the installation/operation manual.



GE Infrastructure Water & Process Technologies

North America Sales

5730 North Glen Park Road
Milwaukee, WI 53209-4454
USA
(262) 238-4400 Phone
(262) 238-4402 Fax

Euro/Africa Sales

230 rue Robert Schuman
ZA des Uselles
F-77350 Le Mee sur Seine
FRANCE
+33 1 64 10 2000 Phone
+33 1 64 10 3747 Fax

Asia Pacific Sales

1044/8 SOI 44/2
Sukhumvit Road Prakanong
Bangkok 10110
THAILAND
+66 2 38 14213 Phone
+66 2 39 18183 Fax