

## **OP350 Advanced Membrane Separation System**

Installation, Operation  
& Maintenance Manual  
Rev. 2.1



**Manufactured By:  
OptiPure**

101 S. Gary Ave  
Roselle, IL 60172

**P: 972.881.9797 F: 972.422.6262**

## General Information

### Safety Warning

Electrical work should be performed by a qualified electrician in accordance with all applicable codes and regulations.

### Service Contact

For local maintenance and service information please contact your nearest Authorized Service Representative. Service inquiries may be directed to technical support at:

OptiPure

101 S. Gary Ave, Roselle, IL 60172

Phone #: 972.881.9797

Fax #: 972.422.6262

E-mail correspondence to:  
techsupport@optipure.net

### Environmental Conditions

The OP350 is certified to operate under the following conditions:

1. Altitude up to 2000 m.
2. Ambient temperature of 40-105°F (5 - 40°C).
3. Max relative humidity 80% at 88°F (31°C).
4. Main supply voltage not to exceed +/- 10%.
5. Installation category II.
6. Pollution degree II.
7. Indoor use only, protect from elements.

### Explanation of Symbols

The following symbols are used on the water processor. The symbols and their explanation is given below:

Earth ground:



WARNING: Hazardous Voltage:



## Safety Instructions

1. Please read and follow these instructions when connecting and using the system.
2. To avoid electrical shock, never touch the inside of the electrical box. Only a qualified technician should open the electrical box.
3. Never use the system if the power cord or float switch cable has been damaged. Do not allow anything to rest on the power cord or float switch cable, and keep the cords away from any place where people may trip over them.
4. When disconnecting from the electric socket hold the plug, not the cord.
5. If the processor does not function properly, especially if there is an unusual sound or smell coming from it, immediately unplug the processor. Call your authorized service representative.
6. Unplug the processor and RP pump from the AC outlet prior to any service.
7. Locate the RP Assembly as close as possible to an AC outlet.
8. Securely bolt processor to wall before operating.
9. Avoid cross-connections and install on cold water supply only.
10. Use approved Air-Gaps when connecting to drain lines.
11. Do not exceed system pressure rating and use water hammer arrestors when water hammer is evident.
12. Turn off Feed-Water supply before filter or membrane cartridge replacement.

## Getting To Know Your System

The OP350 Advanced Membrane Separation System is designed to purify feed water and remove dissolved minerals, and then add back a consistent amount of a balanced blend of TDS (Total Dissolved Solids), or mineral content, in the treated water, providing an Optimized Water to your equipment with the characteristics that you desire.

**Water Quality Indicator** - Operates momentarily, push purple button to turn on. Push "IN" button for the TDS of the water going into your equipment. Push "OUT" button for the TDS of the purified water from the membrane.

**120VAC Power Cord**  
- Plug in to standard wall outlet.

**Feed water Inlet** 3/8" Push-To-Connect - Connect to Water Supply Valve.

**Emergency Bypass Valve** - User can switch from Optimized Water to Untreated Water when needed.

**Reject Water Outlet** (behind filter) - 1/4" Push-to-Connect - Connect to drain per local regulations.

**Reject Flow Control Valve** (behind filter)

**2@ CTO-Q Pre-Filters**  
PN: 300-05830

**Buffer Tank** - Pre-charged air bladder - 20 psi

**Buffer Tank Valve**  
Normally open, shown closed at right. Used to shut off water supply to downstream equipment.

**Low Level Float Switch (Switch inside tank & control box attached to Buffer Tank bracket)** - Shuts off pump when tank is empty.

**High Level Float Switch Cable (on back side of tank)** - Connect to Processor "Tank Electrical Connection."

**Repressurization Assembly Outlet**  
- 1/2" Hose Barb - Connect to Pressurized Water Inlet on Processor

**Optimized Water to Storage Tank Inlet** - 3/8" Push-to-Connect - Connect to Optimized Water Outlet on Processor.

**Tank Inlet Divert Valve**  
- Normally in Down position. Turn handle to Up position to divert Optimized water to sample port.

**Operating Pressure Gauge**

**Optimized Water To Storage Tank**  
- 3/8" Push-To-Connect - Connect to Optimized Water Storage Tank Inlet

**Sample Port** - 3/8" Push-to-Connect - Used **ONLY** to flush pre filters, gather a water sample, measure production, or drain water from storage tank.

**Pressurized Optimized Water Outlet** - 1/2" gray hose - Connect to End User Equipment

**Tank Repressurization Return** - 1/2" gray hose - Connect to Repressurization Assembly Outlet

**MA-Q15 Mineral Addition Cartridge**

**AMS-QT Membrane Cartridge**

Membrane Reject Water Tubing Connection

**Repressurization Pump** 120VAC - Plug in to standard wall outlet.

**Absolute 0.2 micron Hydrophobic Air-Breather/Filter**

**Repressurization Pump** 120VAC - Plug in to standard wall outlet.

**Absolute 0.2 micron Hydrophobic Air-Breather/Filter**

**Optimized Water Storage Tank**  
- 50 gal. Atmospheric

**Optimized Water Storage Tank**  
- 16 gal. Atmospheric

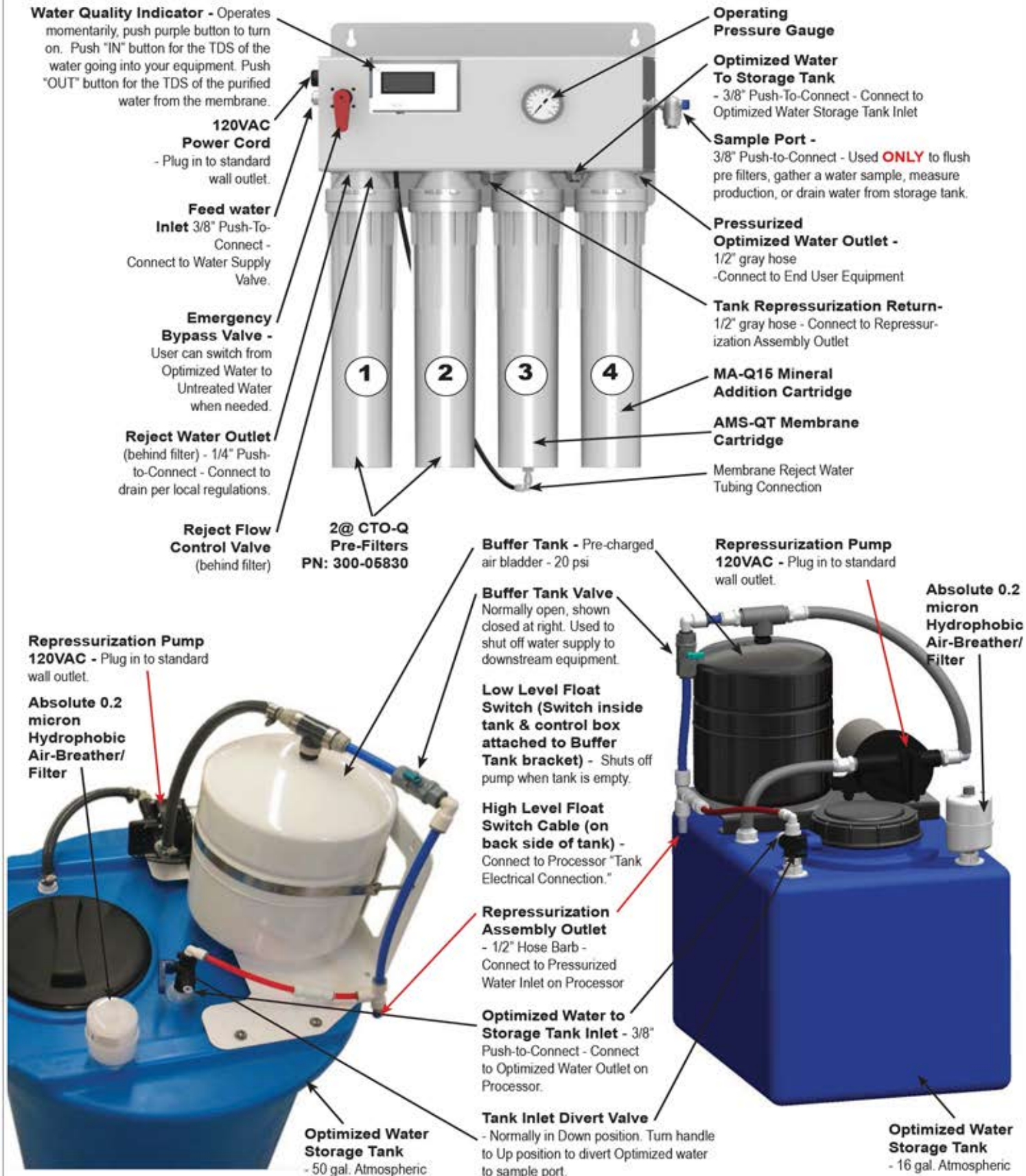

## Installation Requirements

This section and the next provide the water, electrical and space requirements for the OP350. **Pay special attention to the feed-water chemistry requirements.** Operating a system on water supplies outside of these parameters may lead to premature membrane failure. This product is for commercial use only and must be installed and maintained in accordance with manufacturer's guidelines and local regulatory plumbing and electrical codes.

### Operating parameters

Typical Membrane TDS* rejection:	97+%
Feed Temperature:	40 - 100° F (4 - 38° C)
Feed pressure:	50 - 80 psi (3.4 - 5.9 bar) at 1 gpm
Production** (at 77°F, 60 psi)	350 gals/day, 14.6 gals/hr, 0.24 gpm
Recovery:	up to 33%.

**IMPORTANT NOTE:** The nominal production rate is strictly dependent on feed water temperature and pressure. Reduced temperature or pressure will reduce production. For example: Operating pressure of 30 psi will cut production by 50%. 48°F feedwater will cut production by 50%.

### Location

The system should be installed indoors, in the proximity of the equipment (within 25 feet) and protected from the elements. Do not let the processor or storage tank freeze or be exposed to rain or direct sunlight.

### Additional Optional Post-treatment

Treated water stored in a tank may absorb organic compounds from the tank, which can affect water taste and odor. If product water is for consumption, an optional post-treatment filter, such as an OptiPure FX or QT carbon filter, should be installed after the tank. If used, it is best installed as close to the point of use as possible. Other specialized post-treatment is also available.

### Feed water connection

An adequate flow and pressure of water to the unit is essential for successful operation. Provide a dedicated 1/2" water line to the vicinity of the installation. Install a full-flow ball valve and pressure gauge with 1/2" female pipe thread (user supplied) for connection to installation hardware provided with the system. A 1/2"

\*TDS (total dissolved solids) create conductivity in water and are expressed in ppm or mg/l (parts per million or milligram per liter).

\*\*Nominal production @ 77°F (25°C) @ 500 ppm based on a 24 hr day. Actual production will vary based on variations in water temperature, pressure, and TDS.

male pipe thread x 3/8" push-to-connect adapter is included in the installation kit.

### Drain

A drain should be located within 5 feet of the location of the unit. Drain must allow a minimum flow of 2 gallons per minute. Compliance with most local plumbing codes requires installation of an approved air gap in the drain line. The drain connection should be accessible for system set-up and service.

### Electrical requirements

A power source with two outlets should be located within 5 feet of the location of the unit.

Processor	120V, 60Hz 6 Watts
RP Pump	120V 60Hz 2 Amps

### Feed-water chemistry

Feed TDS	Up to 1200 ppm
Feed pH	6 - 10
Hardness	28 grains or less
Free chlorine	<2 mg/l
Iron (Fe)	0.1 mg/l max.
Turbidity	<0.05 NTU
Manganese	0.05 mg/l max.
Hydrogen sulfide	0.0 mg/l

A water analysis must be conducted before installing the system, or the information requested above can be obtained from your local water utility. If your water analysis shows that any of these parameters are not within range, additional pretreatment and/or higher frequency of maintenance may be required. Contact your OptiPure distributor for assistance. The presence of silica or flocculants such as alum or cationic polymers in the feedwater may cause membrane fouling and may require special chemical pretreatment or periodic membrane cleaning. Please note that membrane failure due to fouling is not covered by the warranty.

### Storage Tank

The tank must be located within 10 feet of the water processor unit. The floor beneath the storage tank should be smooth, clean and free of sharp objects that could puncture the bottom of the tank. **Note: The tank is atmospheric, with a sub-micron, hydrophobic air breather filter.**

### Optimized Water Lines to Equipment

Tubing, piping and associated fittings connecting Optimized water lines to equipment should be food grade material that meets NSF Std 51 or 61 with a minimum pressure rating of 75 PSI. Optimized water may react with most metal piping imparting a bad taste. Plastic pipe or reinforced opaque beverage tubing are acceptable choices for Optimized water distribution. The larger inside diameter tubing or hose, the better to minimize pressure drop.

**Equipment Dimensions**

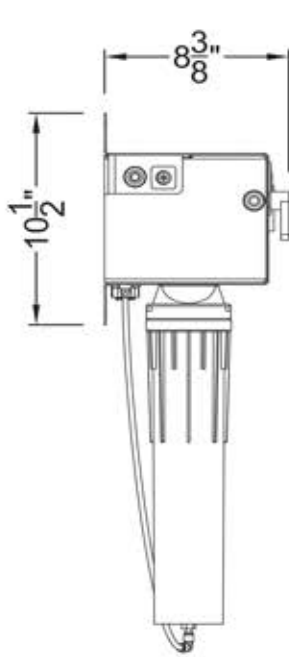

**Processor  
Left Side  
View**

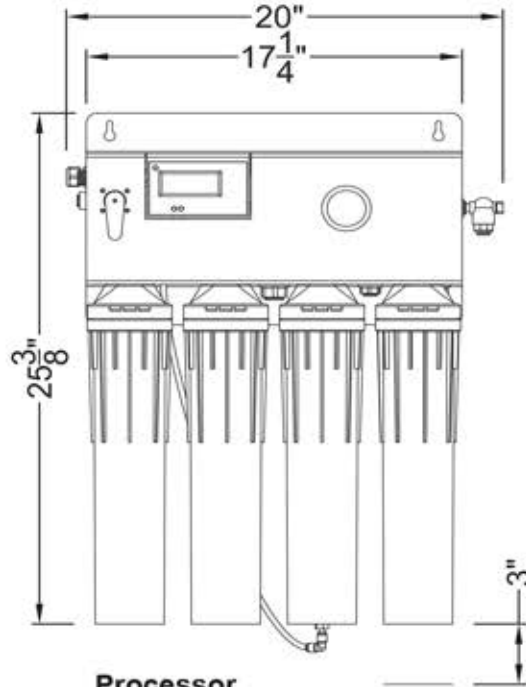

**Processor  
Front View**

Allow 3"  
to remove  
cartridges

**IMPORTANT - ALLOW A MINIMUM OF 24" IN FRONT OF THE PROCESSOR FOR MAINTENANCE AND SERVICE. DO NOT MOUNT SYSTEM ABOVE THE CEILING OR IN A LOCATION THAT IS NOT EASILY ACCESSIBLE. WHEN THE 50 GAL. TANK ASSEMBLY IS FULL OF OPTIMIZED WATER IT WILL WEIGH 450 LBS (THE 16 GAL. TANK, 140 LBS). ALWAYS LOCATE THE STORAGE TANK WHERE IT CAN BE ACCESSED (OR IS ACCESSIBLE) DURING SERVICE.**

**Tank Assembly (50 gal.)**

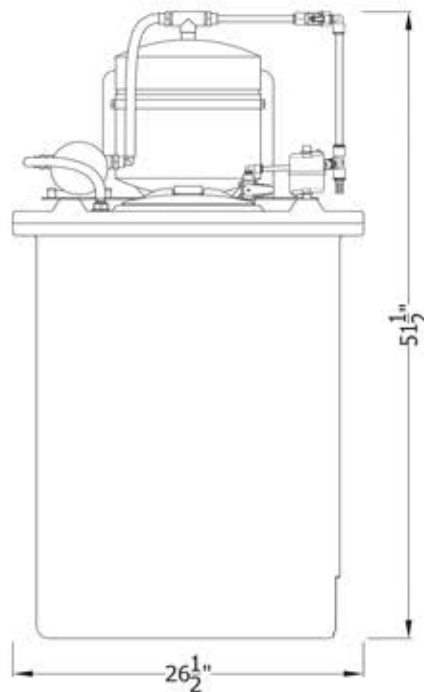

**Tank Assembly (16 gal.)**

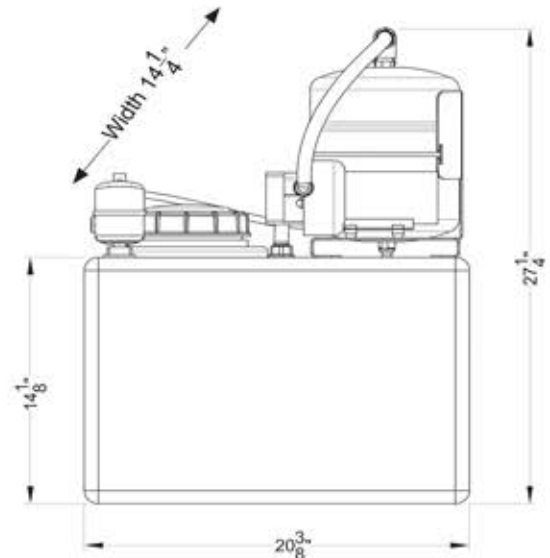

**Right Side View**

**Optional Atmospheric Storage Tank**



**175 Gallon Tank,  
31" dia. x 68" tall**

## Typical Installation with 50 Gal. Atmospheric Tank

**Important: Plumbing should be performed by a qualified plumber in accordance with local codes.**

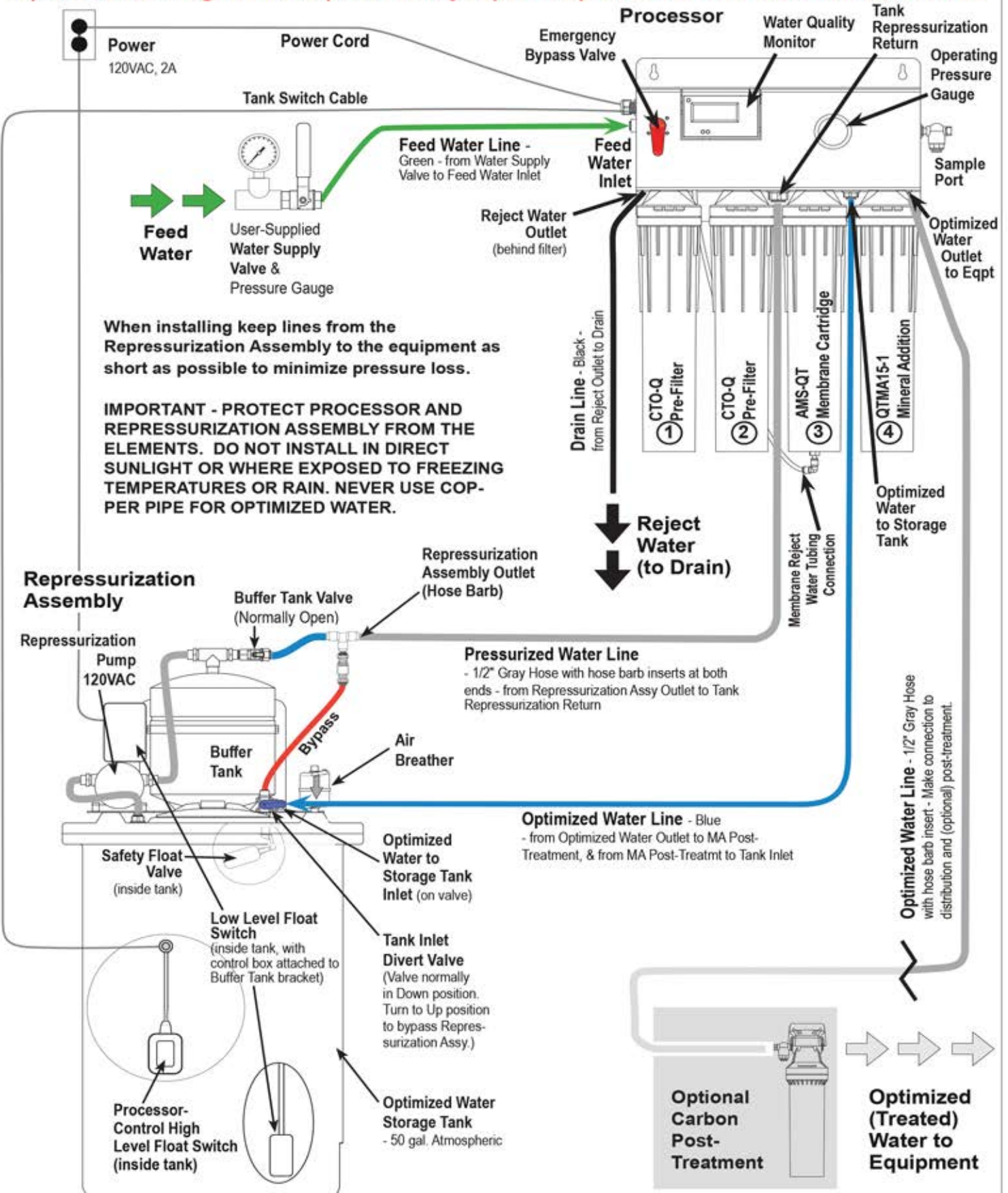

## Installation with 16 Gal. Storage Tank

Refer also to "Typical Installation" Diagram on previous page.

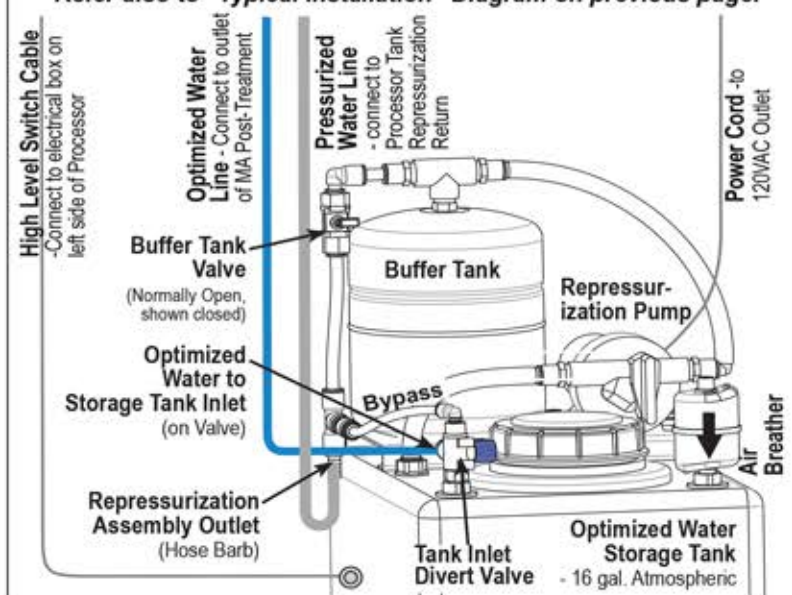

screws. BE SURE TO ALLOW 3" BELOW THE CARTRIDGES TO ALLOW FOR REMOVAL. Screw the four bolts or screws in place, leaving approximately 1/4" clearance between the bottom of each bolt head and the wall. Position the system over the mounting bolts, and let the bracket slip down into the keyholes.

Mount the Optional Post-Treatment unit to the wall near the OP350 Processor. This unit will be plumbed-in between the Processor and the Equipment. Tighten all screws.

## System Installation

**Note:** Do not install the cartridges in the processor until completing this section. Do not plug in the power cord from the RP pump until completing the following section, "System Start-Up".

Refer to "Typical Installation" diagram on page 6 and "How to Use Our Quick-Connect Fittings" on page 20 when making the following connections.

A feed water ball valve and pressure gauge (user supplied) should be installed to provide water to the system FEED WATER INLET with the green tubing (supplied). Hose, tubing and fittings for making connections between the processor, storage tank and drain are supplied in the installation kit.

1. Remove the tank lid. Inside the tank, the float valve may be secured for shipping. Remove any wrapping on the float to allow it to hang and move freely.
2. DRAIN: Connect the 1/4" black tubing from the installation kit to the REJECT WATER OUTLET on the processor. Run the line to an appropriate drain. Observe local plumbing codes and supply an appropriate air gap. (Any fittings for connecting to the drain will need to be supplied by the customer.) Fix tubing in place at the drain.
3. FEED WATER: Apply 3 'wraps' of Teflon tape to the 1/2" MPT x 3/8" push-connect fitting (supplied). Screw the fitting into the Feed Water Supply Ball Valve and tighten (DO NOT OVERTIGHTEN). Connect one end of the 3/8" GREEN TUBING to this fitting. Connect the other end of the tubing to the FEED WATER INLET located on the left side of the Processor. Cut the tubing to the required length if necessary.

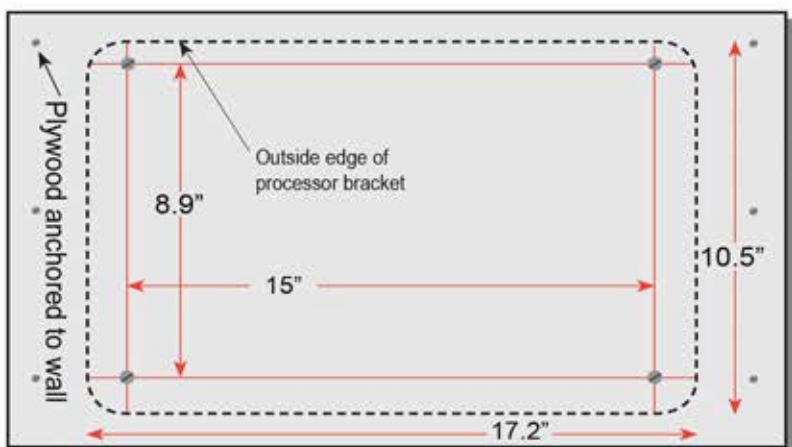

## Wall Mounting

The processor should always be mounted where it is well-supported, either using anchors in a cement wall, or using the support of studs in a wall-board wall. **Never mount it directly to sheet-rock alone.** Instead, mount it on a sheet of plywood which is anchored to the wall studs, as shown above.

Four user-supplied bolts or screws with a head diameter of approximately 1/2" (which will fit into the keyholes in the system bracket, but will not slip out when tightened) should be used to hang the system.

This will allow the unit to be lifted off the bolts, if necessary for maintenance, without removing all the bolts from the wall. Hold the processor in place (without the cartridges) to mark the locations for the

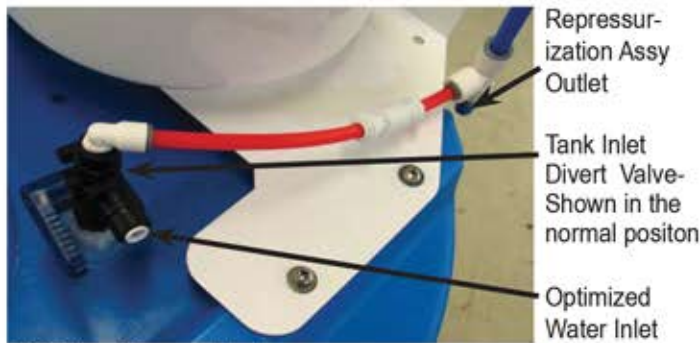

50 Gallon Storage Tank

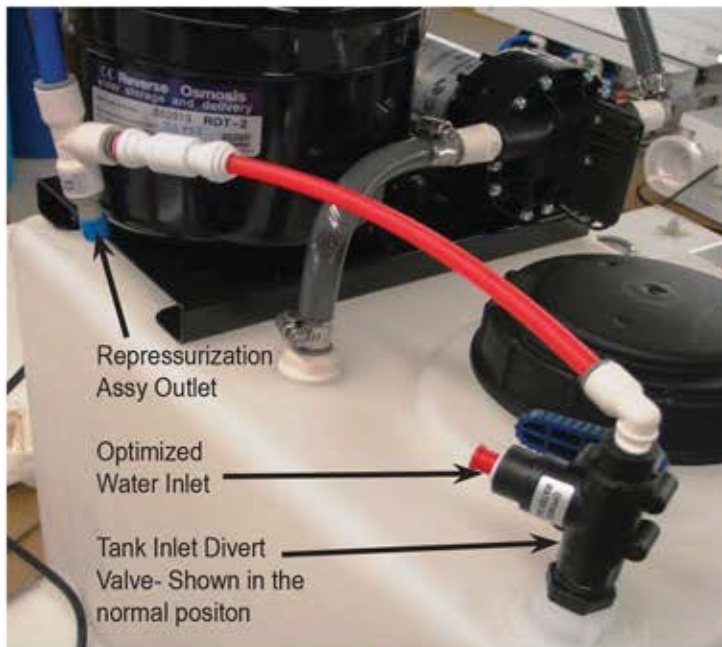

16 Gallon Storage Tank

**NOTE:** When cutting the tubing use a sharp tubing cutter or blade and make a clean, straight cut before inserting into a push-connect fitting. When routing tubing, do not make sharp bends or crimp the tubing.

4. **PROCESSOR TO STORAGE TANK:** Connect a piece of the 3/8" blue tubing to the OPTIMIZED WATER TO STORAGE TANK fitting on the processing unit. Connect the other end of this tubing to the OPTIMIZED WATER TO STORAGE TANK INLET on the storage tank INLET DIVERT VALVE.
5. **REPRESSURIZATION ASSEMBLY TO PROCESSOR:** Using two of the 1/2" hose barb inserts (supplied), a piece of 1/2" gray hose, and two hose clamps, connect hose from the REPRESSURIZATION ASSEMBLY OUTLET on the Repressurization Assembly to the

**TANK REPRESSURIZATION RETURN** on the Processor. The ridged end of a hose barb insert goes into each end of the hose with a hose clamp tightened onto it. The smooth ends of the hose barb inserts go into the push-to-connect fittings on the Processor and Repressurization Assembly.

6. Route the cable coming from the tank switch to the electrical box on the processor. Connect the AMP connector to the TANK ELECTRICAL CONNECTION located on the grey electrical box.
7. **OPTIMIZED WATER TO EQUIPMENT:** Connect a piece of 1/2" ID gray hose to the OPTIMIZED WATER OUTLET on the processor with a 1/2" hose barb insert and clamp (supplied). At a later time, the other end of this line will be connected to the distribution line that will deliver Optimized Water to the equipment, but **for now leave the line loose and route the loose end of the gray hose into a drain or bucket. (Make certain the hose length will reach the storage tank; this will be required for the Start-Up procedure.)** Prepare any necessary plumbing to make the connection between the 1/2" hose and the distribution line, which will be completed in "Connect to Equipment".

**NOTE:** If additional Post Filtration is used, it will be installed between the Optimized Water Outlet and the designated equipment.

## Install QT Cartridges

**NOTE:** Before installing the QT Cartridges make sure to remove the plugs in the QT heads.

1. Insert the CTO-Q cartridges into QT heads 1 & 2 (starting from the left or inlet side of the processor) and turn to align arrows.
2. Insert the AMS-QT membrane cartridge into the QT head #3 and turn to align arrows.
3. Connect the Push-to-Connect elbow (remove plug in elbow) on the end of the black Reject tubing to the stem connector on the bottom of the AMS-QT cartridge.
4. Insert the MA-Q15 cartridge into the QT head #4 and turn to align arrows.



## Optional RP Assembly Location

The Repressurization Pump and Buffer Tank assembly is on a stand that can be remote from the storage tank. To do so, order the applicable remote RP kit and follow the instructions with the kit. They involve removing the four bolts on the feet of the bracket, adding rubber feet, and lengthening the gray hose from the tank to the pump, the red bypass tubing from the Tank Inlet Divert Valve to the Buffer Tank, and the gray cable from Low Level Float Switch to Control Box. Use the following Kit Part number:

16Gal Tank - 164-89116

50Gal Tank - 164-89150

## System Start-Up

Refer to illustrations "Typical Installation" (page 6) and "High Level Switch Testing" (page 20).

**IMPORTANT:** Before proceeding, position the Processor EMERGENCY BYPASS VALVE in the "SERVICE" position, assure that the BUFFER TANK VALVE is open, and position the TANK INLET DIVERT VALVE in the down position (Blue Valve Handle pointing sideways).

1. Slowly open the user-supplied WATER SUPPLY VALVE. Plug the processor power cord into a 120VAC outlet. Allow the filter housings to fill, and water will begin to flow from the end of the 1/4" black tubing routed to the drain. After some time, water will begin to flow into the tank. Allow several minutes to flush the system until water flows smoothly into the tank and also from the drain line. Check all of the plumbing connections and correct any leaks if necessary.
2. Test the high level float switch. With the tank lid removed and the system running, raise and tilt the high level float (in the tank). As you raise the float upward, the ball inside the float will roll from one end of the float to the other, activating the switch.
  - With the float in the upright position, the water processor should shut off the water flow.
  - Lower the float allowing the ball to drop back down. The water should begin flowing again.
3. The 16 Gal Storage Tank must be filled – or the 50 Gal Storage Tank filled approximately 1/3 of the way – to start-up and purge the Repressurization

Assembly. You can quickly fill the storage tank to the appropriate level using the "System Bypass" on the processor. To do this:

- Route the 1/2" gray hose from the processor OPTIMIZED WATER OUTLET TO EQUIPMENT directly into the storage tank lid opening.

**NOTE:** Before performing the next step, be certain to hold onto the gray hose.

- Turn the EMERGENCY BYPASS VALVE on the processor to the "BYPASS" position. This will allow feed water to bypass the processor and quickly fill the storage tank.
- **When the tank fills to approximately 14 gallons (or 1/3 full with the 50 gal. tank), return the PROCESSOR EMERGENCY BYPASS VALVE to the "SERVICE" position.**

**NOTE:** Before performing the next step, be certain to hold onto the gray hose.

4. Plug the power cord from the RP pump into the outlet. Water should begin to flow rapidly from the storage tank, through the RP assembly, and back into the storage tank through the gray hose. Allow the pump to recirculate the water for several minutes until all the air is purged from the Repressurization Assembly. As the air is purged, the pump will begin to run more smoothly and the water flowing from the gray hose will become steady.
5. Unplug the RP Pump cord.

## Connect to Equipment

Refer to the illustration "Typical Installation" on page 6.

1. Remove the 1/2" gray hose that was routed into the storage tank (from the Optimized Water Outlet at the Processor) and make the connection to the distribution line that delivers Optimized Water to post-treatment (if used) and designated equipment.
2. Ensure that any valves or solenoid valves on the connected equipment are closed. Plug the RP Pump back in. The pump will run and fill the Buffer Tank until the pressure in the Buffer Tank reaches 70 psi, and then the RP Pump will shut off.
3. Open downstream valves at the equipment to allow water to flow and air to purge through the

post-treatment (if used) and from the distribution lines. When purging distribution lines the pump may shut off if the water level in the storage tank drops near the bottom of the tank. (Add more water to the tank if necessary.) Once distribution lines are flushed and all air is purged, close the equipment valves. When there is no demand for water the buffer tank will fill and the pump will shut off automatically.

4. Before proceeding, follow these steps to empty the storage tank of untreated feed water:
  - Connect a piece of 3/8" blue tubing into the push-to-connect fitting of the SAMPLE PORT VALVE on the right side of the processor, and route the other end of the tubing into a drain or bucket.
  - Open the Sample Port Valve to drain water from the storage tank. When the pump shuts off due to a low water level, close the Sample Port Valve.
5. Replace and tighten the lid onto the storage tank.

## Complete the Installation

### Transition to Owner/Operator

The final step is to meet with the owner/operator, familiarize them with the system and complete the post installation check list.

The system is now in "normal operating" mode and the storage tank will fill with Optimized Water from the processor. Complete the "Check List" to "Confirm Normal Operation and System Settings" (page 4 of the "Quick Installation Guide") with the Owner/Operator.

Allow the tank to fill before beginning operation of the connected equipment.

## Reading the TDS

1. To read the TDS, the 16 Gal. tank must be allowed to fill half way – or the 50 Gal. must be filled about 1/4 of the way – with optimized water.
2. TDS must be read while there is some demand for water flow from the RP Assembly. Open a valve downstream at the equipment, or open the Sample Port Valve on the processor (with tubing routed to a drain or bucket) to allow flow.
3. Push the purple "POWER" button on the Water Quality Monitor located on the upper left corner. It will immediately display the "IN" or Optimized Water TDS (Total Dissolved Solids) in PPM (parts per million). Document this number as the Optimized Water TDS.
4. Within 30 seconds, push the "OUT" button to display the Membrane Permeate TDS and record this number as the Permeate TDS.

## What are all those parts and what do they do?

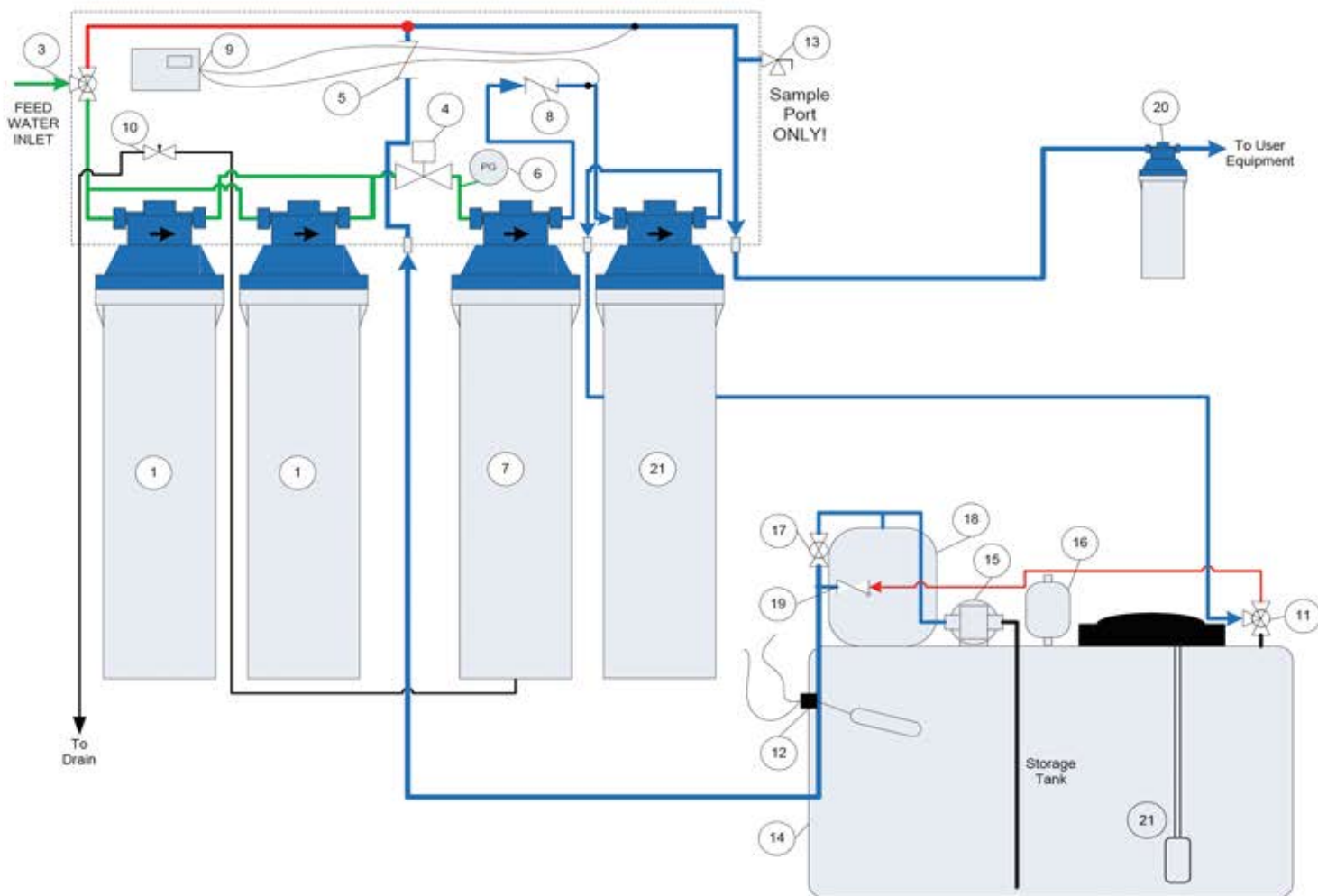

### This section will give you an overview of how the system works.

- Incoming water is filtered by the prefilters (1), which remove sediment, chlorine and organics.
- When the Emergency Bypass Valve (3) is in the normal SERVICE mode, water flows through the Processor. When the Bypass Valve (3) is in System Bypass mode, the water is diverted directly out to the equipment, bypassing both the Processor and the Repressurization Assembly.
- When water in the storage tank (14) is at a low storage level, the high level float switch (12) drops, causing the switch to close, causing the Solenoid Valve (4) in the Processor to open, allowing feed water to flow through to the AMS-QT membrane (7).
- The membrane feed water pressure is indicated by the pressure gauge (6).
- The water flows to the inlet of the membrane (7). The water is split by the membrane into a pure water stream and a reject water stream. The reject water flows to the Reject Flow Control (10) and then on to drain.
- The pure water stream continues through the Permeate Check Valve (8), then through the Mineral Addition cartridge (21), where minerals are added back in to the Optimized Water stream. It then flows to the tank through the Tank Inlet Divert Valve (11) on top of the Storage Tank (14). Air in the tank is displaced by the incoming water and vented out of the Sub-Micron Air Breather (16).
- When the tank completely fills, the high level float switch rises, causing the switch to open, causing the Solenoid Valve (4) to close, stopping the flow through the Processor.
- When the "IN" button is actuated on the Water Quality Monitor (9), it measures the TDS of the

Optimized Water in the Optimized Water Line coming from the storage tank. (However, if the Emergency Bypass Valve (3) is in the BYPASS position and the "IN" button is actuated, the TDS of the feed water will be displayed.) When the "OUT" button is actuated, the Water Quality Monitor (9) indicates the TDS of the Permeate water exiting the Membrane (7). The Water Quality Monitor (9) is battery powered with two AA batteries. It will automatically shut-off after 30 seconds.

- As long as the Low Level Float Switch (21) detects a minimum level of water in the tank, the Repressurization Pump (15) is enabled to draw from the Atmospheric Storage Tank (14) and dispense Optimized water, by way of the Buffer Tank (18), to the Processor, through the One-Way Check Valve (5), and out to the equipment. When the pressure in the Buffer Tank drops, the Pump runs to repressurize the Buffer Tank, and when the pressure reaches 70 psi, the Pump shuts off.
- The Optional Post-Treatment Filter (20) is designed to provide additional treatment based upon specific application requirements. For beverage applications an activated carbon filter is recommended.
- As Optimized Water is dispensed from the storage tank by the Repressurization Pump (15), air is replaced in the tank through the Sub-Micron (0.2 micron) Air Breather (16).
- If the Repressurization Pump (15) fails, water flow and can be restored to the equipment by turning the Emergency Bypass Valve (3) to the "SYSTEM BYPASS" position. This allows tap water to bypass the processor and RP assembly.
- A Sample Port (13) provides the ability to measure membrane production by closing the Buffer Tank Valve (17) and turning the Tank Inlet Divert Valve (11) to the bypass or UP position. This diverts the permeate (pure water produced by membrane) through the Bypass Check Valve (19) and back to the processor where opening the Sample Port (13) will allow you to directly measure the permeate flow rate.
- Additionally the Sample Port (13) provides the ability to drain water from the Storage Tank (14) by closing the user-supplied Water Supply Valve, opening the Buffer Tank Valve (17) and opening the Sample Port (13).

## Repressurization Pump

The Repressurization Pump Assembly that comes standard with the OP350 System includes a diaphragm pump controlled by an internal Pressure Switch, and a Buffer Tank between the Pump and the downstream equipment maintains downstream pressure. Water demand for downstream equipment is directly supplied from the Buffer Tank, and demand can go on and off as necessary. The RP Pump is not directly affected by downstream demand, and downstream equipment is also not affected by the automatic starting or stopping of the RP Pump. When the pressure drops sufficiently in the Buffer Tank, the pump starts automatically and repressurizes the Buffer Tank. The operating pressure for the Buffer Tank is preset (to 70 psi) and is NOT field adjustable.

The pump also incorporates check valves to keep the Buffer Tank and downstream line pressurized. The pump is equipped with auto-reset, thermal overload protection and is designed for intermittent duty.

**If the pump runs erratically, allow the pump to run to open drain with valve fully open to purge air from the pump head. Disconnect the power and reconnect several times to facilitate air purging.**

The pump will prime only if all the pressure is relieved from the outlet port. The pump is self-priming up to 11 ft. The pump can run dry but will overheat and the pump overload will shut the pump off.

## Storage Tank Level Controls

(See also the Electrical Schematic at the end of this manual.) For system control, there are independent High and Low Water Level Float Switches in the Storage Tank. When the Storage Tank becomes full, the High Level Float Switch shuts off the Processor, preventing flow to the Tank.

If the tank is empty, the Low Level Float Switch automatically shuts off the RP Pump.

As long as the power cord from the Tank/RP unit is plugged in, and there is a minimal amount of water in the Storage Tank, the green light is illuminated on the Control Box (attached to the Buffer Tank bracket), indicating that power is supplied to the RP Pump. This light means the RP unit is operational, even though the RP Pump may be automatically turned off when the Buffer Tank is pressurized and operation of the Pump is not needed.



Low Level Float Switch Indicator light

**OP350 Processor Components**

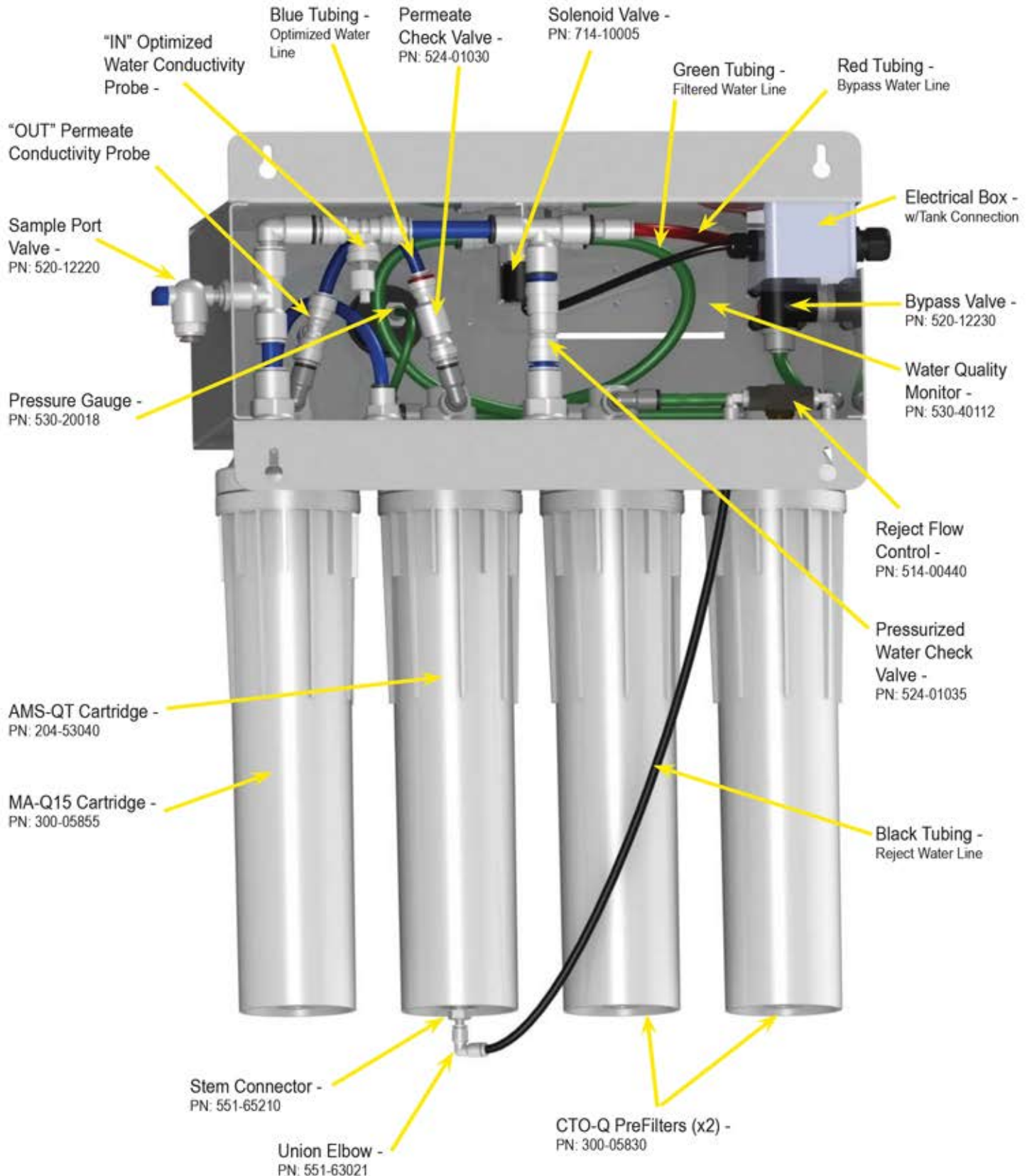

## Tank/RP Components

50 Gallon Storage Tank Shown.

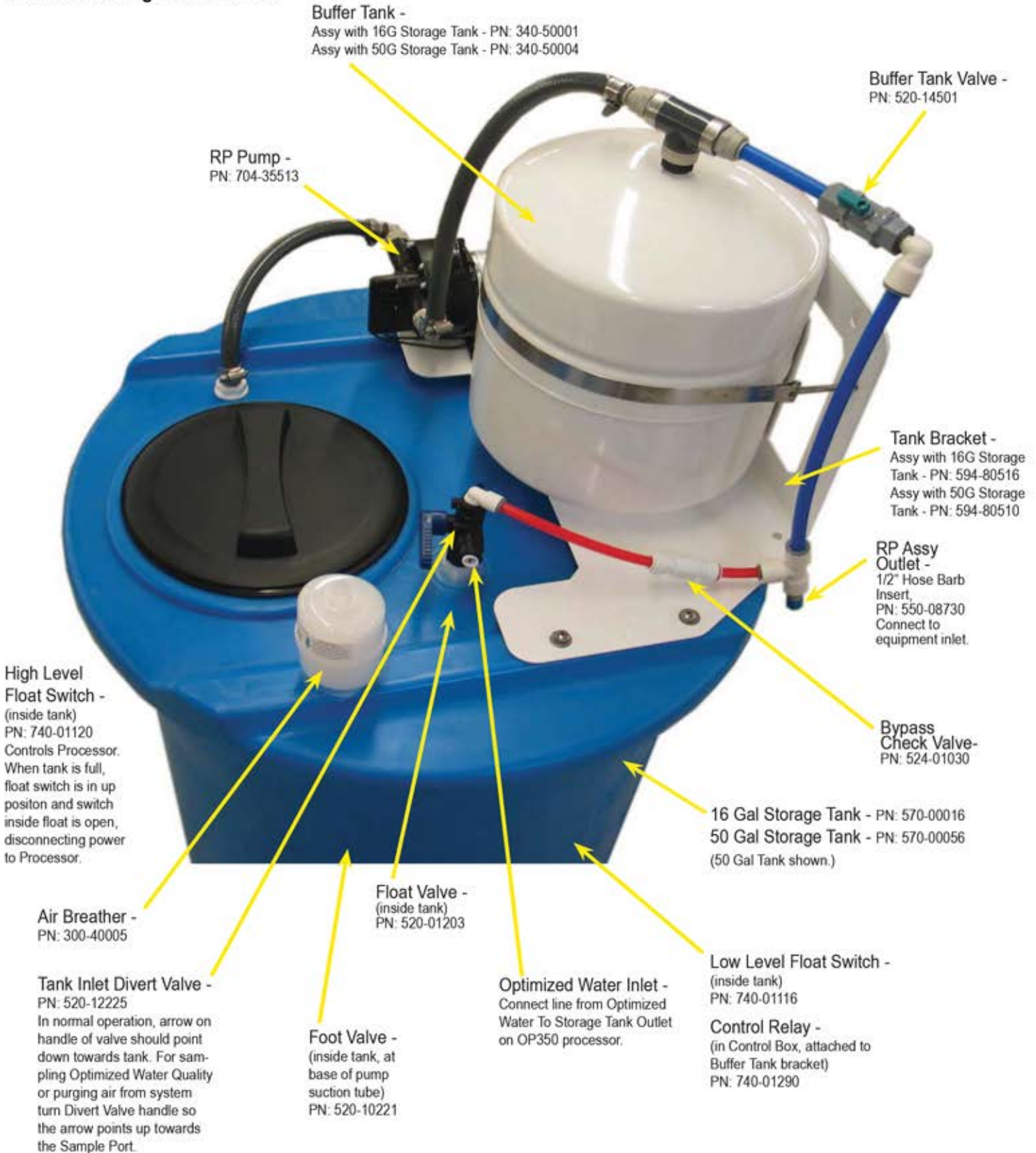

## Product/Reject Flow Rate Adjustments

### Introduction

The AMS-QT Reverse Osmosis membrane uses pressure to allow pure water molecules to filter through its semipermeable membrane separating pure water from dissolved solids (salts) and other contaminants. In essence the membrane splits feed water into two separate streams. One stream is the water produced for use (product or pure water), and the other contains the salts and contaminants filtered out by the membrane (reject) carried away to the drain. The OptiPure OP350 is designed to produce water at a 30% recovery rate which means it uses water at a ratio two gallons of reject water for each gallon of pure water produced. This is a **Product/Reject Ratio of 1/2**.

### Each system is adjusted at the factory for the proper operating parameters.

In most cases the factory setting should not be changed. However, due to certain conditions an adjustment may produce better operating efficiency and membrane performance. Conditions that can influence the best Product/Reject Flow Rate Ratio include feed water quality (TDS level, Turbidity and specific contaminants such as iron and silica) along with water temperature and water pressure. The determination of whether to make a Product/Reject Flow Rate adjustment is complex. An understanding

of your water chemistry and operating conditions is necessary in order to safely deviate from the factory setting. It is strongly recommended that you contact your OptiPure dealer or the factory for assistance before changing the factory setting.

### Reject Flow Rate Adjustment

The parameter that can be adjusted is the **Reject Flow Rate**. This is the amount of water used to carry away the impurities rejected by the membrane. It is critical that both the Product Flow Rate and the Reject Flow Rate are measured to confirm the desired Product/Reject Ratio has been achieved. The higher the ratio of product to reject flow rate, the shorter the life of the membrane will be. **The system should never be operated with a product flow rate higher than the reject flow rate, as this will cause premature fouling and shorten membrane life.**

To adjust the reject flow rate, locate the reject flow control valve. Loosen the lock-nut (at the base of the valve stem) just slightly.

To increase the reject flow rate, use a slot screw driver to turn the valve stem counterclockwise. To reduce the reject flow rate, turn it clockwise. A minor adjustment makes a big difference in the flow rate so begin with



Reject Flow Control

**! NEVER CLOSE THIS VALVE!** Inadequate reject flow will result in membrane failure.

## Operating Parameters

Ratio Product/ Reject	Oper Temp (°F)	PRODUCT FLOW RATE				REJECT FLOW RATE			
		(gal/day)	(gpm)	(L/day)	(lpm)	(gal/day)	(gpm)	(L/day)	(lpm)
1/2	50	185	0.13	701	0.49				
1/2	64	271	0.19	1027	0.71				
1/2	77	<b>350</b>	<b>0.24</b>	<b>1325</b>	<b>0.92</b>	<b>700</b>	<b>0.48</b>	<b>2650</b>	<b>1.84</b>
1/2	84	380	0.26	1440	1.00				

- The flow rates above are for 60 psi feed pressure.
- To convert gallons per minute (gpm) to ounces per minute, multiply gpm by 128.
- To convert gallons per minute (gpm) to milliliters per minute, multiply gpm by 3785.

small (1/2 turn) adjustments. After making an adjustment, measure the reject and product water flow rates. Make additional adjustments until the desired Product/Reject Ratio is achieved, then tighten the locknut.

Use the "Operating Parameters" table above as a guideline for safe operating flow rates and ratios. This table provides an indication as to how Feed Water temperature affects the Product Water output of the system.

### Measuring Product Flow Rate

Connect a piece of 3/8" tubing to the Sample Port on the right side of the Processor and route it to a bucket or drain. If the tank is full, turn the Sample Port valve to the sample position and allow about 20 gallons to drain out of the storage tank, then close the Sample Port valve. Close the Buffer Tank Valve and turn the Tank Inlet Divert Valve to the divert position (Up). Open the Sample Port valve. While the system is operating in normal mode (Emergency Bypass Valve in Service position), use a graduated cylinder or other measuring vessel to collect and measure the amount of water that is produced (from the tubing connected to the Sample Port) in 60 seconds. To convert ounces per minute to gallons per minute, divide ounces/min by 128. To convert milliliters per minute to gallons per minute, divide ml/min by 3785. Multiply gpm times 1440 to get

gallons per day production.

When finished, close the Sample Port valve, turn the Tank Inlet Divert Valve to the Down position, and open the Buffer Tank Valve.

### Measuring Reject Flow Rate

Access the Reject Drain Line and perform the same procedure described in "measuring product flow rate."

### When To Adjust Reject Flow Rate

The factory sets the Product/Reject Ratio to 1:2 based on 60 psi Operating Pressure and 77°F which is typically 919 ml per minute +/- 15%. The AMS-QT membranes are nominally rated to produce 350 gpd at 77°F at 60 psi Operating Pressure +/- 15%.

**The AMS-QT membrane is rated for a target daily output of 350 gallons per day of Product Water when the feed water temperature is 77°F and the operating pressure is 60 psi. Do not exceed the rated output of 350 gpd/14.58 gph/0.243 gpm (1,325 liters per day/55.125 liters per hour/919 milliliters per minute). Always keep in mind that feed water temperature and pressure will affect the Product Water output. Depending on feed water pressure and temperature it may not be possible to achieve the rated production of 350 gpd.**



## Routine Maintenance: Filter Change Procedure

The only routine maintenance required on the system is periodic replacement of the carbon/sediment pre-filters and the mineral addition cartridge. The CTO-Q cartridges should be changed every 3-6 months depending on water usage. In areas with high levels of sediment and other contaminants the CTO-Q cartridges may require more frequent changes.

### Pre-Filter & Mineral Addition Cartridge Change Procedure

1. Either close the Water Supply Valve (shutting off all water flow), or put the Emergency Bypass Valve (on the Processor) in the System Bypass position (allowing untreated water to continue to flow to the equipment).
2. Wait a moment for system pressure to drain off.
3. Once the system pressure has been relieved, remove the necessary cartridges — either the first two (CTO-Q) cartridges or the fourth (MA-Q15) cartridge — by turning a quarter-turn to the left and pulling down on the cartridge.
4. Install the new cartridges into the QT heads by aligning the notches and pushing up, then turn a quarter-turn to the right.
5. Install a piece of 3/8" tubing in the Processor Sample Port valve, open the Sample Port, and direct to a bucket or drain.
6. Turn the Tank Inlet Divert Valve to the Bypass Mode (Handle Pointing UP).
7. Open the Water Supply Valve and put the Emergency Bypass Valve in the "SERVICE" position, allowing water to run into the new cartridges and purge air through the system and out the Sample/Flush Port to drain.
8. Once the air has been purged and filters flushed, close the Sample Port valve and return the Tank Inlet Divert Valve to the Normal position (handle horizontal or down).
9. Check for leaks.

### Optional Post-Treatment Cartridge Change Procedure

1. Close the ball valve at the inlet to the Post-Treatment assembly.
2. Remove the existing cartridge and discard.
3. Install the new cartridge.
4. Open the ball valve.



## Routine Maintenance: AMS-QT Change Procedure

The AMS-QT membrane is a high-efficiency, low-fouling reverse osmosis membrane that will provide product water with 95+% rejection of the Feed Water. The life of the membrane will vary depending on Feed Water quality, usage, and Pre-Filter maintenance. Typical membrane life is 12 to 18 months, but with routine scheduled Pre-Filter replacement, and no adverse Feed Water conditions, the AMS-QT membrane may last 2-5 years.

### AMS-QT Replacement

1. Either close the Water Supply Valve (shutting off all water flow), or put the Emergency Bypass Valve (on the Processor) in the System Bypass position (allowing untreated water to continue to flow to the equipment).
2. Place a bucket or other similar catch basin under the AMS-QT. Remove the black reject line from the push-to-connect elbow on the bottom of the membrane. (Refer to "Push-to-Connect Fittings" on page 16.) Allow the membrane and reject line to drain into the bucket.
3. Remove the AMS-QT cartridge from the head by turning the cartridge a quarter-turn to the left and pulling down on the cartridge.
4. With a wrench, remove the push-to-connect elbow and stem adapter attached to the bottom of the

AMS-QT cartridge. Remove the residual Teflon tape from the male 1/8" threads on the stem adapter.

5. Wrap the 1/8" male thread on the stem adapter with 2 wraps of Teflon tape and re-install in the bottom of the new AMS-QT cartridge.
6. Align the taps on the AMS-QT cartridge with the QT head and insert into the head and turn a quarter-turn to the right.
7. Insert the black reject line into the push-to-connect elbow on the bottom of the AMS-QT cartridge.
8. Install a piece of 3/8" tubing in the Processor Sample Port valve, open the Sample Port, and direct to a bucket or drain. Turn the Tank Inlet Divert Valve to the Bypass or UP position. Open the Water Supply Valve and put the Emergency Bypass Valve in the "SERVICE" position. Allow water to flush through the membrane, displacing air and preservative, to flow out the Sample/Flush port to drain for 5-10 minutes.
9. Actuate the Water Quality Monitor and check the "OUT" or Permeate Water TDS.
10. After the AMS-QT cartridge is purged of air, close the Sample Port.
11. Check for leaks.

## Trouble-Shooting

Problem	Possible Cause	Resolution
Running out of water.	Operating Pressure reduced Very cold Feed Water temperature  Low Feed Water Pressure Demand exceeds system capacity Tank Float Switch Open	Pre-Filters need to be replaced Raise water temp to increase production or determine if higher capacity system is required Install optional Feed Water Pressure Booster Pump Determine if the demand is unusual or consistent or resize system Remove Storage Tank lid and actuate Float Switch up and down
Poor water quality.	Membrane failure	Replace AMS-QT membrane
Low Optimized Water TDS	Expended Mineral Addition Cartridge	Replace MA-Q15 Mineral Addition Cartridge
Short AMS-QT membrane life.	Product/Reject Ratio mis-adjusted Poor Feed Water quality, presence of iron, silica or non-calcium carbonate hardness	Measure and adjust the Reject Flow Rate per Page 16, 17 Determine Feed Water quality by obtaining a water quality report from city water supply utility or contact your OptiPure dealer
Short Pre-Filter life	Heavy sediment loading	Add FXAF01-12 or -12B for added Pre-Filter protection
Processor Does Not Shut Off or Turn On	Tank Level Float Switch or Solenoid Valve not functioning	Remove Storage Tank lid and actuate Float Switch up and down. Replace Tank Level Float Switch or Solenoid Valve
Water Quality Monitor will not turn on	Dead batteries	Replace batteries by sliding Water Quality Monitor up and removing the six screws on the back cover. Remove cover to access batteries.
RP Pump runs intermittently or rough.	Air trapped in pump head. Downstream water leak.	Unplug pump and open downstream valve to empty Buffer Tank. Repair or eliminate downstream water leak.
RP Pump cycles on-off frequently	Low air pre-charge in Buffer Tank	Empty Buffer Tank and re-charge air pressure to 20 psi.

### Electrical Schematic, Low Level Float Switch/RP Pump Circuit

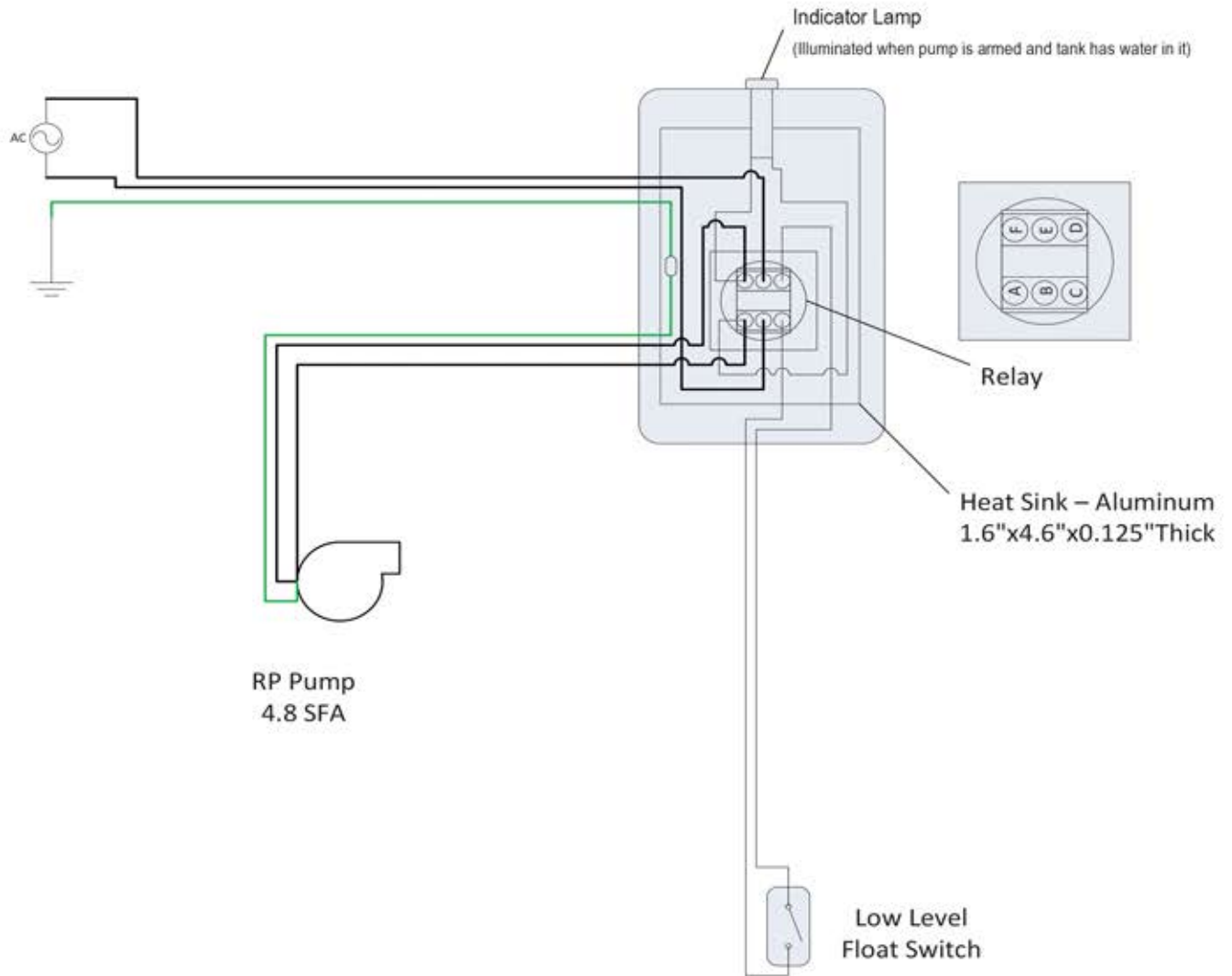

## How to Use Our Push-to-Connect Fittings

### Fitting Overview

Fitting Body

Collet/Gripper  
(Dark Gray)

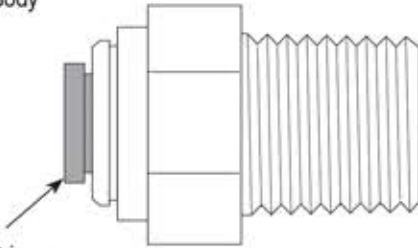

### Tubing Preparation

The outside of the tubing must be free of knicks and gouges.



Cut tubing with a plastic tubing cutter or a razor knife. Make a clean, square cut.

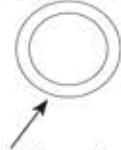

After cutting, make sure the end of the tube is round. Correct any out of roundness that may have occurred in cutting the tubing.

### To Attach Tubing:

To ease insertion, moisten end of tubing with fresh water or 3% hydrogen peroxide solution.

Push tubing straight in.

Cutaway view of fitting and tubing

1

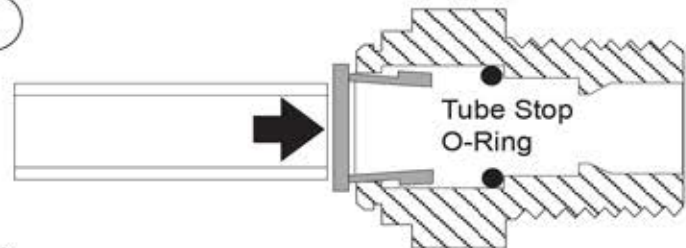

2

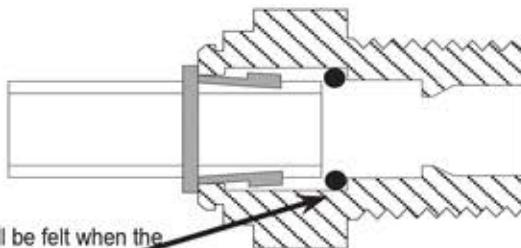

Resistance will be felt when the tubing meets the O ring.

3

Keep pushing until the resistance is overcome and the tubing rests against the stop.

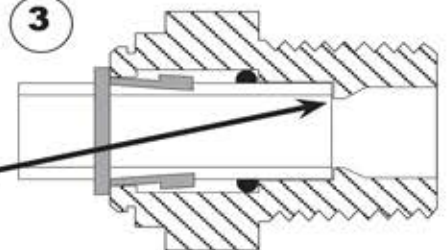

### To Remove Tubing:

Press collet in to release grippers. While holding the collet in, pull out on the tubing.

It may be necessary to use a partially open crescent wrench or similar device to hold both sides of the collet in while pulling the tubing out.

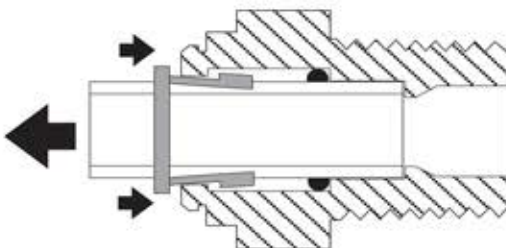

### High Level Switch Testing

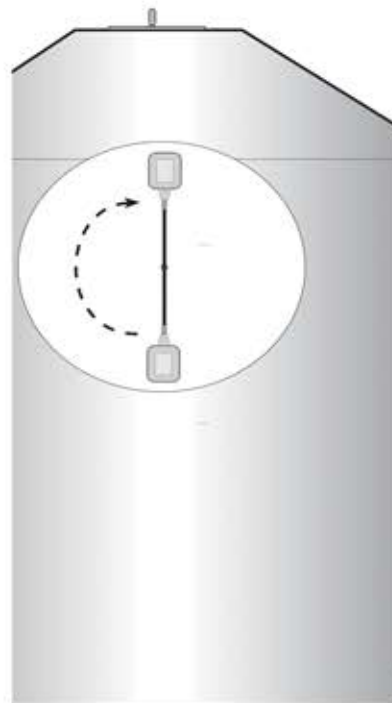

Switch Test:  
Float UP,  
Processor OFF

Float DOWN,  
Processor ON