



# Installation and Operation Guide

## Coldrink Series Filter System

### SELECTING A MOUNTING LOCATION

- Give consideration to the weight of the unit when operating (filled with water). Operating weights of the Coldrink Systems are:
  - System 1 - 24 lbs. (10.8 kg.)
  - System 2 - 35 lbs. (15.8 kg)
  - System 3 - 45 lbs. (20.2 kg)
- The location should allow for:
  - Minimum clearance of 2-1/2" under the cartridge(s) so it can be lowered for removal and replacement.
  - Adequate space for "in" and "out" water line connections.
  - Be near a drain for flushing and near a 110V outlet if the accessory (sold separately) Everguard Low Pressure Alarm is used. See Figures 1-6.

### OPERATING SPECIFICATIONS\*

| Combined Model Name                 | Replacement Cartridge | Flow Rate          | Capacity               |
|-------------------------------------|-----------------------|--------------------|------------------------|
| Coldrink System 1 - MC              | MC                    | 1.67 gpm (6.3 lpm) | 9,000 gal (34,000 L)   |
| Coldrink System 1 - MC <sup>2</sup> | MC <sup>2</sup>       | 1.67 gpm (6.3 lpm) | 9,000 gal (34,000 L)   |
| Coldrink System 1 - XC              | XC                    | 1.67 gpm (6.3 lpm) | 12,000 gal (45,420 L)  |
| Coldrink System 1 - XC <sup>2</sup> | XC <sup>2</sup>       | 1.67 gpm (6.3 lpm) | 12,000 gal (45,420 L)  |
| Coldrink System 1 - 4CB5            | 4CB5                  | 1.67 gpm (6.3 lpm) | 6,000 gal (22,710 L)   |
| Coldrink System 1 - 7CB5            | 7CB5                  | 2.5 gpm (9.4 lpm)  | 10,000 gal (37,850 L)  |
| Coldrink System 2 - MC              | MC                    | 3.3 gpm (12.6 lpm) | 18,000 gal (68,000 L)  |
| Coldrink System 2 - MC <sup>2</sup> | MC <sup>2</sup>       | 3.3 gpm (12.6 lpm) | 18,000 gal (68,000 L)  |
| Coldrink System 2 - XC              | XC                    | 3.3 gpm (12.6 lpm) | 24,000 gal (90,840 L)  |
| Coldrink System 2 - XC <sup>2</sup> | XC <sup>2</sup>       | 3.3 gpm (12.6 lpm) | 24,000 gal (90,840 L)  |
| Coldrink System 2 - 4CB5            | 4CB5                  | 3.3 gpm (12.6 lpm) | 12,000 gal (45,420 L)  |
| Coldrink System 2 - 7CB5            | 7CB5                  | 5.0 gpm (18.9 lpm) | 20,000 gal (75,700 L)  |
| Coldrink System 3 - MC              | MC                    | 5.0 gpm (18.9 lpm) | 27,000 gal (102,000 L) |
| Coldrink System 3 - MC <sup>2</sup> | MC <sup>2</sup>       | 5.0 gpm (18.9 lpm) | 27,000 gal (102,000 L) |
| Coldrink System 3 - XC              | XC                    | 5.0 gpm (18.9 lpm) | 36,000 gal (136,260 L) |
| Coldrink System 3 - XC <sup>2</sup> | XC <sup>2</sup>       | 5.0 gpm (18.9 lpm) | 36,000 gal (136,260 L) |
| Coldrink System 3 - 4CB5            | 4CB5                  | 5.0 gpm (18.9 lpm) | 18,000 gal (68,000 L)  |
| Coldrink System 3 - 7CB5            | 7CB5                  | 7.5 gpm (28.2 lpm) | 30,000 gal (113,550 L) |

\* For individual cartridge specifications, refer to cartridge literature.

Temperature: 35-100°F (2-38°C)

Pressure: 10-125 psi (0.7-8.6 bar), non-shock

For cold water use only.

### FLUSHING

For maximum life, all carbon filter cartridges must be flushed for five minutes at full flow before use.

**ALL NEW CARTRIDGES MUST BE FLUSHED AFTER EACH CARTRIDGE CHANGE BEFORE BEING PUT INTO SERVICE!**

If the cartridges are new, have been properly flushed and both needle and follower register inadequate pressure, or the LPA is sounding, you may be experiencing inadequate water pressure or some restriction may exist in the inlet water line. In either case, the incoming water pressure must be improved to receive optimum filter life.

COMPLETE CARTRIDGE CHANGE INSTRUCTIONS CAN BE FOUND ON THE FILTER CARTRIDGE LABEL.

**Not for residential use. For food service applications only.**



Figure 1 – Coldrink 1 System



Figure 2 – Coldrink 2 System



Figure 3 – Coldrink 3 System

## INSTALLATION

1. Use the predrilled mounting holes in the manifold bracket as guides. Mark and drill anchor holes. Mount securely. See Figures 4-6.
2. Shut off power to equipment.
3. Connect outlet port of Coldrink system to equipment served. Always use a NSF approved pipe dope or Teflon tape at all connections. Use a backup wrench on all fittings while connecting to avoid excessive stress on the system components.
4. Install a manual shut-off valve leading to the system for servicing.
5. Connect minimum 3/8" water line to the Coldrink 1 System inlet. Use a minimum 1/2" for Coldrink 2 and 3 Systems.
6. Connect tubing to flushing valve and run to drain. The cross fitting has a flushing valve installed on the bottom.

**Note:** Some municipal plumbing codes and good sanitary practices require an air gap at the drain termination point.

7. Shut off the system inlet valve located on the inlet of the prefilter head.
8. Check to be sure the O-ring on the prefilter housing is sufficiently lubricated. Use a good grade of silicone lubricant, if needed. Position the EC210 prefilter cartridge on guide seat in the bottom of the bowl. Then thread the bowl into the head by hand. Use a sump wrench to snug the bowl onto the head.
9. Install the carbon filter cartridge(s) into the filter head(s) following directions on the cartridge label or as shown in the Cartridge Change illustrations.
10. Turn on inlet water to the filter system and check for leaks.
11. Open the flushing valve and flush the cartridge(s) by running water through at full force for five minutes. This will set the filtering media and purge any air and fines, insuring maximum filter life. See illustrations.
12. After flushing, close the flushing valve, turn on power to equipment, and plug the LPA (if so equipped) into the electrical outlet. The system is ready for operation.

Check for compliance with state and local laws and regulations. Do not use with water that is microbiologically unsafe or of unknown quality without adequate disinfection before or after the system. Systems certified for cyst reduction may be used on disinfected waters that may contain filterable cysts.

**For installations in Massachusetts, the Commonwealth of Massachusetts Plumbing Code 248 CMR shall be adhered to. Consult your licensed plumber for installation of the system. This system and its installation must comply with state and local regulations.**

## CARTRIDGE CHANGE DETERMINATION

Replace the prefilter cartridge whenever it becomes excessively dirty (observed visually or by flow restriction). Follow the change instructions provided with the cartridge. Replace carbon filter cartridges when capacity is reached, or when flow becomes inadequate, but at least annually. All carbon filter cartridges on multiple cartridge systems should be changed at the same time. The system pressure gauge or accessory (sold separately) Everguard Low Pressure Alarm (LPA) provide quick, simple means of determining when the filter cartridge(s) should be checked. Installed on the system outlet manifold, the gauge or LPA can be used to monitor both dynamic (flowing) and static (line) pressure. The cartridge(s) should be changed when the pressure gauge needle is in the red area while equipment is in operation, and yet the needle shows adequate line pressure between cycles. Observe the needle during the next equipment on cycle. If the needle registers adequate pressure, it can be assumed that the temporary low-pressure condition was caused by a brief power failure or other incoming pressure disruption. If the low pressure condition is not due to an external condition, check/change the prefilter first. If the low pressure condition is still not corrected, change the carbon filter cartridges.

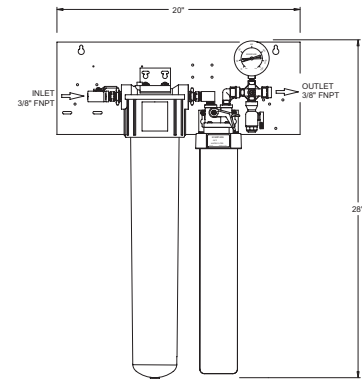

Figure 4 – Coldrink 1

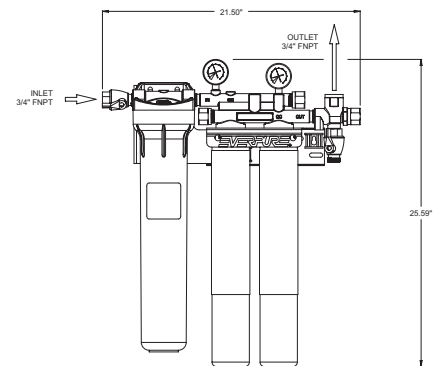

Figure 5 – Coldrink 2

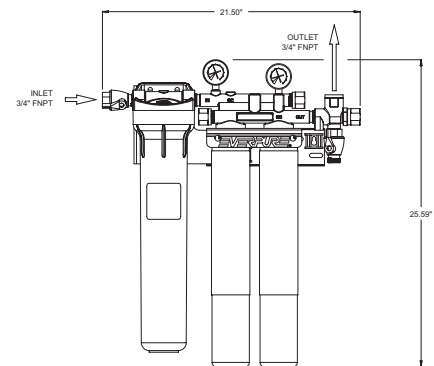

Figure 6 – Coldrink 3

## REPLACEMENT PARTS

Contact your local Everpure dealer for filter cartridges or system replacement parts.

| Description                                | Part Number |
|--|-------------|
| Outlet pressure gauge                      | EV3114-09   |
| Inlet pressure gauge<br>(Coldrink 2 and 3) | EV3114-09   |
| Inlet/flushing valve                       | EV3114-07   |
| O-ring for prefilter                       | EV3112-40   |
| Prefilter bowl                             | EV3112-38   |



System Tested and Certified by NSF International against NSF/ANSI Standards 42 and 53 for the reduction of:

Standard No. 42 —  
Aesthetic Effects  
*Chemical Reduction*  
Taste and Odor  
Chlorine

*Mechanical Filtration*  
Particulate Class 1: 99.2% reduction of particles one-half micron and larger in size (MC, MC<sup>2</sup>, XC, XC<sup>2</sup> only)

Standard No. 53 —  
Health Effects  
*Mechanical Filtration (MC, MC<sup>2</sup>, XC, XC<sup>2</sup> Only)*  
Turbidity  
Cyst  
Asbestos

## PRESSURE GAUGES

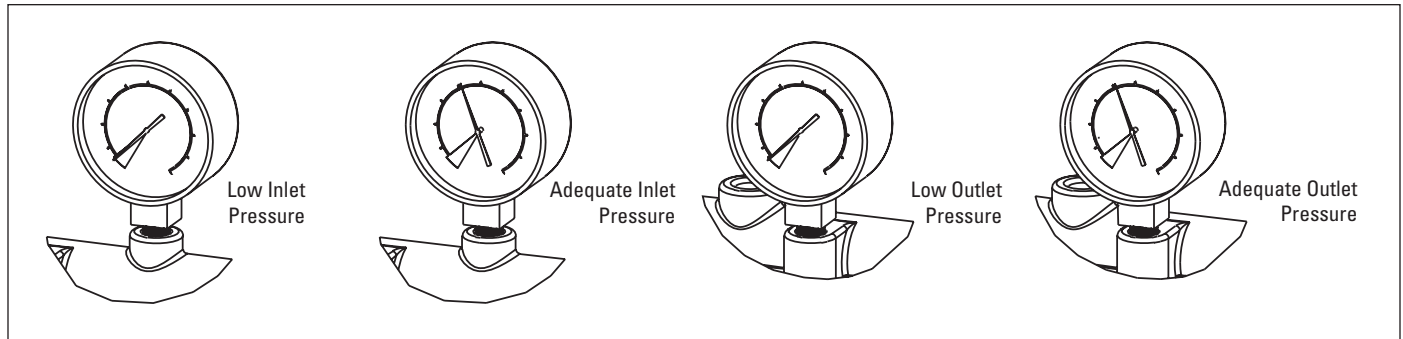

## CARTRIDGE CHANGE PROCEDURE

**E-Series Prefilter Cartridge Change**

1. Shut off power to equipment. Shut off inlet water ahead of system.

2. Push red relief valve. Unscrew bowl. Remove prefilter cartridge.

3. Clean bowl with filtered water only; NO SPECIAL CLEANERS.
4. Feel head o-ring. If dry, lubricate with high quality silicone lubricant.

5. Install new prefilter cartridge in bowl. Hand tighten bowl to head.

6. Turn on water. Turn on power to equipment.

**Everpure Carbon Filter Cartridge Change**

1. Shut off power to equipment. Shut off inlet water ahead of system.

2. Open flushing valve to relieve pressure.
3. Hold head firmly and push upward. Turn cartridge to left until it stops.

4. Pull cartridge downward and out of head.
5. Hold head firmly. Align cartridge lug with label. Insert new cartridge firmly into head.

6. Turn cartridge right 90° until rotation stops.
7. Repeat steps 3-6 for remaining cartridges.

**Flushing**

8. With flushing valve fully open, open inlet water at full force for five minutes. Close flushing valve.
9. Turn on power to equipment

# LIMITED WARRANTY

## COMMERCIAL WATER TREATMENT EQUIPMENT

You have just purchased one of the finest water treatment units made. As an expression of our confidence in Everpure products, this product is warranted against defects in material and workmanship to the original end-user when installed in accordance with Everpure specifications. The warranty period commences from the date of purchase and is administered as follows:

**For a period of ONE YEAR**

**Replaceable elements (i.e., filter & water treatment cartridges)\***

**For a period of FIVE YEARS**

**The entire system (excluding replaceable elements)**

**\*This is for material & workmanship, not filter or water treatment cartridge life.**

The unit must be used in operating conditions that conform to Everpure's recommended design guidelines. This warranty will not apply if the unit has been modified, repaired or altered by someone not authorized by Everpure.

**If a part described above is found defective within the specified period, you should notify Everpure technical service at the phone number listed below. Any part found defective within the terms of this warranty will be repaired or replaced (at Everpure's discretion) by your local dealer or Everpure technical service. You pay only freight from our factory and local dealer charges. Any repaired or replaced warranty item will be incorporated under the original warranty terms of the existing system.**

We are not responsible for damage caused by accident, fire, flood, freezing, Act of God, misuse, misapplication, neglect, oxidizing agents (such as chlorine, ozone, chloramines and other related components), alteration, installation or operation contrary to our printed instructions, or by the use of accessories or components which do not meet Everpure's specifications. Refer to the specifications section in the Installation and Operating manual for approved application parameters.

Our product performance specifications are furnished with each water treatment unit. TO THE EXTENT PERMITTED BY LAW, EVERPURE DISCLAIMS ALL IMPLIED WARRANTIES, INCLUDING WITHOUT LIMITATION WARRANTIES OF MERCHANTABILITY AND FITNESS FOR PARTICULAR PURPOSE; TO THE EXTENT REQUIRED BY LAW, ANY SUCH IMPLIED WARRANTIES ARE LIMITED IN DURATION TO THE PERIOD SPECIFIED ABOVE FOR THE ENTIRE WATER TREATMENT UNIT. As a manufacturer, we do not know the characteristics of your water supply or the purpose for which you are purchasing this product. The quality of water supplies may vary seasonally or over a period of time, and your water usage rate may vary as well. Water characteristics can also differ considerably if this product is moved to a new location. For these reasons, we assume no liability for the determination of the proper equipment necessary to meet your requirements, and we do not authorize others to assume such obligations for us. Further, we assume no liability and extend no warranties, express or implied, for the use of this product with a non-potable water source or a water source which does not meet the conditions for use described in the owner's guide or performance data sheet for this product. OUR OBLIGATIONS UNDER THIS WARRANTY ARE LIMITED TO THE REPAIR OR REPLACEMENT (AT EVERPURE'S DISCRETION) OF THE FAILED PARTS OF THE WATER TREATMENT UNIT, AND WE ASSUME NO LIABILITY WHATSOEVER FOR DIRECT, INDIRECT, INCIDENTAL, CONSEQUENTIAL, SPECIAL, GENERAL OR OTHER DAMAGES.

Some states do not allow the exclusion of implied warranties or limitations on how long an implied warranty lasts, so the above limitation may not apply to you. Similarly, some states do not allow the exclusion of incidental or consequential damages, so the above limitation or exclusion may not apply to you. This warranty gives you specific legal rights, and you may also have other rights which vary from state to state. Consult your telephone directory for your local independently operated Everpure dealer, or write Everpure for warranty and service information.



**For sales, replacement components, and service, contact your Everpure dealer or:**

**Everpure, LLC:** 1040 Muirfield Drive • Hanover Park, Illinois 60133 • 800.323.7873

**In Europe:** Toekomstlaan 30 • B-2200 Herentals, Belgium

**In Japan:** Hashimoto MN Bldg. 7F • 3-25-1 Hashimoto Sagamihara-Shi • Kanagawa 229-1103, Japan

**Technical Service**

800.942.1153

[www.everpure.com](http://www.everpure.com)