



EV9325-23

# Insurice Triple PF-i4000<sup>2</sup> System

Delivers premium quality water for ice applications



Insurice Triple PF-i4000<sup>2</sup> System: EV9325-23

i4000<sup>2</sup> Replacement Cartridge: EV9612-32

EC210 Prefilter Cartridge: EV9534-26

## BENEFITS

- Reduces ice machine problems caused by scale build-up from dirt and dissolved minerals (as tested by Everpure)
- New and improved Micro-Pure II media inhibits the growth of bacteria
- Reduces chlorine taste and odor and other offensive contaminants
- Self-contained scale inhibitor feed keeps ice machines functioning at full capacity (as tested by Everpure)
- Reduces maintenance and service costs by reducing scale\* and clogging of distribution lines, evaporator plate and pump (\*as tested by Everpure)
- Precoat submicron technology reduces dirt and particles as small as 1/2 micron in size and reduces health contaminants such as cysts
- 20" prefilter reduces dirt and particles
- Manifold features water shut off, flushing valve and outlet pressure gauge
- Sanitary cartridge replacement is simple, quick and clean. Internal filter parts are never exposed to handling or contamination
- NSF Certified under NSF/ANSI Standards 42 & 53

## INSTALLATION TIPS

- Choose a mounting location suitable to support the full weight of the system when operating
- Never use saddle valve for connection
- Use 3/4" water line
- Do not connect system to water-cooled condenser
- Install vertically with cartridges hanging down and allow 2-1/2" clearance below the cartridge for easy cartridge replacement
- Flush cartridges by running water through system for five minutes at full flow

## OPERATION TIPS

- Change cartridges on a regular 6 month preventative maintenance program
- Change cartridges when capacity is reached or when pressure falls below 10 psi
- Service flow rate must not exceed 5.0 gpm
- Always flush the filter cartridge at time of installation and cartridge change
- Inspect EC210 cartridge periodically to determine dirt load
- Replace EC210 cartridge when dirt has penetrated through to the inner core of the cartridge

## APPLICATION/SIZING

- For ice machine applications
- Higher volume, higher flow and higher capacity ice machines
- Rated Capacity: 36,000 gallons

# Insurice Triple PF-i4000<sup>2</sup> System

## SPECIFICATIONS

### Overall Dimensions:

29.59"H x 25.75"W x 6"D

Inlet connection: 3/4"

Outlet connection: 3/4"

### Service Flow Rate:

Maximum 5.0 gpm (18.9 Lpm)

Rated Capacity: 36,000 gallons

### Pressure Requirements:

10 - 125 psi (0.7 - 8.6 bar), non-shock

Temperature: 35 - 100°F (2 - 38°C)

No electrical connection required

Shipping Weight: 23 lbs.

Operating Weight: 35 lbs.

The contaminants or other substances removed or reduced by this drinking water system are not necessarily in your water. Do not use with water that is microbiologically unsafe or of unknown quality without adequate disinfection before or after the system. Systems certified for cyst reduction may be used with disinfected water that may contain filterable cysts.

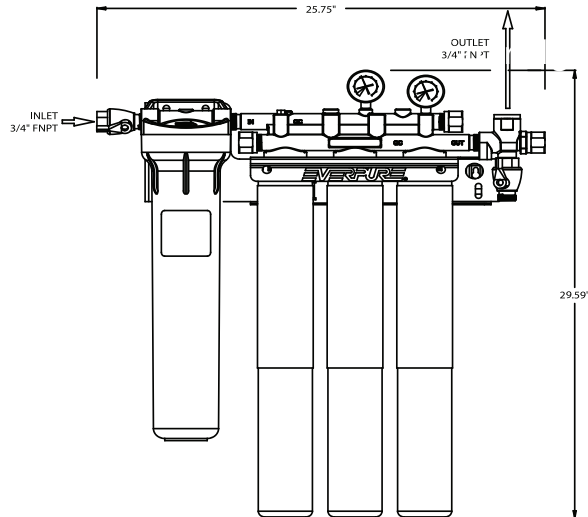

## WARRANTY

Everpure water treatment systems (excluding replaceable elements) are covered by a limited warranty against defects in material and workmanship for a period of five years after date of purchase. Everpure replaceable elements (filter cartridges and water treatment cartridges) are covered by a limited warranty against defects in material and workmanship for a period of one year after date of purchase. See printed warranty for details. Everpure will provide a copy of the warranty upon request.



System Tested and Certified by NSF International against ANSI/NSF Standard 42 and 53 for the reduction of:

Standard No. 42: Aesthetic Effects  
Chemical Unit

Taste and Odor Reduction

Chlorine Reduction, Class I

Mechanical Filtration Unit

Nominal Particulate Reduction,

Class I:

97.9+% reduction of particles  
one-half micron and larger in size

Standard No. 53: Health Effects

Mechanical Filtration Unit

Cyst Reduction

## EVERPURE®

### Worldwide Headquarters:

EVERPURE, LLC  
1040 Muirfield Drive  
Hanover Park, Illinois 60133  
Toll Free (800) 323-7873  
Tel (630) 307-3000  
Fax (630) 307-3030  
<http://www.everpure.com>

### In Europe:

Pentair Water Belgium B.V./B.A.  
Industriepark Wolfstee  
Toekomstlaan 30  
B- 2200 Herentals  
BELGIUM  
TEL: +32.(0).14.283.500  
FAX: +32.(0).14.283.505

### In Japan:

Hashimoto MN Bldg. 7F  
3-25-1 Hashimoto Sagamihara-Shi  
Kanagawa 229-1103  
JAPAN  
TEL: 81.(0)42.775.3011  
FAX: 81.(0)42.775.3015